

# Differential Geometry in Toposes

Ryszard Paweł Kostecki

*Institute of Theoretical Physics, University of Warsaw  
Hoża 69, 00-681 Warszawa, Poland*

email: ryszard.kostecki % fuw.edu.pl

December 27, 2009

## Abstract

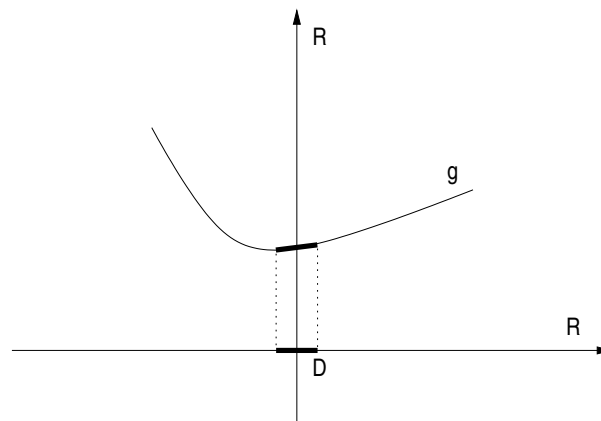

## Contents

<b>1</b>	<b>Introduction</b>	<b>2</b>
1.1	Ancient Greek approach . . . . .	2
1.2	Modern European approach . . . . .	3
1.3	Beyond modern approach . . . . .	4
1.4	From infinitesimals to microlinear spaces . . . . .	5
1.5	The zoology of infinitesimals . . . . .	9
1.6	Algebraic geometry and schemes . . . . .	12
1.7	Algebraic differential geometry and toposes . . . . .	14
1.8	Well-adapted topos models of infinitesimal analysis and geometry . . . . .	15
<b>2</b>	<b>From Kock–Lawvere axiom to microlinear spaces</b>	<b>20</b>
<b>3</b>	<b>Vector bundles</b>	<b>27</b>
<b>4</b>	<b>Connections</b>	<b>34</b>
<b>5</b>	<b>Affine space</b>	<b>45</b>
<b>6</b>	<b>Differential forms</b>	<b>51</b>
<b>7</b>	<b>Axiomatic structure of the real line</b>	<b>59</b>
<b>8</b>	<b>Coordinates and formal manifolds</b>	<b>66</b>
<b>9</b>	<b>Riemannian structure</b>	<b>75</b>
<b>10</b>	<b>Some additional structures</b>	<b>77</b>
<b>11</b>	<b>Well-adapted topos models</b>	<b>79</b>
	<b>References</b>	<b>86</b>
	<b>Index</b>	<b>92</b>

# 1 Introduction

## 1.1 Ancient Greek approach

Ancient Greek mathematics was deeply influenced by Pythagorean description of quantity exclusively in terms of geometry, considering quantities as *defined* by the proportions of lengths, areas and volumes between certain geometrical constructions. However, it soon became clear that there are also such geometrical objects which are nonquantitative in this sense – the diagonals of several squares appeared to have irrational lengths. The problem of difference between continuity of qualitative changes and discreteness of quantity has shown up for the first time. Probably the most important attempt of presocratic philosophy to solve this problem was the atomistic philosophy of Abderian school of Leucippus and Democritus. In some relation to the Pythagorean notion of *monad*, they have developed the theory of *atoms*, the infinitesimally small objects which were in neverending motion, forming the geometrical (as well as *physical*) structures and their properties. This theory intended to provide some kind of finitary arithmetical method (of countable but infinitesimal atoms) in order to describe continuity and movement in quantitative terms. However, the theory of infinitesimals was shown to be logically inconsistent by the famous paradoxes of Zeno. These paradoxes have deeply influenced the postsocratic philosophy of ancient Greece (Zeno and Socrates have lived at approximately the same time), leading to elimination of the actual change (dynamics) from the Aristotelian physics and to consideration of *only finite* proportions between geometrical figures (as well as finite procedures of construction) in the mathematics of Eudoxos and Euclid. Aristotle denied infinitesimals, and denied also the possibility that numbers can compose into continuum, because they are divisible [Aristotle:Metaph]. He has argued that *a line cannot consist of points* and *a time cannot consist of moments*, because *a line is continuous, while a point is indivisible, and continuous is this, what is divisible on parts which are infinitely divisible*.<sup>1</sup> This has lead him to the denial of the idea of actual velocity (that is, the velocity in a given point): *nothing can be in the movement in the present moment (...)* and *nothing can be in the rest in the present moment* and to regarding the idea of *actual infinity* as non-empirical and logically inconsistent [Aristotle:Physics]. Hence, the only possible kind of the change and appearance of the infinity was the potential one (note that the word *potentiality* is a latin translation of the Greek word *dynamis*). In effect, the physical change and movement is described by Aristotle as a result of transition from potential *dynamis* to actual *entelechia* (that is, from continuous potentiality to the discrete act). The measurable properties are considered by Aristotle to be always the actual ones, and that is why the *measurable* part of his physics refers only to static properties. Nevertheless, from the Aristotelian point of view any real object (*ousia*) consists from both: potential dynamical matter (*hyle*) and actual static form (*morphe*).

The Aristotelian description of dynamics is only qualitative, due to impossibility of quantitative approach to continuum forced by Zeno paradoxes. These paradoxes forced the shape of all postsocratic mathematics, which had also denied the possibility of using infinitesimals. In order to describe quantitative aspects of qualitative (geometrical) objects, such as area of the circle, Eudoxos had developed the *finitary* method of exhausting (later brilliantly applied by Archimedes), which enabled to obtain values of fields and volumes of the geometrical figures up to any given precision. From the modern point of view, this method can be thought of as finitary algorithm of approaching irrational numbers, however one should remember that ancient Greeks have not considered irrationals as numbers.<sup>2</sup> The notion of a number (quantity) was reserved

<sup>1</sup>Note that this reasoning uses implicitly the law of excluded middle (formulated by Aristotle in form *it is impossible to simultaneously claim and deny* [Aristotle:SecAn]) through saying that points cannot be divisible and indivisible.

<sup>2</sup>In Plato's Academia there was known also second finitary method of approaching the irrationals, developed

exclusively to proportions (rational numbers). As a result of this identification, and due to the logical inconsistency of infinitesimal methods shown in Zeno paradoxes, the ancient logically consistent solution of the problems of change in time and description of quality (geometry) in quantitative (arithmetical) terms had to be provided by elimination of the measurable dynamics from physics and elimination of the infinitary arithmetical methods from mathematics.

## 1.2 Modern European approach

The reconciliation of the problem of relation between quantity and qualitative change in modern Europe has led to formulation of analytic geometry by Descartes and of differential and integral calculus by Newton and Leibniz. In these times (XVIIth century) the ancient interpretation of quantity as geometrical proportion was still widespread, and it was replaced by Cartesian interpretation of quantity as function only in XVIIIth century. It is worth to note, that both Newton and Leibniz denied to interpret the calculus in purely arithmetical or geometrical terms. Newton's viewpoint on the foundations of calculus has drifted, starting from consideration of the infinitesimally small objects which are neither finite, nor equal to zero [Newton:1669], through the finite limits of "last proportions" between these objects [Newton:1676], ending on consideration of constant velocity encoded in the notion of fluxions [Newton:1671]. As notes Boyer [Boyer], Newton preferred the idea of continuity of change, so, in order to preserve the direct physical meaning of the mathematical methods, he was avoiding the arithmetical notion of a limit (contrary to his teacher, Wallis) and tended to formulation based on differential rather than on infinitesimals. On the other hand, Leibniz was clearly stating that the fundamental object of calculus are infinitesimals, understood as mathematical representatives of the philosophical idea of monad. He treated infinitesimals as objects which existed mathematically, however were not expressible arithmetically, despite the fact that their proportions were quantitative. In his opinion, infinitesimals are *not equal to zero* but *such small, that incomparable and such that the appearing error is smaller than any freely given value* and deprived of existence as *actual quantity: I do not believe that there exist infinite or really infinitely small quantities* [Boyer]. So, while Newton has considered the "moment" of continuous change as physically real, Leibniz denied the physical reality of infinitesimals. These opinions of Newton and Leibniz had led to logical confusion in the next century. Berkeley has shown that the Newtonian idea of actual velocity has no consistent physical sense [Berkeley], while D'Alembert has denied Leibnizian infinitesimals as logically inconsistent: *any quantity is something or not; if it is something, it does not disappear; if it is nothing, it disappears literally. (...) A presumption that there exists any state between those two is a daydream.* [Boyer]. Hence, one more time in history, infinitesimals were regarded as unacceptable due to the *tertium non datur* principle. The serious research in the foundations of analysis has developed only after the works of Euler, who had extended and popularized Cartesian understanding of quantity in terms of function and had also provided the serious arithmetization of analysis. The crucial step was done by Cauchy, who denied infinitesimals and, following Lhuilier, regarded the differential defined through infinitesimal limit as fundamental notion of analysis. His definition of differentiation has denied the geometrical description in favor to arithmetical one, based on functions and variables. This was similar to the approach of Bolzano, who had moreover regarded the continuum as consisting of discrete points. However, the description performed by Cauchy still had a dynamical sense of variables and functions "approaching" the limit. The final foundational step was performed in the second part of the XIXth century by Weierstrass, who had eliminated from analysis any elements of dynamics, geometry and continuous movement, by reducing it totally to arithmetical and order-

---

by Theatetus and called *anthyphareis*. And while Eudoxos' exhausting can be considered as ancient analogue of Dedekind cuts, Theatetus' anthyphareis can be considered as ancient analogue of modern method of continued fractions, which was later absorbed in Cauchy definition of real numbers.

ing considerations. The Weierstrassian definition of a limit of sequence, based on identification of the sequence with its limit, denies the intuition of “approaching”. Hence, although the notation  $f'(t) = \frac{df}{dt}$  is widely used, from the Weierstrassian perspective the differential *cannot* be thought of as a small amount of curve  $f$  divided by a small amount of time  $t$ . By these means, the geometrical continuum has been regarded as purely arithmetical construction. However, in order to obtain full logical consistency, the definition of limit had to be stated independently from the definition of irrational numbers. This could be performed only in the framework of Cantor’s set theory, which provided tools for handling the “trancendent” area of infinite sets. Cantor’s set theory was based on arbitrary abstraction of *actual infinity*, which is grounded in the axiom of excluded middle. This abstraction enables to identify in(de)finitely prolongable constructions with their nonconstructible ‘results’, treating the latter as full fledged mathematical objects. This way Cantor’s abstraction served as foundation for Weierstrassian interpretation of analysis. However, it soon has been shown that this theory is plagued by several paradoxes (like Russell paradox). Two main solutions of this problem were provided by Zermelo–Fraenkel [ZermeloFraenkel] set theory and Russell–Whitehead [RW:PM] type theory. Both these theories provided a consistent framework for Weierstrassian arithmetical foundations for analysis, free from any geometrical and dynamical notions in favor to static, infinitary and order-theoretic ones. Both ZF and RW systems contain two axioms which are crucial for the formulation of analysis in terms of Weierstrass: the axiom of choice and the axiom of infinity (in [RW:PM] the analogues of these axioms are called MultAx and AxInf, respectively). The first axiom is equivalent to continuum hypothesis which states that Cantorian  $\aleph_1$  is equivalent with *the continuum* of analysis and geometry, while the second one is an assumption about possibility to have countable but infinite sets (producing the set  $\{\emptyset, \{\emptyset\}, \{\emptyset, \{\emptyset\}\}, \dots\}$ ). These axioms are independent from the rest of the system,<sup>3</sup> hence they represent the arbitrary assumptions about the nature of continuum. The axiom of choice depends on the law of excluded middle, so it reflects also certain logical assumption. Together they represent Cantor’s abstraction of actual infinity.

An important byproduct of the Cauchy–Weierstrass line of interpretation was denial of the definition of integration as a process which is dual to differentiation. It was caused by the discovery (by Bolzano and Weierstrass) of the examples of non-continuous but integrable functions. In effect, the theory of integration, developed by Riemann, Lebesgue, Stieltjes, Radon and Nikodym became independent from the theory of differentiation.

One can conclude that the *interpretation* of the Newton–Leibniz geometric and dynamic analysis provided in purely static and order-theoretic arithmetical terms on grounds of set or type theory is possible due to assumption of existence of infinitely many individual elements in set, validity of the law of excluded middle, and an abstraction of actual infinity. This is the modern logically consistent mathematical solution of the Zeno paradoxes an the problem of relation between continuity and quantity.

### 1.3 Beyond modern approach

The arbitrary and idealistic character of the axiom of choice and abstraction of actual infinity was criticized by Kronecker and Poincare as weak elements of Weierstrassian formulation of analysis. However, it was Brouwer who had explicitly presented a concrete opposition and alternative to it. He had denied the possibility of application of axiom of choice with respect to infinite sets, especially in the form of abstraction of actual infinity. In his opinion, the proof of existence of a certain mathematical object (proposition) must be given by the explicit construction, and

<sup>3</sup>In particular, the continuum hypothesis (C) was shown by Cohen to be independent from the other constituents of the Zermelo–Fraenkel set theory.

not by indirect reasoning based on idealistic assumptions. Brouwer called such mathematics intuitionistic or constructive. By definition, it was free of paradoxes. Heyting developed an algebra which has modelled the intuitionistic logic of Brouwer, denying the need of the law of excluded middle, and directly generalizing Boolean algebra (which is an algebraic model of an axiomatic system of classical logic). This was possible due to independence of the axiom of excluded middle from the rest of Boolean logic, what is in precise analogy with the independence of continuum hypothesis (C) from the rest of ZF system. The intuitionistic Brouwer–Heyting logic disregards the axiom of excluded middle in the same way as non-Euclidean geometry disregards fifth postulate of Euclid. In both cases the denial of the additional independent axiom leads to great development of more general mathematical structures, however, it requires stronger proofs. [Tarski–Stone representation]

The development of model theory by Tarski and others has lead to possibility of consideration of different models of analysis based on ZF(C) set theory. In particular, Robinson has developed non-standard analysis, which gave consistent meaning to *invertible* infinitesimals, as well as infinitely large numbers. [NSA]

[Forcing, Cohen, Kripke semantics]

[Type theory, intuitionistic type theory]

At the same time the geometers Weil, Eilenberg and Grothendieck have laid the foundations for completely algebraic theory of *nilpotent* infinitesimals. Their intention was to formalize, at least partially, the completely geometric (as opposed to arithmetic) intuition of infinitesimals, present in the works of Riemann and Lie. This new algebraic approach became possible due to Kähler’s definition of a tangent bundle of space  $M$  as a ring  $C^\infty(M)$  of smooth functions on  $M$  divided by an ideal  $m^2$  of functions which square is equal to zero, and definition of a cotangent bundle as a ring  $m/m^2$ , where  $m$  is an ideal of functions equal to zero. First order nilpotent infinitesimals are just the elements of ideal  $m^2$ , and  $k$ -th order nilpotent infinitesimals are the elements of  $m^{k+1}$ . Such definition enabled to use nilpotents and differentials in algebraic geometry, which is not equipped with smooth background, but deals very well with rings and ideals.

## 1.4 From infinitesimals to microlinear spaces

The infinitesimal analysis (and differential geometry) can be developed as an algebraic system based on an assumption that the structure of the real line may be modeled by such commutative unital ring  $R$ , that there exists the object of nilpotent infinitesimals

$$D := \{x \in R \mid x^2 = 0\} \subset R, \quad (1)$$

and  $D \neq \{0\}$ . This implies that  $R$  cannot be considered to be equal to the set-theoretic field  $\mathbb{R}$ . Condition  $D \neq \{0\}$  forces the existence of some *infinitesimal*  $x \in R$  that is not equal to zero, but is ‘such small’ that  $x^2 = 0$ . The *Kock–Lawvere axiom*

$$\forall g : D \rightarrow R \ \exists ! b : D \rightarrow R \ \forall d \in D \quad g(d) = g(0) + d \cdot b \quad (2)$$

imposed on the structure of this ring says that every function on  $R$  is differentiable. On the plane  $R \times R$  this axiom means that the graph of  $g$  coincides on  $D$  with a straight line with the slope  $g'(0) := b$  going through  $(0, g(0))$ ,

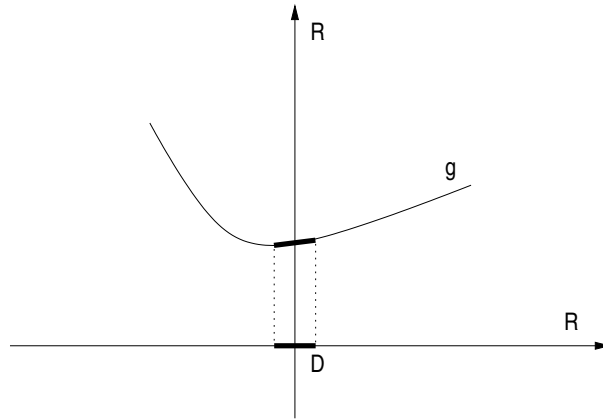

where the line tangent to  $g$  at  $0$  is tangent on an infinitesimal part of domain  $D \subset R$  (and *not* in the sense of a limit in a point!). This implies that every function is infinitesimally linear. However, the Kock–Lawvere axiom is not compatible with the law of excluded middle. Let’s define a function  $g : D \rightarrow R$  such that

$$\begin{cases} g(d) = 1 & \text{iff } d \neq 0, \\ g(d) = 0 & \text{iff } d = 0. \end{cases} \quad (3)$$

The Kock–Lawvere axiom implies that  $D \neq \{0\}$ , because otherwise  $b$  would be not unique. So (using the law of excluded middle) we may assume that there exists such  $d_0 \in D$  that  $d_0 \neq 0$ . From the Kock–Lawvere axiom we have immediately  $1 = g(d_0) = 0 + d_0 \cdot b$ . After squaring both sides we receive  $1 = 0$ .

This result means that we cannot make anything meaningful based on Kock–Lawvere axiom using the classical logic in which the law of excluded middle holds. However, we are not restricted to such logic, and we can use the weaker logic which does not use this law. After the substraction of this law from the set of axioms of classical logic, we obtain the set of axioms of intuitionistic logic. The usage of the latter is very similar to the usage of classical logic. The only difference is the need of performing all proofs in the constructive way, without assuming the existence of objects which cannot be explicitly constructed, hence without the axiom of choice. Of course, the post-Weierstrassian set-theoretic line  $\mathbb{R}$  is not a good model of  $R$ . However, we will show later that there are good models of  $R$  which reexpress all constructive contents of post-Weierstrassian analysis.

We call a property  $P$  of an object  $A$  *decidable* if  $\vdash (P(x) \vee \neg P(x))$  for every  $x \in A$  (the  $\vdash$  sign reads as ‘is satisfied’). The Kock–Lawvere axiom implies that equality in  $R$  is not decidable:

$$\exists x, y \in R \quad \not\vdash (x = y) \vee (x \neq y) \quad (4)$$

(we will see later that  $R$  is not decidable not only for the property of equality of elements, but also for other properties, such as the ordering). Clearly, this non-decidability is introduced by the subobject  $D$  of the infinitesimal elements. The non-decidability of infinitesimal objects can be interpreted as their ‘non-observability’ (in the Boolean frames)<sup>4</sup>. Infinitesimals appear then with a perfect agreement with Leibniz’ idea of “auxiliary variables” [Fearn:2002]. But this leads to an important conclusion: we cannot think about the real line  $R$  as consisting of equally ‘observable’ points laying infinitesimally close to each other (also because so far we have not defined any ordering structure). Only *some* elements of space are measurable and decidable,

<sup>4</sup>We will show below that the non-observability of infinitesimals is strenghtened by the generalized Kock–Lawvere axiom and the way of construction of the microlinear (differentiable) spaces.

and only these elements can be “pointed” while one considers some kind of movement (this is very important issue for dissolving Zeno paradoxes). This means also that the differentiability and smoothness of functions and curves on  $R$  actually relies on ‘unobservable’ elements of  $R$ .

To enhance differentiability to any order of Taylor series, we have to consider also an object

$$D_n := \{x \in R \mid x^{n+1} = 0\} \subset R. \quad (5)$$

It would be good if sums and multiplications of infinitesimals would be infinitesimal too. However,  $D$  is not an ideal of  $R$  (e.g.  $(d_1 + d_2)^2 = 2d_1d_2 \neq 0$ ). Hence, in order to hold infinitesimality, we have to consider more wide class of infinitesimal objects, such that appropriate polynomials of infinitesimal elements are forced to cease. These are so-called *spaces of formal infinitesimals* (called also *nilpotent objects*, *infinitesimal affine schemes*, or just *infinitesimal spaces*), defined as spectra of Weil algebras,

$$D(W) := \text{Spec}_R(W) = \{(d_1, \dots, d_n) \in R^n \mid p_1(d_1, \dots, d_n) = \dots = p_m(d_1, \dots, d_n) = 0\}, \quad (6)$$

where  $W$  is a Weil  $R$ -algebra with a finite presentation in terms of an  $R$ -algebra with  $n$  generators divided by the ideal generated by the polynomials  $p_1, \dots, p_m$ :

$$R[X_1, \dots, X_n] / (p_1(X_1, \dots, X_n), \dots, p_m(X_1, \dots, X_n)).$$

For example, one can consider

$$D := \text{Spec}_R(R[X]/(X^2)) = \{d \in R \mid d^2 = 0\},$$

$$\text{Spec}_R(R[X, Y]/(X^2 + Y^2 - 1)) = \{(x, y) \in R^2 \mid x^2 + y^2 - 1 = 0\}.$$

The structure  $R[X]/(X^2)$  appears very naturally if one defines the multiplication in  $R \times R$  by the rule  $(a_1, b_1)(a_2, b_2) := (a_1a_2, a_1b_2 + a_2b_1)$ . In such case the Kock-Lawvere axiom (2) can be stated as requirement that the map  $\alpha : R[X]/(X^2) \rightarrow R^D$  such that  $\alpha : (a, b) \mapsto [d \mapsto a + db]$  should be an isomorphism. Noticing that  $D = \text{Spec}_R(R[X]/(X^2))$ , one can use the formal infinitesimals for the generalization of the Kock-Lawvere axiom into form: *For any Weil algebra  $W$  the  $R$ -algebra homomorphism  $\alpha : W \rightarrow R^{D(W)}$  is an isomorphism.* This generalization allows to solve the problem that the result of addition or multiplication of infinitesimals is not an infinitesimal, equivalent with the fact that (formal) infinitesimals do not form an ideal of  $R$ . Consider the addition  $d_1 + d_2$  and the multiplication  $d_1 \cdot d_2$ . They can be formulated in categorical terms as commutative diagrams

$$D \times D \begin{array}{c} \xrightarrow{id} \\ \xrightarrow[r]{\cong} \end{array} D \times D \xrightarrow{+} D_2 \quad (7)$$

and

$$D \times D \begin{array}{c} \xrightarrow{id} \\ \xrightarrow[r]{\cong} \end{array} D \times D \xrightarrow{\cdot} D, \quad (8)$$

where  $r(d_1, d_2) = (d_2, d_1)$ . We can say, that functions ‘perceive’ the multiplication and addition of infinitesimal as surjective, if the diagrams

$$R^{D \times D} \begin{array}{c} \xleftarrow{R^r} \\ \xleftarrow[R^{id}]{\cong} \end{array} R^{D \times D} \xleftarrow{R^+} R^{D_2} \quad (9)$$

and

$$R^{D \times D} \begin{array}{c} \xleftarrow{R^r} \\ \xleftarrow[R^{id}]{\cong} \end{array} R^{D \times D} \xleftarrow{R} R^D \quad (10)$$

are commuting equalizer diagrams. However, this is true thanks to the generalized Kock-Lawvere axiom and the fact that the diagrams of Weil algebras which generate (7) and (8) are commuting equalizer limit diagrams. So, despite (7) and (8) are not coequalizer diagrams, they are

‘perceived’ to be such by all functions on  $R$ . This is a basic example of an operation on infinitesimals which is ‘thought to be surjective’ by functions on  $R$ . Another operations are given by another *limit* diagrams of Weil algebras. In general, the generalized Kock-Lawvere axiom forces that functions which work on infinitesimals ‘perceive’ their multiplication, addition and other operations as surjective, because it establishes that for the limit diagrams of Weil algebras

$$\begin{array}{ccc} & \text{Lim } W & \\ \mu_i \swarrow & & \searrow \mu_j \\ W_i & \xrightarrow{f} & W_j, \end{array} \quad (11)$$

the diagram

$$\begin{array}{ccc} & R^{D(\text{Lim } W)} & \\ R^{D(\mu_i)} \swarrow & & \searrow R^{D(\mu_j)} \\ R^{D(W_i)} & \xrightarrow{R^{D(f)}} & R^{D(W_j)}, \end{array} \quad (12)$$

is also a limit, despite that the diagram

$$\begin{array}{ccc} & D(\text{Lim } W) & \\ D(\mu_i) \swarrow & & \searrow D(\mu_j) \\ D(W_i) & \xleftarrow{D(f)} & D(W_j). \end{array} \quad (13)$$

is *not* a colimit. Here we symbolically write  $f : W_i \rightarrow W_j$  to denote any diagram which can be a base for some limit cone of Weil algebras  $\{W_i\}_{i \in I}$ , with  $\text{Lim } W$  given by projective limit  $\lim_{\leftarrow i \in I} W_i$ . This way all algebra of infinitesimal elements works ‘invisible’ (and ‘unobservable’!) from the point of view of ordinary functions, which are differentiable thanks to these infinitesimals. In such case  $R$  is called to ‘perceive (64) as colimit’, and (64) is called a quasi-colimit. The procedure of proving that concrete quasi-colimit diagrams of formal infinitesimal objects are perceived as colimits is a basic type of proof in infinitesimal geometry, and it plays here the same role as the procedure of proving that the higher-order terms in standard differential geometry are becoming negligible. However, in the case of infinitesimal geometry all operations are performed purely geometrically and categorically, without any consideration of the infinitesimal limit (in an analytic sense) or a system of local coordinates.

We can consider now the formal infinitesimals  $D(W)$  as an image of the covariant functor  $D = \text{Spec}_R$  from the category  $\mathcal{W}$  of Weil finitely generated  $R$ -algebras to the cartesian closed category  $\mathcal{E}$  of intuitionistic sets, which contains models of such objects like  $R$ ,  $D(W)$ , etc. Moreover, we have the functor  $R^{(-)} : \mathcal{E} \rightarrow \mathcal{E}$ . The generalized Kock–Lawvere axiom says that the covariant composition of functors

$$\mathcal{W} \xrightarrow{\text{Spec}_R} \mathcal{E} \xrightarrow{R^{(-)}} \mathcal{E}$$

sends limit diagrams in  $\mathcal{W}$  to limit diagrams in  $\mathcal{E}$ . This axiom allows to define the notion of infinitesimally differentiable (microlinear) manifold, without use of topology or coordinates. Let  $\mathcal{D}$  be a finite inverse diagram (cocone) of infinitesimal spaces which is an image of a functor  $D = \text{Spec}_R$  applied to some finite diagram in the category of Weil algebras, and is send by  $R^{(-)}$  to a limit diagram in a cartesian closed category  $\mathcal{E}$ . An object  $M$  of  $\mathcal{E}$  is called the *microlinear space* if the functor  $M^{(-)}$  sends every  $\mathcal{D}$  in  $\mathcal{E}$  into a limit diagram. In such case  $M$  is said to *perceive*  $\mathcal{D}$  as a colimit diagram, and  $\mathcal{D}$  is called a *quasi-colimit*. Hence, if  $M$  is a microlinear space and  $X$  is any object, then  $M^X$  is microlinear. Any finite limit of microlinear objects



is microlinear.  $R$  and its finite limits as well as its exponentials are microlinear. And any infinitesimal space is microlinear too.

The notion of microlinear space encodes the full *differential* content of the post-Weierstrassian notion of ‘differential manifold’. It clearly needs no topology, neither the local covering and coordinates, in order to construct and handle the differential geometric objects. Later we will see how one can add topological structure to microlinear spaces (what will result in the definition of a *formal manifold*). This separation of topological and arithmetical constructions from algebraic, geometric and differential ones is the key and striking achievement of infinitesimal analysis.

## 1.5 The zoology of infinitesimals

Consider now a problem of definition of a tangent bundle of a differential manifold. The common definition of a tangent space (fiber of tangent bundle) at some point  $p \in M$  is based on consideration of equivalence class of functions on this manifold which have equal their Taylor expansion term up to order 1:

$$f \sim g \iff f(p) = g(p) \wedge \frac{\partial f_i}{\partial x_j}(p) = \frac{\partial g_i}{\partial x_j}(p).$$

This definition can be shown to be independent on topology of the manifold. Such equivalence class of smooth (infinitely differentiable) functions is called a 1-jet at  $p$ . For example, the 1-jet of a function  $f(x, y)$  at  $p$  is specified by the set

$$\left\{ f(p), \frac{\partial f}{\partial x}(p), \frac{\partial f}{\partial y}(p) \right\}.$$

One can define naturally  $k$ -jets by condition of equality on higher terms of Taylor expansion, up to  $k$ . In order to algebraically handle the notion of element of  $k$ -jet of  $n$ -dimensional manifold  $M$ , one can consider an infinitesimal object  $D_k(n)$  defined as

$$D_k(n) := \{(x_1, \dots, x_n) \in R^n \mid x_{i_1} \cdot \dots \cdot x_{i_{k+1}} = 0 \text{ for any } k\text{-tuple } (i_1, \dots, i_{k+1})\}.$$

Clearly,  $D_k = D_k(1)$  and  $D = D_1(1)$ .  $D_k(n)$  is a representing object of the notion of  $k$ -jet in  $n$  variables  $j^k$ , i.e.  $j^k$  is equivalent to map  $D_k(n) \rightarrow R$ . The space  $J^k$  of all  $k$ -jets  $j^k$  of  $R$ , defined by

$$f, g \in J_p^k \iff f(p) = g(p) \wedge \frac{\partial f_i}{\partial x_j}(p) = \frac{\partial g_i}{\partial x_j}(p) \wedge \dots \wedge \frac{\partial^{(n)} f_i}{\partial x_{j_1} \dots \partial x_{j_n}}(p) = \frac{\partial^{(n)} g_i}{\partial x_{j_1} \dots \partial x_{j_n}}(p),$$

is equal to the space  $R^{D_k(n)}$ .  $D_k(n)$  are contained in duals  $D(W)$  of all Weil algebras. The latter represent the generalized jet bundles. This means that the generalized Kock–Lawvere axiom states that *every jet is representable*.

$$D_\infty^n = \{x \in R^n \mid \exists k \in N \ x^k = 0\} = \mathfrak{m}_k D_k(n)$$

$D(W)$  is a subobject of two bigger infinitesimal objects:

$$\Delta := \{x \in R \mid \neg(x \in \text{Inv } R)\} = \{x \in R \mid \neg \neg x = 0\}$$

and

$$\triangle := \mathfrak{U}_{n>0} \left( -\frac{1}{n}, \frac{1}{n} \right) = \{x \in R \mid \neg(x \neq 0)\},$$

where the *apartness relation*  $\#$  and the *object of invertible elements*  $\text{Inv } R$  are defined as:

$$x\#y := \exists n \in \mathbb{N} \quad -\frac{1}{n} < x - y < \frac{1}{n}$$

$$\text{Inv } R := \{x \in R \mid \exists y \in R \quad xy = 1\}.$$

All these type of infinitesimals form a following sequence of subobjects:

$$D(n) \subset D^n \subset D_k(n) \subset D_k^n \subset D(W) \subset \Delta^n \subset \mathbb{A}^n.$$

$\mathbb{A}$  is an ideal of  $R$ , what implies that one can distinguish physical (measurable) elements of  $R$  from nonphysical ones in terms of the apartness relation, which ‘cuts off’ all arithmetic of infinitesimals. In all models which contain (are capable to model) only the nilpotent infinitesimals, the equation  $\Delta = \mathbb{A}$  is satisfied. However, there are also some models in which one can consider also the object  $\mathbb{I}$  of *invertible infinitesimals*:

$$\mathbb{I} := \{x \in R \mid x \in \mathbb{A} \wedge x \in \text{Inv } R\} = \bigcap_{n>0} \left(-\frac{1}{n}, \frac{1}{n}\right) - \{0\}.$$

From this definition it follows that  $\mathbb{I} \subset \mathbb{A} \supset \Delta$  and  $\mathbb{I} \cap \Delta = \emptyset$ . Using physical terminology, we would describe non-invertible infinitesimals  $\Delta$  as ‘ultraviolet’ and invertible infinitesimals  $\mathbb{I}$  as ‘infrared’. Note that while the object  $\mathbb{A}$  needs an order relation to be defined, this relation is not necessary neither for  $\Delta$  nor for  $\mathbb{I}$ . If we would like to ‘objectivize’ now the real line  $R$ , removing all non-observable elements, we have to divide it through the ideal  $\mathbb{A}$ , introducing the ‘totally objective’ real line  $R/\mathbb{A}$ . Note that doing so we *have to* introduce ordering on this real line. This space consists only of elements which are measurable. But the price we have to pay is losing of all infinitesimal elements. Hence, in order to build some differential calculus, we have to introduce now the concept of an ‘infinitesimal limit’ in the Cauchy–Weierstrass sense, and consider all elements of this procedure – the limit and all intermediate stages — as objective, measurable ones. As a result, we get ordinary calculus with its both infrared and ultraviolet divergences which we have to regard as objective (because we work in  $R/\mathbb{A}$ ), but we cannot regard as objective (due to infinities). This paradox can be resolved only by relaxing our objectivist attitude and considering also such elements of real line which are not objective. It is one of the great advantages of the infinitesimal geometry.

A striking difference between objects  $D(W)$  and  $\mathbb{A}$  is that the former is purely geometrical and algebraic, while the latter is involved in the topology and order. While  $D(W)$  represents jets and their prolongation,  $\mathbb{A}$  represents *germs*, that is, the equivalence classes of functions on a topological space, equal on the given topological *neighbourhood* of a fixed point. (It is important to note, that the notions of germ depends on topology, but it does not depend on continuity or smoothness. Hence, in a certain sense, it is more connected with integration rather than differentiation.) One can say that the ‘level of jets’ (and of their prolongations) is the maximal nilpotent infinitesimal arena.

The crucial property of infinitesimal geometry, which is responsible for many of its advantages, is the cartesian closedness of the category in which we formulate such objects as  $R$ ,  $R^n$ ,  $D(W)$ ,  $R^{D(W)}$ , and so on. Cartesian closed category is such category that for each pair of its objects (‘sets’, ‘spaces’)  $A$  and  $B$  there exists an object  $B^A$  of all morphisms from  $A$  to  $B$ , called the *exponential*, satisfying the *exponential law*

$$\frac{A \times B \rightarrow C}{B \rightarrow C^A}, \quad (14)$$

or, equivalently,

$$\text{Hom}(A \times B, C) \cong \text{Hom}(B, C^A). \quad (15)$$

In the cartesian closed categories we have a natural way of speaking about exponential objects of all maps from one object (space) to another. It implies that the space  $R^R$  of all smooth differentiable functions from  $R$  to  $R$  is also a ring with infinitesimals, and the space  $M_2^{M_1}$  of all functions between two differentiable (*microlinear*) spaces  $M_1$  and  $M_2$  is also a differentiable space! Such construction cannot be performed in the classical set-theoretic differential geometry – the set of all maps between two fixed manifolds is not a manifold. This difference is very important for the mathematical foundation of the path-integral formulation of quantum theory and we will discuss it later.

Cartesian closedness leads also to strict equivalence between vector fields, infinitesimal flows and infinitesimal deformations of the identity maps of manifolds. Such equivalence in Newton–Weierstrass differential geometry is only a metaphor. Recall that any curve on space  $M$  may be regarded as subset  $k$  of  $M$  parametrized by the piece  $I$  of line,  $k : I \rightarrow M$ , or  $k \in M^I$ .

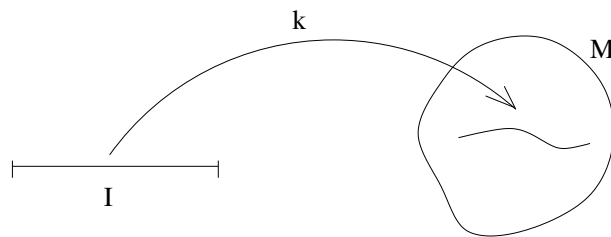

By an analogy, in order to generate space which is tangent to the space  $M$  in some point  $x$ , we should take an element  $t$  of  $M$  parametrized by an infinitesimal piece of line  $D$ .

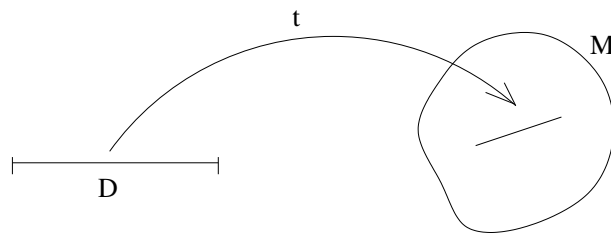

It means that the *tangent vector* attached at  $x$  is a map  $t : D \rightarrow M$  or  $t \in M^D$  such that  $t(0) = x$ . The tangent bundle is an object  $TM := M^D$  together with a map  $\pi : M^D \rightarrow M$  sending each tangent vector  $t \in M^D$  to its base point  $\pi(t) = t(0) = x$ . The set  $T_x M := M_x^D$  of tangent vectors with base point  $x$  is the tangent space to  $M$  at  $x$ . The cartesian closedness implies that there is a unique isomorphism between tangent vectors

$$X : M \rightarrow M^D,$$

infinitesimal flows on  $M$

$$X' : D \times M \rightarrow M,$$

and infinitesimal deformations of identity map of  $M$

$$X'' : D \rightarrow M^M.$$

The tangent bundle for any space is now generated by the functor  $(-)^D : M \mapsto M^D$ . Through the cartesian closedness one can concern the tangent bundle of any function space, by the isomorphism  $(M^D)^M \cong (M^M)^D$ . By definition, the tangent bundle  $M^D$  of  $M$  is also a bundle of 1-jets of  $M$ . The  $k$ -jets bundle of  $M$  is given by the object  $M^{D_k(n)}$  together with the map  $M^{D_k(n)} \rightarrow M$ . The generalized  $k$ -jet bundle (called a *prolongation*) of  $M$  is defined as  $M^{D(W)}$ .

This way the space  $TM = M^D$  of all tangent vectors of  $M$  is *literally* the space of all infinitesimal movements  $D \rightarrow M$  in infinitesimal time distance  $D$ .

## 1.6 Algebraic geometry and schemes

The main idea of algebraic geometry is to study geometrical figures defined by *solutions* of *polynomial algebraic* equations over some spaces. For example, a two-dimensional sphere with unit radius  $S^2$  placed in three-dimensional real space  $\mathbb{R}^3$  is defined by the polynomial equation

$$x^2 + y^2 + z^2 - 1 = 0, \quad (x, y, z) \in \mathbb{R}^3. \quad (16)$$

This description contains two parts:  $x^2 + y^2 + z^2 - 1 = 0$  describes the essence of the concept  $S^2$ , while  $(x, y, z) \in \mathbb{R}^3$  defines only a particular implementation (instance) of this geometric figure. Generally, the solutions of systems of polynomial equations

$$\begin{cases} f_1(x_1, \dots, x_n) = 0 \\ \vdots \\ f_m(x_1, \dots, x_n) = 0 \end{cases} \quad (17)$$

can be considered for different spaces. An *affine* algebraic geometry studies (17) over fields  $k$  which are algebraically closed, that is every (positive-degree) polynomial  $f_i \in k[x_1, \dots, x_n]$  is the product of linear polynomials. The space  $k[x_1, \dots, x_n]$  has the structure of ring, making possible the consideration of the geometrical objects (like  $S^2$ ) from the algebraic viewpoint and with its tools.<sup>5</sup> The system (17), called a *locus*, curves out a geometric shape  $A \subset k^n$  of solutions (called an *algebraic set*), but it also ‘curves out’ an ideal  $I \subset k[x_1, \dots, x_n]$ , generated by the set  $\{f_1, \dots, f_m\}$ . This ideal may be extended with all polynomials  $g$  which vanish on  $A$ , such that any natural power of  $g$  also vanishes on  $A$  (such ideals are called radical). The famous Hilbert *Nullstellensatz* states then that there is bijective correspondence between radical ideals of the ring  $k[x_1, \dots, x_n]$  and the algebraic sets  $A$  in  $k^n$ .<sup>6</sup> However, in order to study more subtle structure of geometric objects with algebraic tools, one has to move far then this duality, into the consideration of algebraic analogs of manifolds. The properties of algebraic sets

$$\begin{aligned} A(\bigcup_i I_i) &= \bigcap_i A(I_i), & k^n &= A(0), \\ A(I_1 I_2) &= A(I_1) \cup A(I_2), & \emptyset &= A(1), \end{aligned}$$

enable to use them as closed sets which define the Zariski topology.<sup>7</sup> With the help of this topology, one can define an ‘affine algebraic manifolds’, called *affine varieties*, as such algebraic sets, which are closed (in Zariski topology) and irreducible. The last term means, that an algebraic set under consideration cannot be presented as a union of two other algebraic subsets of  $k^n$ . It can be shown, that the algebraic set  $A$  is irreducible iff its ideal  $I(A)$  is prime, so the equivalent definition of an affine variety states, that it is an algebraic set  $A$  equipped with Zariski topology and with ideal  $I(A) \subset k[x_1, \dots, x_n]$  which is prime (one can treat this as a generalisation of *Nullstellensatz*, because every maximal ideal is prime, but not converse). The Zariski topology can be also formulated directly on the set  $\text{Spec}(k[x_1, \dots, x_n])$  of prime ideals, by defining closed subsets  $V(I) \subset \text{Spec}(k[x_1, \dots, x_n])$  as such that consist of all ideals in  $\text{Spec}(k[x_1, \dots, x_n])$  which contain  $I$  as a subset. Taking the dual view, we may say that  $V(I)$  consist of ideals of all affine subvarieties (with respect to the Zariski topology on  $k^n$ ) which are contained in  $A(I)$ . Hence, these two definitions are compatible, however the definition of Zariski topology on the spectrum of ring is more general. In effect, we can notice that the duality

<sup>5</sup>The basic model of this inteploy is the fundamental theorem of algebra, which states that every polynomial over  $\mathbb{C}$  (an algebraic object) bijectively corresponds to the set of its roots (a geometric object).

<sup>6</sup>More precisely, algebraic sets are not subobjects of cartesian product  $k^n$ , but of affine space  $\mathbb{A}_k^n$ , that is,  $k^n$  without origin, what removes the possibility of addition of points.

<sup>7</sup>In other words, closed sets in Zariski topology on  $k^n$  are given by  $A(U) = \{x \in k^n \mid f(x) = 0 \ \forall f \in U \subset k[x_1, \dots, x_n]\}$ . This definition implies that Zariski topology is generally neither Hausdorff, nor Tychonoff.

between polynomials over  $\mathbb{C}$  and set of its roots, extended to Nullstellensatz duality between algebraic sets and radical ideals, has been ‘substituted’ on a higher level by the duality between affine varieties and spectrum of prime ideals with Zariski topology.

By taking an ideal  $I(X)$  corresponding to some algebraic set  $X$ , and dividing  $k[x_1, \dots, x_n]$  by it, one obtains the *affine coordinate ring* of  $X$ . The duality between algebraic and geometric description can be observed in the fact that two affine algebraic varieties are isomorphic iff their affine rings are isomorphic.

The affine varieties are geometrical objects which generalize the space of solutions of (17). For a given affine variety  $A$  some of its points (given by maximal ideals) correspond to particular points in  $k^n$ , but there are also other points, given by non-maximal prime ideals, corresponding to subvarieties of  $A$ . Hence, affine varieties are more general than affine sets, but this way they enable to encode more information about the geometrical structure. Further generalizations which we will consider, namely schemes, topoi and stacks, follow the same path: they enhance the expressible power of duality between geometry and algebra through generalization of the structure.

The idea of Grothendieck, which has radically extended the range of the applicability of algebraic geometry, was to consider a space as a spectra of a commutative ring (with no additional assumptions). He called such space an *affine scheme*. But even more striking was his idea of a *scheme*, that is, a space which is *locally* reconstructed from an algebra (locally isomorphic to an affine scheme). Such scheme can be thought of as an entity ‘glued’ from affine schemes, but from more fundamental perspective, it is a space which arises from *localisation* of a given algebraic structure.

An *affine scheme* was defined by Grothendieck as the space  $\text{Spec}R$  of prime ideals a commutative ring  $R$ , equipped with the Zariski topology and a sheaf of commutative rings of polynomial functions defined over the Zariski open sets of the spectrum. The ring of global sections of this sheaf is equal to  $R$ . A *scheme* is a space equipped in a topology and a sheaf of commutative rings, such that the restriction of a sheaf to every open set is a ring which spectra is an affine scheme. This way affine schemes provide an algebraic analogue of coordinate systems on schemes. The latter are often viewed just as topological spaces, which are equipped with (sheaves of) commutative rings assigned to all its open sets, and arising from ‘gluing’ of the spectra of these rings. This ‘gluing’ perspective, representing covariant point of view (that is, considering space as arising from certain imbeddings of smaller constituents) may be more easy to grasp, but is less general. As observed by Grothendieck, and advocated by Lawvere, generally in all algebraic geometry the contravariant structures are more well behaved (eg. cohomology as opposed to homology). In the case of schemes, the contravariant perspective leads to consideration of local spaces (affine schemes) as a result of localisation of certain global structure. In this sense, the local space (affine) is ‘taken out’ from the global object (scheme).

A particular example of a scheme is an algebraic *variety*, which is a scheme which sheaf consists of finitely generated  $k$ -algebras (quotients of polynomial  $k$ -algebras by prime ideals), for any field  $k$ . Again, variety could be considered as a ‘glueing’ of affine varieties along common open sets, but it is better to consider it as a localisation of a certain algebraic object.

A Grothendieck topos provides a further generalisation of this idea: it is a generalized topological space, equipped with the set-valued functors assigned to this space. Due to Yoneda embedding, every object of the base topological space can be represented fully and faithfully in terms of the set-valued functor. While schemes are categories of sheaves of commutative algebras over the space equipped locally with Zariski topology, toposes are sheaves of sets over categories equipped with Grothendieck topology.

## 1.7 Algebraic differential geometry and toposes

So far we have discussed the system of infinitesimal analysis and geometry build axiomatically “from scratch”. However, at the end of the day we have to pose the question which categories are properly modeling this system, as well as what is the general relation between this system and the classical differential calculus and geometry. The general solution of this problem was proposed by Lawvere [L] in analogy with some methods of algebraic geometry, and was developed by Dubuc [D], Kock [K], Reyes [R], Moerdijk [M] and others. It appears that good models of infinitesimal analysis and geometry can be provided inside special type of categories, known as topoi. In order to understand this construction, we have to reconsider to issues related with algebraic geometry and classical differential geometry.

Every ordinary smooth differential manifold  $M$  may be equivalently described by the algebra  $C^\infty(M)$  of smooth functions over it. The set of points of this manifold appears as the spectrum of the given algebra  $C^\infty(M)$  and all structures on this set may be restored from the given corresponding structures of  $C^\infty(M)$  (see eg. [JetNestruev] for details).<sup>8</sup> The approach of interpreting manifolds in terms of (sheaves of) rings is the standard tool in algebraic geometry. In particular, every affine scheme is equivalent to a certain commutative ring (and the category of affine schemes is just dual to the category commutative rings with unit), while every scheme, consisting of affine schemes, is described by sheaf of rings. Such algebraic perspective on geometrical objects became very fruitful in the area of algebraic geometry, but it was not used in the classical differential geometry due to concrete obstacles which characterize the category **Man** of classical smooth differential manifolds. The category **Man** lacks finite inverse limits, what means that the projective limit  $\varprojlim_{i \in I} U_i$  of manifolds  $U_i$  as well as fiber products  $U_i \times_{U_j} U_k$  generally are not manifolds. Hence, one cannot consider differential curves and manifolds with singularities as differential manifolds, thus many tools of algebraic geometry become unavailable for studying **Man**. The second disadvantage on **Man** is lack of cartesian closedness, what means that the function space  $A^B$  of all smooth maps between the manifolds  $A$  and  $B$  is not a manifold, and there is no equivalence between  $A \times B \rightarrow C$  and  $B \rightarrow C^A$ . Physically it means that if one considers, following [Lawvere:1980],  $A$  as object of (all possible states of) time,  $B$  as object of some physical body, and  $C$  as some space, then the motion  $A \times B \rightarrow C$  is not equivalent to the assignment  $B \rightarrow C^A$  of the body to its path in the space. This implies also foundational problems in calculus of variations and in functional integration (because function spaces do not belong to **Man**).

These problems can be solved by considering the category  $\mathbb{L}$  of formal smooth varieties instead of **Man**. Like in the case of affine algebraic varieties,  $\mathbb{L}$  is defined as the category dual to the category of certain commutative unital rings. These rings are called  $C^\infty$ -rings (or  $C^\infty$ -algebras), and are defined as such finitely generated rings  $A$  in which one can functorially interpret any smooth function  $f : \mathbb{R}^n \rightarrow \mathbb{R}^m$  as the map  $\tilde{f} : A^n \rightarrow A^m$ , such that all projection, composition and identity maps on  $\mathbb{R}^n$  are preserved by corresponding maps on  $A^n$ . A concrete example of  $C^\infty$ -ring is naturally the ring  $C^\infty(M)$  of smooth functions over some manifold  $M \in \mathbf{Man}$ . It can be shown [MoerdijkReyes] that there exists unique full and faithful contravariant functor from **Man** to the category of  $C^\infty$ -rings which assigns finitely presented  $C^\infty(M)$  to each  $M$ . This also implies that the dual category  $\mathbb{L}$  of formal smooth varieties embeds **Man** fully and faithfully (the embedding functor **Man**  $\rightarrow \mathbb{L}$  is denoted  $s$ ). Objects of the category  $\mathbb{L}$  generalize the notion of the differential manifold, because  $\mathbb{L}$  contains (finite) projective limits, including spaces with singularities as a kind of generalized (“formal”) smooth manifold (variety). Moreover, it contains also infinitesimal spaces, such as  $D(\ell A) = \{x \in \ell A \in \mathbb{L} | x^2 = 0\}$ . However, it is

<sup>8</sup>In other words, the smooth differential manifold is a topological space  $X$  equipped with a sheaf  $C^\infty(X)$  of smooth functions over  $X$  such that the pair  $(X, C^\infty(X))$  is locally isomorphic to  $(\mathbb{R}^n, C^\infty(\mathbb{R}^n))$ .

not cartesian closed, so it cannot be used to model the system of infinitesimal analysis. In order to achieve cartesian closeness, one has to embed  $\mathbb{L}$  in the category  $\mathbf{Set}^{\mathbb{L}}$  of presheaves over  $\mathbb{L}$ . The latter category consists of the set-valued functors  $\mathbb{L}^{op} \rightarrow \mathbf{Set}$ . The embedding  $\mathbb{L} \hookrightarrow \mathbf{Set}^{\mathbb{L}^{op}}$  is provided by the standard technique of full and faithful Yoneda embedding functor  $Y : \mathbb{L} \ni A \mapsto \text{Hom}(-, A) \in \mathbf{Set}^{\mathbb{L}^{op}}$ . The category  $\mathbf{Set}^{\mathbb{L}}$  is cartesian closed and has finite projective limits as well as contains infinitesimal spaces, so it can be used as a category for modeling axioms of infinitesimal geometry. The category of ordinary differential manifolds is fully and faithfully embedded in  $\mathbf{Set}^{\mathbb{L}}$  by the sequence of functors

$$\mathbf{Set} \xleftarrow{U} \mathbf{Man} \xrightleftharpoons[\Gamma]{s} \mathbb{L} \xrightarrow{Y} \mathbf{Set}^{\mathbb{L}}$$

It is worth to note that nilpotent infinitesimals appear also in Grothendieck's theory of schemes, in form of nilpotent affine schemes. However, due to lack of appropriate language (and semantics), they cannot be directly handled and exploited. This is possible only after embedding of nilpotent schemes, together with other schemes, into suitable topos.

An axiomatic system of infinitesimal geometry and analysis cannot be non-trivially modelled in the category  $\mathbf{Set}$ , because Kock–Lawvere axiom is inconsistent with Boolean logic, and sets are, according to Stone representations theorem, models of Boolean logic. The well-adapted model of this system should be a category which enables usage of intuitionistic logic (representations of non-Boolean Heyting algebras), is cartesian closed, and has finite limits. Moreover, it should make the spectra  $D(W) = \text{Spec}_R W$  of Weil algebras representable, and ensure the validity of Kock–Lawvere axiom (as well as some other axioms, according to purposes).

In topos models of infinitesimal geometry which do not contain invertible infinitesimals, the object  $D(W)$  is equal to the object of all infinitesimals  $\mathbb{A}$ , which is the ideal of  $R$ . On the other hand, in models with invertible infinitesimals (like  $\mathcal{Z}$  and  $\mathcal{B}$ ), not only underlying logic is weakened to intuitionistic, but also the underlying *arithmetic* is weakened. This means that the space  $N = Y(\ell C^\infty(\mathbb{N}))$  *does not* coincide with the generic natural number objects (constant set-valued sheaf of natural numbers) of toposes  $\mathcal{Z}$  and  $\mathcal{B}$ . The former expresses the weakened, nonstandard arithmetic. The object  $\mathbb{I}$  is modelled by a Yoneda embedding of the  $C^\infty$ -ring  $C^\infty(\mathbb{R} - \{0\}) / (m_{\{0\}}^g |_{\mathbb{R} - \{0\}})$ . The weakening of arithmetic means restriction of the validity of the induction.<sup>9</sup>

## 1.8 Well-adapted topos models of infinitesimal analysis and geometry

$Sh(\mathbb{L})$  arises from  $\mathbf{Set}^{\mathbb{L}}$  after equipping the base category  $\mathbb{L}$  of sheaves over  $\mathbb{L}$  with some kind of Grothendieck topology  $J$ .  $Sh(\mathbb{L})$  is a subcategory of  $\mathbf{Set}^{\mathbb{L}}$  containing as objects all contravariant functors from  $\mathbb{L}$  to  $\mathbf{Set}$  which form sheaves with respect to the Grothendieck topology  $J$  on  $\mathbb{L}$ .

The functorial assignment  $\mathbf{Set}^{C^{op}} \rightarrow Sh_J(\mathcal{C})$  is called a *sheafification* functor and is valid for any given category  $\mathcal{C}$  and Grothendieck topology  $J$  on  $\mathcal{C}$ . The pair  $(\mathcal{C}, J)$  is called a *site*.

We would like to use object of  $Sh(\mathbb{L})$  as spaces which satisfy the Kock–Lawvere axiom. This axiom is inconsistent with the classical logic, so due to Stone representation theorem (duality [Stone:1934], according to which every Boolean algebra is isomorphic to the lattice of closed–and–open subsets of set-theoretical space, it cannot be non-trivially modelled within the category  $\mathbf{Set}$  of sets. Leaving aside the axiom of excluded middle, we implicitly perform a generalisation

<sup>9</sup>As noticed by Gonzalo Reyes, such formulation gives a potential possibility to overcome the restrictions of Gödel theorem in the way suggested by Lawvere: namely by considering natural numbers of geometric, rather than of arithmetic (in Peano sense) origin.

from Boolean to Heyting algebras, so we have to find some universe adequate for representation of such algebras. Heyting algebras share with the Boolean ones all logical connectives and properties except the law of excluded middle (which is equivalent to the statement that double negation means affirmation). The well-known example of the representation of Heyting algebra are the open subsets  $\mathcal{O}(X)$  of the given topological space  $X$ . If we define logical connectives as

$$\begin{aligned} A \wedge B &:= A \cap B, \\ A \vee B &:= A \cup B, \\ 1 &:= X, \\ 0 &:= \emptyset, \\ \neg A &:= \text{Int}(X - A), \\ A \Rightarrow B &:= \text{Int}((X - A) \cup B), \end{aligned} \tag{18}$$

where  $A$  and  $B$  are open subsets of  $X$ , and  $\text{Int}(C)$  means the maximal open subset of  $C$ , we can check that these open subsets satisfy all axioms of Boolean logic except the one of the excluded middle. For example, if  $X = \mathbb{R}$ , and  $A := \{x \in \mathbb{R} | x < 7\}$ , then  $\neg A = \{x \in \mathbb{R} | x > 7\}$ , hence  $A \vee \neg A \neq 1$ , so open subsets of  $\mathbb{R}$  form a non-Boolean Heyting algebra representation. It appears that the more general structure, the category  $\mathbf{Set}^{\mathcal{O}(X)^{op}}$  of hom-functors (presheaves)  $\text{Hom}(-, A)$  over the category of topological spaces  $\mathcal{O}(X)$ , defined as

$$\mathcal{O}(X) \ni B \mapsto \text{Hom}(B, A) \in \mathbf{Set}, \tag{19}$$

for any  $A \in \mathcal{O}(X)$ , also contains a representation of Heyting algebra. It is given by the lattice  $\text{Sub}(\text{Hom}(-, A))$  of the subfunctors of functor  $\text{Hom}(-, A)$ . One can check it evaluating this functor for any  $B \in \mathcal{O}(X)$  as a lattice of subsets of the set  $\text{Hom}(B, A)$ .

$\mathbf{Set}^{\mathcal{O}(X)}$  is an example of Grothendieck topos. Lawvere and Tierney have found that in every topos we can find the functor, denoted as  $\Omega$  and called a *subobject classifier*, that is explicitly responsible for the characteristic functions of subsets. It appears that the subobject classifier in topos has always the structure of Heyting algebra, hence the statement

$$\begin{aligned} \chi_A(B) &= 1 \quad \text{if } A \subset B, \\ \chi_A(B) &= 0 \quad \text{otherwise} \end{aligned} \tag{20}$$

is not universally satisfied. In the more general class of toposes of presheaves  $\mathbf{Set}^{\mathcal{C}^{op}}$ , where  $\mathcal{C}^{op}$  is categorical dual to any category  $\mathcal{C}$ ,  $\Omega$  is a hom-functor (from the point of view of  $\mathcal{C}^{op}$ ) and an object (from the point of view of  $\mathbf{Set}^{\mathcal{C}^{op}}$ ), that classifies subobjects of  $\mathbf{Set}^{\mathcal{C}^{op}}$ . Using the logical properties of  $\Omega$  we can ‘speak inside the topos’ through its internal language based on the Heyting algebra of the intuitionistic logic. If we want to concern some category with good topological properties, we have to equip the base category  $\mathcal{C}$  with some kind of Grothendieck topology  $J$ , and form the *Grothendieck topos* of sheaves  $\text{Sh}_J(\mathcal{C}^{op})$  over the site  $(\mathcal{C}, J)$ .  $\text{Sh}_J(\mathcal{C}^{op})$  is a subcategory of  $\mathbf{Set}^{\mathcal{C}^{op}}$ , and is called also a sheafification of  $\mathbf{Set}^{\mathcal{C}^{op}}$ , because is constructed by all functors in  $\mathbf{Set}^{\mathcal{C}^{op}}$  which form sheaves with respect to the Grothendieck topology  $J$  on  $\mathcal{C}^{op}$ .

Hence, in general, we may try to interpret SDG/SIA in some topos, particularly in some topos of sheaves over a given site, thanks to the inner Heyting algebra structure of the subobject classifier of an elementary topos. This means that instead of the system of classical differential calculus and geometry based on the concept of limits and interpretation of this system in set theory, we can use a system of synthetic differential calculus and geometry based on the concept of infinitesimals and interpretation of this system in topos theory.

Every interpretation of axioms of SDG/SIA in a particular category is called a *model*. By the obvious reasons, we are at most interested in such models of SDG/SIA which allow to establish



the link between the ‘classical’ analytic post-Weierstassian differential calculus and geometry with the synthetic one. The structure of SDG/SIA implies that we have to work in complete cartesian closed category, but the fact, that we have to interpret the intuitionistic logic of statements somehow ‘naturally’ inside this category, leads us to the assumption that we will work in a topos, which is complete and cocomplete cartesian closed category with the subobject classifier.

One of the simplest models of SIA/SDG is the topos  $\mathbf{Set}^{\mathbf{R-Alg}}$  of set-valued functors from the category  $\mathbf{R-Alg}$  of (finitely presented)  $\mathbb{R}$ -algebras to the category  $\mathbf{Set}$  of sets<sup>10</sup>. Each such functor is a forgetful functor, which associates to an  $\mathbb{R}$ -algebra the set of its elements, and to every homomorphism  $f$  of  $\mathbb{R}$ -algebras the same  $f$  as function on sets. We induce commutative unital ring structure on functors  $R \in \mathbf{Set}^{\mathbf{R-Alg}}$  in the following natural way: for every  $A \in \mathbf{R-Alg}$  we consider a ring  $R(A)$ , together with operations of addition  $+_A : R(A) \times R(A) \rightarrow R(A)$  and multiplication  $\cdot_A : R(A) \times R(A) \rightarrow R(A)$ , which are natural in the sense, that they are preserved by the homomorphisms in  $\mathbf{R-Alg}$ , thus also by the corresponding functors  $\mathbf{R-Alg} \rightarrow \mathbf{Set}$ . The functor  $R$  is a model of a synthetic real line  $R$ , while an object  $D \subset R$  has the following interpretation in  $\mathbf{Set}^{\mathbf{R-Alg}}$ :

$$\mathbf{R-Alg} \ni A \xrightarrow{D} D(A) = \{a \in A \mid a^2 = 0\}. \quad (21)$$

The functorial construction of models may look quite esotherical at first sight, but in fact it strictly expresses the difference and the link between our *concepts* and their *models*. One should note that our concepts are formulated in abstract and ‘background-free’ way: as some relations between objects and elements. For example, the *concept* (an algebraic *locus*) of a sphere  $S^2$  is

$$S^2 = \{(x, y, z) \mid x^2 + y^2 + z^2 = 1\}. \quad (22)$$

We may now take different backgrounds to express  $S^2$ , for example, by saying that elements of  $S^2$  should belong to some commutative  $\mathbb{R}$ -algebra (to some object in the category  $\mathbf{R-Alg}$ ). To ‘see’ somehow ‘naturally’ how such sphere  $S^2$ , expressed in terms of  $\mathbf{R-Alg}$ , ‘looks like’ we use the set-theoretical ‘eyes’ or ‘screen’. This leads us to demand that  $S^2$  should give as an output the *set* of triples of elements of  $A \in \mathbf{R-Alg}$  which satisfy the ‘conditions’ given in the definition of  $S^2$ . So, the *interpretation* (*model*) of the concept (locus)  $S^2$  is a set-valued *functor*  $\mathbf{Set}^{\mathbf{R-Alg}}$ :

$$\mathbf{R-Alg} \ni A \xrightarrow{S^2} S^2(A) = \{(x, y, z) \in A^3 \mid x^2 + y^2 + z^2 = 1\} \in \mathbf{Set}, \quad (23)$$

which means that  $S^2$  is modelled by the functor which takes these elements from the ring  $A$  which fit the pattern  $x^2 + y^2 + z^2 = 1$ , and produces a set which contains them. Recall that the global elements of  $R(A)$  are the arrows  $\mathbf{1} \rightarrow R(A)$ . The  $\mathbb{R}$ -algebra corresponding to  $\mathbf{1} \cong \{*\}$  is the  $\mathbb{R}$ -algebra with one generator  $\mathbb{R}[X]$ , while the arrow corresponding to  $\mathbf{1} \xrightarrow{\lceil x \rceil} R(A)$  is an  $\mathbb{R}$ -algebra homomorphism  $\mathbb{R}[X] \xrightarrow{\phi_x} A$ . This means that

$$R \cong \text{Hom}_{\mathbf{R-Alg}}(\mathbb{R}[X], -), \quad (24)$$

is a representable functor:

$$R(A) \cong \text{Hom}_{\mathbf{R-Alg}}(\mathbb{R}[X], A). \quad (25)$$

By the Yoneda Lemma

$$\text{Hom}(R, R) \cong \text{Nat}(\text{Hom}(\mathbb{R}[X], -), \text{Hom}(\mathbb{R}[X], -)) \cong \text{Hom}(\mathbb{R}[X], \mathbb{R}[X]), \quad (26)$$

<sup>10</sup>We consider  $\mathbb{R}$ -algebras based on  $\mathbb{R} \in \mathbf{Set}$ , but we could consider also  $\mathbb{R}_C$ - or  $\mathbb{R}_D$ -algebras build from Cauchy or Dedekind reals of some topos. We will assume also that all algebras and rings considered in this section are finitely presented.

so the maps  $f : R \rightarrow R$  on the ring  $R$  (from the synthetic point of view) are the maps of polynomials with coefficients in  $\mathbb{R}$  (from the interpretational point of view). It can be shown (see [Kock:1981] for details), that  $\mathbf{Set}^{\mathbb{R}\text{-Alg}}$  satisfies the generalized Kock-Lawvere axiom (and weak version of integration axiom), but it does not satisfy other axioms. Thus there is a need to consider different models (universes of interpretation).

Note that  $\mathbb{R}\text{-Alg}$  of  $\mathbb{R}$ -algebras is defined as a category of arrows  $f_A : \mathbb{R} \rightarrow A$ , where commutative rings  $A$  are such that  $xy = yx$  for every  $x \in f_A(\mathbb{R})$  and for every  $y \in \mathbb{R}$ . Hence, we may consider the category  $\mathbb{R}\text{-Alg}$  as the category of rings  $A$  equipped with the additional structure given by the maps  $A^n \xrightarrow{f_A(p)} A^m$  preserving the structure of polynomials  $p = (p_1, \dots, p_n) : \mathbb{R}^n \rightarrow \mathbb{R}^m$  in such way that identities, projections and compositions are preserved:  $f_A(\text{id}) = \text{id}$ ,  $f_A(\pi) = \pi$  and  $f_A(p \circ q) = f_A(p) \circ f_A(q)$ . This means that construction of  $\mathbb{R}$ -algebras and  $C^\infty$ -algebras is similar.

*There should be many algebraic theories  $\mathcal{A}$  intermediate between only polynomials as operations and all  $C^\infty$  functions as operations, perhaps satisfying some suitable closure conditions, in particular the  $\mathcal{A}$  generated by  $\cos$ ,  $\sin$ ,  $\exp$ ,  $e^{-1/x^2}$ . [Lawvere:1979]*

It can be shown, using the Hadamard lemma, that  $C^\infty$ -ring divided by an ideal is  $C^\infty$ -ring.

Another important example of  $C^\infty$ -ring is a ring of *germs* of smooth functions.

**Definition 1.1** A *germ* at  $x \in \mathbb{R}^n$  is an equivalence class of such  $\mathbb{R}$ -valued functions which coincide on some open neighbourhood  $U$  of  $x$ , and is denoted as  $f|_x$  for some  $f : U \rightarrow \mathbb{R}$ . We denote a ring of germs at  $x$  as  $C_x^\infty(\mathbb{R}^n)$ . If  $I$  is an ideal, then  $I|_x$  is the object of germs at  $x$  of elements of  $I$ .

Of course,  $C_x^\infty(\mathbb{R}^n)$  is a  $C^\infty$ -ring and  $I|_x$  is an ideal of  $C_x^\infty(\mathbb{R}^n)$ . The **object of zeros**  $Z(I)$  of an ideal  $I$  is defined as

$$Z(I) = \{x \in \mathbb{R}^n \mid \forall f \in I \quad f(x) = 0\}. \quad (27)$$

We may introduce the notion of **germ-determined ideal** as such  $I$  that

$$\forall f \in C^\infty(\mathbb{R}^n) \quad \forall x \in Z(I) \quad f|_x \in I|_x \Rightarrow f \in I. \quad (28)$$

The *dual* to the full subcategory of (finitely generated)  $C^\infty$ -rings whose objects are of form  $C^\infty(\mathbb{R}^n)/I$  such that  $I$  is germ-determined ideal is denoted by  $\mathbf{G}$  (we take the *dual* category, because we want to make a topos of presheaves  $\mathbf{Set}^{\mathbf{G}^{op}}$ , where sets will be varying on the (finitely generated)  $C^\infty$ -rings and not on their duals). Recall that for  $\mathbb{R}$ -algebras we used the functor

$$\mathbb{R}\text{-Alg} \ni A \longmapsto R(A) \in \mathbf{Set}, \quad (29)$$

as the model (interpretation) of the naive-SDG ring  $R$  in the topos  $\mathbf{Set}^{\mathbb{R}\text{-Alg}}$ . In the same way we may define the interpretation of the ring  $R$  in the topos  $\mathbf{Set}^{\mathbf{G}^{op}}$ :

$$\mathbf{G}^{op} \ni A \longmapsto R(A) \in \mathbf{Set}. \quad (30)$$

The topos  $\mathbf{Set}^{\mathbf{G}^{op}}$  of presheaves over the category of germ-determined  $C^\infty$ -rings equipped with the Grothendieck topology is called the **Dubuc topos**, and is denoted by  $\mathcal{G}$ .<sup>11</sup> This topos is not only very good well-adapted model of SDG, but it also has a good representation of classical paracompact  $C^\infty$ -manifolds.

<sup>11</sup>More precisely, the topos  $\mathcal{G}$  is a subcategory of  $\mathbf{Set}^{\mathbf{G}^{op}}$  obtained by sheafification, and we have an inclusion  $\mathcal{G} \hookrightarrow \mathbf{Set}^{\mathbf{G}^{op}}$ . The left adjoint  $a : \mathbf{Set}^{\mathbf{G}^{op}} \rightarrow \mathcal{G}$  is called the **sheafification functor**. In other words,  $\mathcal{G}$  is the topos of *sheaves* on  $\mathbf{G}$ .

For some purposes we can also use the larger topos  $\mathbf{Set}^{\mathbf{L}^{op}} := \mathbf{Set}^{C^\infty}$ . It does not have the interpretation for an axiom R2 of local ring and an axiom N3 of Archimedean ring, but it is a good toy-model, easier to concern than  $\mathcal{G}$  is. Note that the equation (356):

$$R(A) \cong \mathbb{R}\text{-Alg}(\mathbb{R}[X], A) \tag{31}$$

has an analogue in case of the interpretation of SDG in topos  $\mathbf{Set}^{\mathbf{L}^{op}}$ :

$$R(\ell A) \cong \mathbf{Set}^{\mathbf{L}^{op}}(\ell A, \ell C^\infty(\mathbb{R})), \tag{32}$$

where  $\ell C^\infty(\mathbb{R})$  is the  $C^\infty$ -ring (the symbol  $\ell$  denotes here the fact, that we are working within the category which is dual to that of  $C^\infty$  rings). Thus, a real line of an axiomatic SDG becomes now

$$R \cong \text{Hom}_{\mathbf{Set}^{\mathbf{L}^{op}}}(-, \ell C^\infty(\mathbb{R})), \tag{33}$$

or, using the formal logical sign which denotes interpretation in the model,

$$\mathbf{Set}^{\mathbf{L}^{op}} \models R \cong \text{Hom}_{\mathbf{Set}^{\mathbf{L}^{op}}}(-, \ell C^\infty(\mathbb{R})). \tag{34}$$

This means that the element of ring  $R$ , the real number of naive intuitionistic set theory, is some morphism  $\ell A \rightarrow \ell C^\infty(\mathbb{R})$ . We say that we have a **real at stage**  $\ell A$ . Thus, our *concept* of the real line  $R$  of Synthetic Differential Geometry can be *modelled (interpreted)* by the different rings (stages) of smooth functions on the *classical* space  $\mathbb{R}^n$  (which can be, however, defined categorically, as an  $n$ -ary product of an object  $\mathbb{R}_D$  of Dedekind reals in the Boolean topos  $\mathbf{Set}$ ). For example, at the stage  $\ell A = C^\infty(\mathbb{R}^n)/I$ , where  $I$  is some ideal of the ring  $C^\infty(\mathbb{R}^n)$ , a *real (real variable, real number)* is an equivalence class  $f(x) \bmod I$ , where  $f \in C^\infty(\mathbb{R}^n)$ . An interpretation of the most important (naive) objects of SDG is following ([Moerdijk:Reyes:1991]):

smooth real line	$R = Y(\ell C^\infty(\mathbb{R})) = s(\mathbb{R})$
point	$\mathbf{1} = Y(\ell(C^\infty(\mathbb{R})/(x))) = s(\{*\}) = \{x \in R \mid x = 0\}$
first-order infinitesimals	$D = Y(\ell(C^\infty(\mathbb{R})/(x^2))) = \{x \in R \mid x^2 = 0\}$
$k^{\text{th}}$ -order infinitesimals	$D_k = Y(\ell(C^\infty(\mathbb{R})/(x^{k+1}))) = \{x \in R \mid x^{k+1} = 0\}$
infinitesimals	$\Delta = Y(\ell C_0^\infty(\mathbb{R})) = \{x \in R \mid \forall n \in \mathbb{N} \quad -\frac{1}{n+1} < x < \frac{1}{n+1}\}$

The symbol  $Y$  denotes the Yoneda functor  $\text{Hom}(-, \ell A) =: Y(\ell A)$ , while  $s$  denotes the functor  $s : \mathbf{Man}^\infty \rightarrow \mathbf{Set}^{\mathbf{L}^{op}}$ , introduced in the proposition 11.3 (the symbol  $Y$  is often omitted, so one writes  $\ell C^\infty(\mathbb{R})/I$  instead of  $Y(\ell C^\infty(\mathbb{R})/I)$ ).

It seems that the ‘heaven of total smoothness’ of SDG should be somehow paid for. And indeed, it is. The simplification of a structure of geometrical theory raises the complication of its interpretation: we have to construct special toposes for interpreting SDG, going beyond set theory and the topos  $\mathbf{Set}$ . However, such complication may unexpectedly become a solution of many of our problems. Particularly, the well-adapted model  $\mathcal{G}$  of SDG is a topos of functors from (sheafified germ-determined duals of)  $C^\infty$ -rings to  $\mathbf{Set}$ , which means that we express differential geometry not in terms of points on manifold, but through such smooth functions on it, which have the same *germ*, what means that they coincide on some neighbourhood. In the Dubuc topos  $\mathcal{G}$  we have the interpretation (identification):

the real line $R \cong$ a functor $R : C^\infty \supset \mathbf{G}^{op} \longrightarrow \mathbf{Set}$
---

## 2 From Kock–Lawvere axiom to microlinear spaces

We want to express geometric constructions in a synthetic manner, thus in algebraic (as opposite to analytic) and constructive way. This approach is powered by the view, that geometric constructions really *are* algebraic, as far as theory describes our concepts which should be more general than particular structure of one fixed (mathematical, physical) universe.

In category-theoretic terms we may speak about constructions as arrows and about forms generated by these constructions as objects. Considering cartesian closed categories we have also a natural way of speaking about exponential objects of all arrows from one object to another. As we will see, handling SDG in some cartesian closed category, we can consider two manifolds  $M_1$  and  $M_2$  as well as their exponential object  $M_2^{M_1}$  being *the manifold* of all maps (arrows) from  $M_1$  to  $M_2$ . Such construction cannot be done in a classical set-theoretic differential geometry – the set of all maps between two fixed manifolds is not a manifold.

Comming back to our intention of establisishing the close correspondence between algebra and geometry, we can consider the geometric line as a commutative ring structure  $R$ . If we will state that there exists such

$$D := \{x \in R \mid x^2 = 0\} \subset R \quad (35)$$

that  $D \neq \{0\}$ , then  $R$  cannot be a field (because there are such elements that are nilpotent but not invertible), and should remain commutative ring. Condition  $D \neq \{0\}$ , roughly speaking, means that there exists some element  $x \in R$  not equal to zero, but ‘such small’ that  $x^2 = 0$ . These are so-called (*first-order*) *infinitesimals*, which can be used to express the fundamental axiom of synthetic differential geometry.

### Kock–Lawvere axiom

$$\forall g \in R^D \quad \exists! b \in R \quad \forall d \in D \quad g(d) = g(0) + d \cdot b. \quad (36)$$

The notation  $g \in R^D$  one reads of course as ‘function  $g$  from  $D$  to  $R$ ’ (and it means that we intend to work in some cartesian closed category, i.e. in the category with exponentials). This axiom says that the graph of  $g$  coincides on  $D$  with a straight line with slope  $b$  going through  $(0, g(0))$ . For the case of  $R \times R$ , we can draw it as

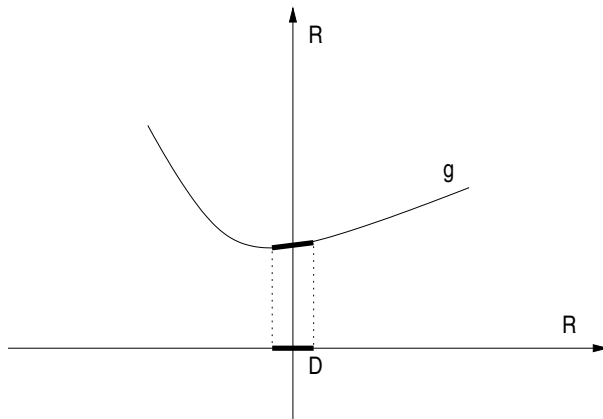

where the line tangent to  $g$  at  $0$  is tangent on an infinitesimal part of domain  $D \subset R$ . This happens not in the sense of a limit in a point, but ‘really’: on a part of domain (what means that every function is infinitesimally linear). However, the Kock–Lawvere axiom leads straight forward to an important proposition.

**Proposition 2.1** *The Kock-Lawvere axiom is not compatible with the law of excluded middle.*

**Proof.** Let's define a function  $g : D \rightarrow R$  such that

$$\begin{cases} g(d) = 1 & \text{iff } d \neq 0, \\ g(d) = 0 & \text{iff } d = 0. \end{cases} \quad (37)$$

Kock-Lawvere axiom implies that  $D \neq \{0\}$ , because otherwise  $b$  would be not unique. So (using the law of excluded middle) we may assume that there exists such  $d_0 \in D$  that  $d_0 \neq 0$ . From the Kock-Lawvere axiom we have immediately  $1 = g(d_0) = 0 + d_0 \cdot b$ . After squaring both sides we receive  $1 = 0$ .  $\square$

This result means that we cannot make anything meaningful based on Kock-Lawvere axiom using the logic in which the law of excluded middle holds. However we are not restricted to such logic, and we can use intuitionistic logic to develop our synthetic differential geometry theory. It can be properly done if we will make all proofs in a constructive manner, proper for intuitionistic logic.

**Definition 2.2** *An object  $A$  is **decidable**<sup>12</sup> if*

$$\forall x, y \in A \quad \vdash (x = y) \vee (x \neq y). \quad (38)$$

**Corollary 2.3**  *$R$  is not decidable.*

Such theory, build using the constructive reasoning and intuitionistic logic, obviously cannot be properly interpreted in **Set**, but it can be done in some topos, because of the inner structure of subobject classifier which is Heyting algebra (and the corresponding fact, that the poset of subobjects of some fixed object is also Heyting algebra). So, instead of the system of classical differential geometry based on the concept of limits and interpretation of this system in set theory,<sup>13</sup> we can develop a system of synthetic differential geometry based on the concept of infinitesimals and interpretation of this system in topos<sup>14</sup> theory. We can even compare these two systems concerning so called well-adapted models of SDG. In sections 2.1-2.5 we will develop system of differential geometry based on the Kock-Lawvere axiom. In section 2.6 we will consider the question how such axiomatic construction based on existence of  $D \subset R$  is relevant to our presuppositions about the real line. To achieve more meaningful theory we will introduce (axiomatically) ordering  $<$  and partial ordering  $\leq$  on ring  $R$  and will inspect how this structure corresponds to well-known constructions of Cauchy and Dedekind reals. In the same section we will introduce the object of natural numbers (till this, we will handle naively our intuitionistic set theory concerning that natural numbers are available). In section 2.7 we will introduce coordinates

<sup>12</sup>Generally, a property  $P$  on object  $A$  is decidable if  $\vdash (P(x) \vee \neg P(x))$  for every  $x \in A$ . Thus, the defined above 'decidability' is only 'decidable equality'. However, by the Kock-Lawvere axiom,  $R$  is not decidable also in the general sense. For example, order  $<$  on  $R$  (defined in the section 2.6) is also not decidable.

<sup>13</sup>Strictly speaking, the classical differential geometry is not fully decomposable into axiomatic system and its interpretation. If one will take the book of Kobayashi and Nomizu [Kobayashi:Nomizu:1963], which is standard reference in the field, then he (or she) will see that right from the first page of this book we are involved in the **Set**-theoretical universe. We will show that this engagement comes not from the nature of differential geometry itself, but rather from the historical involvements. As an outcome, we will be able to use many of (constructive) definitions, propositions and proofs from book of Kobayashi and Nomizu, while staying at the same time in the category-theoretical intuitionistic framework.

<sup>14</sup>In fact, as we will see later, it can be done quite satisfactory also in 'all sufficiently good' [Kock:1981] cartesian closed categories, what means such cartesian closed categories which preserve finite colimits.

and local covering in aim to find does such definition (axiomatics) of  $R$  gives an ability to develop vector spaces with bases which can be managed in the same way as the classical ones. In section 2.8 we will use previous developments to introduce the Riemmanian structure on the synthetic manifold, finally constructing the well-defined and well-managable Riemann, Ricci and Einstein tensors as well as curvature scalar, metric, connection and metrical connection.

If  $f : R \rightarrow R$  is any function and  $x \in R$  is fixed, we may consider  $g : D \rightarrow R$  such that  $f(x + d) = g(d)$ . So, by the Kock–Lawvere axiom,

$$\exists! b \in R \quad \forall d \in D \quad g(d) = g(0) + d \cdot b, \quad (39)$$

$$\exists! b \in R \quad \forall d \in D \quad f(x + d) = f(x) + d \cdot b. \quad (40)$$

Because  $b$  depends on  $x$ , we may define  $f'(x) := b$ , and state the **Taylor’s formula**:

$$\forall f \in R^R \quad \forall x \in R \quad \exists! f'(x) \in R \quad \forall d \in D \quad f(x + d) = f(x) + d \cdot f'(x). \quad (41)$$

It means that *every* function on  $R$  is differentiable. Moreover, it means that every function is *smooth*, and this smoothness is very strong, as we even cannot split  $R$  into two parts (this follows straight from the non-decidability of  $R$ ). The following differentiation rules now become true (for  $f, g \in R^R$ ,  $\lambda \in R$ , and  $\text{id}$  being  $f$  such that  $f(x) = x$ ):

$$\begin{aligned} (f + g)' &= f' + g', \\ (\lambda f)' &= \lambda f', \\ (fg)' &= f'g + fg', \\ (f \circ g)' &= (f' \circ g) \cdot g', \\ \text{id}' &= 1, \\ \lambda' &= 0. \end{aligned} \quad (42)$$

**Proof.** Let us prove the third rule. Left hand side of equation states that for every  $d \in D$  there is  $(fg)(x + d) = (fg)(x) + d(fg)'(x)$ , while right hand side gives  $(fg)(x + d) = f(x + d)g(x + d) = f(x)g(x) + df'(x)g(x) + d f(x)g'(x) + d^2 f'(x)g'(x) = f(x)g(x) + d(f'(x)g(x) + f(x)g'(x))$ . Hence, we have  $d(fg)'(x) = d(f'(x)g(x) + f(x)g'(x))$ . To get the result  $(fg)' = f'g + fg'$  we should cancel  $d$  on both sides of equation. We cannot divide both sides by  $d$ , as far as we do not understand what such operation means. However we may *cancel* them, because from the uniqueness of  $b$  in (36) we get that  $d \cdot b_1 = d \cdot b_2$  for every  $d \in D$ , hence  $b_1 = b_2$ . The proof of fourth rule is analogous: r.h.s.:  $(f \circ g)(x + d) = (f \circ g)(x) + d(f \circ g)'(x)$ , l.h.s.:  $(f \circ g)(x + d) = f(g(x) + dg'(x)) = f \circ g(x) + dg'(x)(f'g)(x)$ , because  $d \cdot g'(x) \in D$ . Finally, we have  $(f \circ g)' = (f' \circ g) \cdot g'$ .  $\square$

It is easy to prove that for any  $\delta = d_1 + d_2$ , where  $d_1, d_2 \in D$ , we have  $f(x + \delta) = f(x) + \delta f'(x) + \frac{\delta^2}{2!} f''(x)$  (this makes sense only if  $2 \in R$ ), but it is not good definition of higher Taylor series, because this equation should be true for every  $\delta^3 = 0$ , so not only for these  $\delta$ 's for which  $\delta = d_1 + d_2$ . This yields us to define so called **higher-order infinitesimals**:

$$D_k := \{x \in R \mid x^{k+1} = 0\} \subset R, \quad (43)$$

and **nilpotent infinitesimals**:

$$D_\infty := \{x \in R \mid \exists n \in \mathbb{N} \quad x^{n+1} = 0\}, \quad (44)$$

where  $R$  should be a  $\mathbb{Q}$ -algebra (i.e. with  $2, 3, \dots$  invertible in  $R$ ), and  $D_1 = D$ . Using this definition we may naturally extend the Kock–Lawvere axiom and Taylor’s formula:

$$\forall g \in R^{D_k} \quad \exists! b_1, \dots, b_k \in R \quad \forall d \in D_k \quad g(d) = g(0) + \sum_{i=1}^k d^i b_i, \quad (45)$$

$$\forall f \in R^R \quad \forall x \in R \quad \exists! f'(x), \dots, f^{(k)}(x) \quad \forall d \in D_k \quad f(x+d) = f(x) + df'(x) + \dots + \frac{d^k}{k!} f^{(k)}(x). \quad (46)$$

It is easy to generalize the Kock–Lawvere axiom into a vector version:

$$\forall g \in (R^n)^D \quad \exists! (b_1, \dots, b_n) \in R^n \quad \forall d \in D \quad g(d) = g(0) + d \cdot (b_1, \dots, b_n). \quad (47)$$

We may regard  $\vec{b} := (b_1, \dots, b_n)$  as an element of an  $R$ -module. Such  $R$ -module  $V$  which for some  $\vec{b} \in V$  and  $g \in V^D$  (and not necessary  $V \cong R^n$ ) satisfies the given above vector version of Kock–Lawvere axiom is called a **Euclidean  $R$ -module**. If we take any function  $f \in (R^n)^{R^n}$ , such that  $f(\vec{x} + d \cdot \vec{u}) = g(d)$ , we get

$$\forall f \in (R^n)^{R^n} \quad \exists (b_1, \dots, b_n) \in R^n \quad \forall d \in D \quad f(x_1+d \cdot u_1, \dots, x_n+d \cdot u_n) = f(x_1, \dots, x_n) + d \cdot (b_1, \dots, b_n). \quad (48)$$

We can define the **directional derivative**  $\partial_{\vec{u}} f(\vec{x}) := \vec{b} = (b_1, \dots, b_n)$ , and the **partial derivative**  $\partial_i f(\vec{x}) := \frac{\partial}{\partial x_i} f(x_1, \dots, x_n) := \partial f(x_1, \dots, x_n) / \partial x_i := (0, \dots, 0, b_i, 0, \dots, 0)$ .

#### Proposition 2.4

$$\forall \vec{x} \in R^n \quad \forall \lambda, \mu \in R \quad \partial_{\lambda \vec{u} + \mu \vec{v}} f(\vec{x}) = \lambda \partial_{\vec{u}} f(\vec{x}) + \mu \partial_{\vec{v}} f(\vec{x}). \quad (49)$$

**Proof.**  $f(\vec{x}) + d \cdot \partial_{\lambda \vec{u}} f(\vec{x}) = f(\vec{x} + d \cdot \lambda \vec{u}) = f(\vec{x}) + d \cdot \lambda \partial_{\vec{u}} f(\vec{x})$ , so  $\partial_{\lambda \vec{u}} f(\vec{x}) = \lambda \partial_{\vec{u}} f(\vec{x})$ . Next,  $f(\vec{x} + d(\vec{u} + \vec{v})) = f(\vec{x} + d\vec{u}) + d \cdot \partial_{\vec{v}} f(\vec{x} + d\vec{u}) = f(\vec{x}) + d \partial_{\vec{u}} f(\vec{x}) + d \partial_{\vec{v}} f(\vec{x}) + d^2 \partial_{\vec{u}} (\partial_{\vec{v}} f(\vec{x})) = f(\vec{x}) + d \partial_{\vec{u}} f(\vec{x}) + d \partial_{\vec{v}} f(\vec{x})$ , and  $f(\vec{x} + d(\vec{u} + \vec{v})) = f(\vec{x}) + d \partial_{\vec{u} + \vec{v}} f(\vec{x})$ , so  $\partial_{\vec{u} + \vec{v}} f(\vec{x}) = \partial_{\vec{u}} f(\vec{x}) + \partial_{\vec{v}} f(\vec{x})$ .  $\square$

**Definition 2.5** The **differential** of  $f$  with respect to  $\vec{x}$  is a map

$$f'(\vec{x}) = df(\vec{x}) : \vec{u} \mapsto df(\vec{x})(\vec{u}) = \partial_{\vec{u}} f(\vec{x}). \quad (50)$$

Note that we can easily generalize these notions from  $f : R^n \rightarrow R^n$  to  $f : R^n \rightarrow V$ , where  $V$  is some Euclidean  $R$ -module, however it would be in general case rather formal definition. As we see, basic constructions of differential calculus are quite easy. To refuse this feeling, let us state the second ‘problematic’ proposition of SDG.

**Proposition 2.6**  $D$  is not an ideal of  $R$ .

**Proof.** Let  $d_1, d_2 \in D$ . We have  $(d_1 + d_2)^2 = d_1^2 + d_2^2 + 2d_1d_2$ . If  $D$  is an ideal of  $R$ , then  $d_1 + d_2 \in D$ , hence  $2d_1d_2 = 0$ , and so  $d_1d_2 = 0$ . This means that  $\forall d_1 \in D \quad d_2 = 0$ , hence  $D = \{0\}$ , what is in contradiction with the Kock–Lawvere axiom.  $\square$

For the situation presented above, we have

$$(d_1 + d_2)^2 = d_1^2 + d_2^2 + 2d_1d_2, \quad \text{so} \quad (51)$$

$$d_1 + d_2 \in D \iff d_1 \cdot d_2 = 0. \quad (52)$$

This is a *big* problem: the sum of two infinitesimals may not be an infinitesimal, thus our infinitesimal calculations fall out of the infinitesimal region, and become strongly non-managable! To solve this problem, we may define new types of infinitesimal objects, like

$$D \vee D := D(2) := \{(d_1, d_2) \in R^2 \mid \forall d_1, d_2 \in D \quad d_1 \cdot d_2 = 0\} = \{(d_1, d_2) \in R^2 \mid \forall d_1, d_2 \in D \quad d_1 + d_2 \in D\} \quad (53)$$

and

$$D(n) := \{(d_1, \dots, d_n) \in R^n \mid \forall i, j \in \{1, \dots, n\} \forall d_i, d_j \in D \ d_i \cdot d_j = 0\}, \quad (54)$$

but  $D(n) \neq D \times \dots \times D$  and  $D(2) \neq D \times D$ , because  $D$  is not an ideal of  $R$ . This raises the question: is it reasonable to use infinitesimals if they seem to have so complicated properties? These problems may be solved by introduction of the more general definition of infinitesimal objects, and asserting the generalized version of Kock–Lawvere axiom. From the latter immediately will follow the proposition saying that, although  $D$  is not an ideal of  $R$ , it looks like an ‘effective ideal’ from the point of view of  $R$ , so the operations like

$$D \times D \xrightarrow{+} D_2 : (d_1, d_2) \mapsto d_1 + d_2, \quad \text{or} \quad (55)$$

$$D \times D \xrightarrow{\cdot} D : (d_1, d_2) \mapsto d_1 \cdot d_2 \quad (56)$$

are ‘thought by  $R$ ’ (strictly speaking, by functions on  $R$ ) to be surjective. As the final result of those generalizations, we will receive the notion of *microlinear space* (or object), which will have all properties needed for development of the differential geometry in synthetic context. Let us begin with reformulating the Kock–Lawvere axiom in terms of cartesian closed categories.

**Kock–Lawvere axiom v. 2** *The map  $R \times R \xrightarrow{\alpha} R^D$  given by  $(a, b) \mapsto [d \mapsto a + db]$  is invertible.*

If we will define the multiplication on  $R \times R$  such that

$$(a_1, b_1) \cdot (a_2, b_2) := (a_1 \cdot a_2, a_1 \cdot b_2 + a_2 \cdot b_1), \quad (57)$$

this will make  $R \times R$  into  $R$ -algebra (denoted as  $R[\varepsilon]$ ), and  $\alpha$  into  $R$ -algebra homomorphism, because of  $[d \mapsto a_1 + db_1] \cdot [d \mapsto a_2 + db_2] := [d \mapsto (a_1 + db_1)(a_2 + db_2)] = [d \mapsto a_1 a_2 + d(a_1 b_2 + a_2 b_1)]$ . So we may now express the Kock–Lawvere axiom one more time, as an isomorphism of  $R$ -algebras.

**Kock–Lawvere axiom v. 3** *The map  $R \times R \xrightarrow{\alpha} R^D$  given by  $(a, b) \mapsto [d \mapsto a + db]$  is an  $R$ -algebra isomorphism  $R[\varepsilon] \xrightarrow{\cong} R^D$ .*

We would like to make such generalization of this axiom to include those situations, when we deal not with  $R \times R$ , but with  $R \times \dots \times R$ . This is motivated by wish of succesful handling objects like  $D(n) \subset D \times \dots \times D$ . As we see, these different types of infinitesimals share the common property of being defined by the annihilation of some polynomials. Me may try to isolate these polynomials by concerning them as some ideal, and divide our  $R$ -algebra by this ideal.

**Definition 2.7** *Let  $R[X_1, \dots, X_n]$  be a commutative ring with  $n$  generators  $X_1, \dots, X_n$ . Let  $p_1(X_1, \dots, X_n), \dots, p_m(X_1, \dots, X_n)$  be the polynomials with coefficients from  $R$ , and let  $I$  be the ideal generated by these polynomials. A **finitely presented  $R$ -algebra** is an  $R$ -algebra*

$$R[X_1, \dots, X_n]/I \equiv R[X_1, \dots, X_n]/(p_1(X_1, \dots, X_n), \dots, p_m(X_1, \dots, X_n)). \quad (58)$$

**Definition 2.8** *Let  $\mathcal{E}$  be some cartesian closed category, and let  $A \in \text{Ob}(\mathcal{E})$  be an  $R$ -algebra. The **spectrum**  $\text{Spec}_A(R[X_1, \dots, X_n]/I)$  of finitely presented  $R$ -algebra  $R[X_1, \dots, X_n]/I$  is a subobject (‘subset’, naively speaking) of  $A^n$ , which consists of elements in  $A^n$  annihilating the polynomials in  $I$ .*

**Examples**



1.  $\text{Spec}_R(R[X]) = R$ ,
2.  $\text{Spec}_R(R[X]/(X^2)) = \text{Spec}_R(R[\varepsilon]) = \{d \in R \mid d^2 = 0\}$ ,
3.  $\text{Spec}_{R \times R}(R[X, Y]/(X^2 + Y^2 - 1)) = \{(x, y) \in R \times R \mid x^2 + y^2 - 1 = 0\}$ .

By an analogy with (57), we may define now a more general way of making  $R \times \dots \times R = R^n$  into  $R$ -algebra.

**Definition 2.9** A **Weil algebra** over  $R$  is an  $R$ -algebra  $W$  (denoted sometimes as  $R \otimes W$ ) such that:

1. There is a  $R$ -bilinear multiplication map  $\mu : R^n \times R^n \rightarrow R^n$ , making  $R^n$  into a commutative  $R$ -algebra with  $(1, 0, \dots, 0)$  as a multiplication unit.
2. The object (‘set’)  $I$  of elements in  $R^n$  with first coordinate equal zero is a nilpotent ideal.
3. There is an  $R$ -algebra map  $\pi : W \rightarrow R$  given by  $(x_1, \dots, x_n) \mapsto x_1$ , called the **augmentation**. (Its kernel is  $I$ , and it’s called an **ideal of augmentation**.)

The homomorphism of Weil algebras sends ideal  $I_1$  of augmentation of  $W_1$  into the ideal  $I_2$  of augmentation of  $W_2$ , so the diagram

$$\begin{array}{ccc} W_1 & \longrightarrow & W_2 \\ & \searrow \pi_1 & \swarrow \pi_2 \\ & & R \end{array} \quad (59)$$

commutes. For example,  $R$  and  $R[\varepsilon]$  are Weil algebras. Moreover, it is easy to see, that each Weil algebra is a finitely presented  $R$ -algebra.

**Definition 2.10** If  $W$  is some Weil algebra object, then objects  $D(W) := \text{Spec}_R(W)$  are called the **(formal) infinitesimals** or **small objects** (of  $R$ ).

Hence, for Weil algebra  $W$  with a finite presentation  $R[X_1, \dots, X_n]/(p_1(X_1, \dots, X_n), \dots, p_m(X_1, \dots, X_n))$  we have  $D(W) = \text{Spec}_R(W) = \{(d_1, \dots, d_n) \in R^n \mid p_1(d_1, \dots, d_n) = \dots = p_m(d_1, \dots, d_n) = 0\}$ . Similarly to Kock–Lawvere axiom v.2 we can define an  $R$ -algebra homomorphism  $\alpha : R[X_1, \dots, X_n] \rightarrow R^{D(W)}$  by  $\alpha(p_i)(d_1, \dots, d_n) = p_i(d_1, \dots, d_n)$ . This homomorphism naturally promotes  $R[X_1, \dots, X_n]$  to Weil algebra  $W \simeq R[X_1, \dots, X_n]/I$ , because  $(d_1, \dots, d_n)$  annihilate the polynomials of  $I$ , so  $W \xrightarrow{\alpha} R^{D(W)}$  is an  $R$ -algebra homomorphism, which is natural in the sense that we have the commutative diagram

$$\begin{array}{ccc} W_1 & \xrightarrow{\alpha_1} & R^{D(W_1)} \\ f \downarrow & & \downarrow R^{D(f)} \\ W_2 & \xrightarrow{\alpha_2} & R^{D(W_2)}. \end{array} \quad (60)$$

**Kock–Lawvere axiom v. 4 (generalized)** For any Weil algebra  $W$  the  $R$ -algebra homomorphism

$$W \xrightarrow{\alpha} R^{D(W)} = R^{\text{Spec}_R(W)} \quad (61)$$

is an isomorphism.

To understand the meaning of this generalization of Kock–Lawvere axiom, consider a finite diagram  $\mathcal{D}$  in a category of  $R$ -algebras, represented below by  $R_i \xrightarrow{f} R_j$ . The limit of this diagram is such  $\text{Lim } R$  that for every cone on  $\mathcal{D}$  with vertex  $A$  there exists a unique arrow  $A \rightarrow \text{Lim } R$  such that the diagram

$$\begin{array}{ccc}
 & A & \\
 \sigma_i \swarrow & \Downarrow \exists! & \searrow \sigma_j \\
 & \text{Lim } R & \\
 \mu_i \swarrow & & \searrow \mu_j \\
 R_i & \xrightarrow{f} & R_j
 \end{array} \tag{62}$$

commutes. It is (quite) easy to see, that  $\text{Lim } R$  can be expressed as an object (‘set’) such that

$$\text{Lim } R = \{(r_i)_{i \in I} \in \prod_{i \in I} R_i \mid \forall f : R_i \rightarrow R_j \ f(r_i) = r_j\}, \tag{63}$$

where  $I$  is a small category indexing the diagram  $\mathcal{D}$ . Of course,  $\text{Lim } R \subseteq \prod_{i \in I} R_i$  is also an  $R$ -algebra. But if we will take Weil algebras  $W_i$  instead of  $R$ -algebras  $R_i$ , their limit  $\text{Lim } W$  does not have to be Weil algebra (for example, a product  $R^{n+1} \times R^{m+1}$  of two Weil algebras is not a Weil algebra, because its dimension should be  $n + m + 1$ , and not  $n + m + 2$ ). However, we can consider only these  $\text{Lim } W$  which are Weil algebras. When we are speaking about  $R$ -algebras and Weil algebras, we are indeed speaking about two categories:  $\mathbf{R}\text{-Alg}$  and  $\mathbf{W}$ . We also speak about  $\mathbf{R}\text{-Alg}_{\mathbf{FP}}$ , i.e. the (cartesian closed) category of finite presented  $R$ -algebras. Let us also denote our cartesian closed category of intuitionistic ‘sets’ (where belong all these objects like  $D$ ,  $D(2)$  and  $R$ ), as  $\mathcal{E}$ . Now we are able to treat  $\text{Spec}_R(-)$  as a contravariant<sup>15</sup> functor from the category of finite presented  $R$ -algebras to  $\mathcal{E}$ , so  $\text{Spec}_R : (\mathbf{R}\text{-Alg}_{\mathbf{FP}})^{op} \rightarrow \mathcal{E}$ . However, in this situation we want to concern only the restriction of domain of this functor to the category of Weil algebras, i.e.  $D := \text{Spec}_R : \mathbf{W}^{op} \rightarrow \mathcal{E}$ , which produces the commutative diagram

$$\begin{array}{ccc}
 & D(\text{Lim } W) & \\
 D(\mu_i) \nearrow & & \nwarrow D(\mu_j) \\
 D(W_i) & \xleftarrow{D(f)} & D(W_j)
 \end{array} \tag{64}$$

Functor  $D$  does not have to preserve limits, so this diagram does not have to be a colimit, although it is a co-cone. Crucial for further development of SDG is assertion when the following commutative diagram obtained by applying the functor  $R^{(-)}$  to (64) is a limit diagram (of  $R$ -algebras):

$$\begin{array}{ccc}
 & R^{D(\text{Lim } W)} & \\
 R^{D(\mu_i)} \nearrow & & \nwarrow R^{D(\mu_j)} \\
 R^{D(W_i)} & \xrightarrow{R^{D(f)}} & R^{D(W_j)}
 \end{array} \tag{65}$$

because exactly then all arithmetic of functions working on infinitesimals will behave properly. It becomes in those situations, when the covariant composition of functors

$$\mathbf{R}\text{-Alg}_{\mathbf{FP}}^{op} \supset \mathbf{W}^{op} \xrightarrow{\text{Spec}_R} \mathcal{E} \xrightarrow{R^{(-)}} \mathcal{E} \tag{66}$$

sends limit diagrams in  $\mathbf{W}$  to limit diagrams in  $\mathcal{E}$ .

<sup>15</sup>It is contravariant, because  $\text{Spec}_R(R[X_1, \dots, X_n]/I)$  is a map  $R[X_1, \dots, X_n]/I \rightarrow R$ , thus  $\text{Spec}_R(R[X_1, \dots, X_n]/I) = \text{Hom}_{\mathbf{R}\text{-Alg}}(R[X_1, \dots, X_n]/I, R)$ , so  $\text{Spec}_R(-) \subset \text{Hom}_{\mathbf{R}\text{-Alg}}(-, R)$ .

**Definition 2.11** Let  $\mathcal{D}$  be a finite inverse diagram (co-cone) of infinitesimal spaces (objects, ‘sets’) obtained by applying a functor  $D = \text{Spec}_R$  to some finite limit diagram of Weil algebras (with vertex which also is a Weil algebra), and send by  $R^{(-)}$  into a limit diagram. An object  $M$  is called the **microlinear space** if the functor  $M^{(-)}$  sends every  $\mathcal{D}$  into a limit diagram, and we say that  $M$  **perceives**  $\mathcal{D}$  as a colimit diagram. Such  $\mathcal{D}$  are sometimes called the **quasi-colimits**.

**Corollary 2.12** If  $M$  is microlinear object and  $X$  is any object, then  $M^X$  is microlinear. Any finite limit of microlinear objects is microlinear.  $R$  and its finite limits as well as exponentials are microlinear. Any infinitesimal **affine scheme**  $\text{Spec}_R(\text{Lim } W)$  is microlinear.

The main technique of proof in SDG is to show that some diagrams of small objects are perceived as colimits. These proofs are given constructively, to fit the requirements of intuitionistic logic and Kock-Lawvere axiom. The situation of perceiving of co-cones of infinitesimals by microlinear spaces in SDG corresponds to standard procedure of leaving infinitesimally small values of higher order as ‘equal’ to zero in classical differential geometry. The difference between these two theories is now more clear in this perspective: classical differential geometry handles, rather ‘intuitively’ than formally, infinitesimally small values, using only these orders which lead to proper results. SDG does it formally and publicly on the algebraic and categorical grounds, what leads to necessity of incorporation of ‘intuitiveness’ into formalism – and this is the rabbit’s hole from where the intuitionism jumps out. It will be shown that microlinear space is a synthetic equivalent of well-known classical notion of manifold. However, strictly speaking, the synthetic equivalent of classical differentiable manifold is a *formal manifold*, which is a microlinear space with families of coverings with coordinate charts (see section 2.7). The clue is that in SDG we *do not have to* introduce the coordinates and local covering to construct the geometrical objects.

### 3 Vector bundles

We have made a passage from the Kock-Lawvere axiom formulated in terms of the commutative ring  $R$  and the object of infinitesimals  $D$  to a more general form using the Weil algebras. Next we have defined the notion of the microlinear object (space), which satisfies the generalized version of Kock-Lawvere axiom in the same way as  $R$  satisfies the first version of it<sup>16</sup>. In this section, using the properties of the microlinear space, we will define tangent and vector bundles, vector fields, Lie bracket and Lie derivative.

Any curve on a space  $M$  may be regarded as an element  $k$  of  $M$  parametrized by an  $I$ , i.e.  $k : I \rightarrow M$ . It means that  $k \in M^I$ .

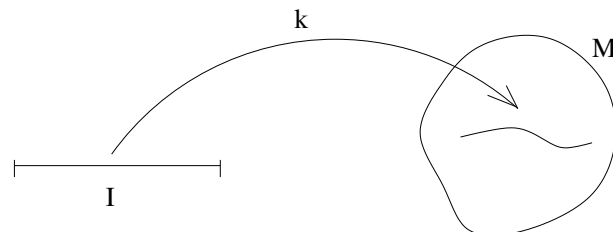

By an analogy, to generate a space tangent to the space  $M$  in some point  $x$ , we should take an element  $t$  of  $M$  parametrized by an infinitesimal piece of line  $D$ , called the **infinitesimal** or the **generic tangent vector**.

<sup>16</sup>To be precise, one should say that  $R$  (and not  $M$ ) satisfies the generalized Kock-Lawvere axiom, but there is given the correspondence between such  $R$  and microlinear space  $M$ , thus we may use such phrase by abuse.

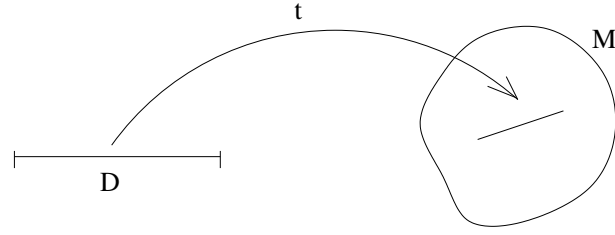

It means that  $t : D \rightarrow M$  or  $t \in M^D$  and  $t(0) = x$ .

**Definition 3.1** A *tangent vector* (or just *tangent*) to a microlinear space  $M$  with **base point** (or **attached at**)  $x$  is a map  $t : D \rightarrow M$  (i.e. the element of exponential object,  $t \in M^D$ ) such that  $x = t(0)$ . A **tangent bundle** is an object  $M^D$  together with a map  $\pi : M^D \rightarrow M$  sending each tangent vector  $t \in M^D$  to its base point  $\pi(t) = t(0) = x$ . The set of tangent vectors with base point  $x$  is called the **tangent space** to  $M$  at  $x$  and denoted  $M_x^D$ . We define the notation  $TM := M^D$  and  $T_xM := M_x^D$ .

**Definition 3.2** Consider some object  $E$ , the microlinear object  $M$ , the element  $x \in M$  and the arrow  $p : E \rightarrow M$ . We call a **fibre** of  $p$  at  $x$  the arrow  $p_x := p^{-1}(x)$ . The **vector bundle** over  $M$  is a such  $p$  that for every  $x$  the  $p_x$  is an  $R$ -module that satisfies the Kock-Lawvere axiom (thus, it is an Euclidean  $R$ -module), i.e. the map  $\alpha : p_x \times p_x \rightarrow (p_x)^D$  such that  $\alpha(u, v)(d) = u + d \cdot v$  is a bijection. Such  $p_x$  is called the **vector space**. The **section** of  $p$  is a map  $s : M \rightarrow E$  such that  $p \circ s = \text{id}_M$ , i.e.  $p(s(x)) = x$  for all  $x \in M$ .

**Proposition 3.3** The tangent bundle is a vector bundle.

**Proof.** We should prove that 1)  $T_xM$  has an  $R$ -module structure, 2)  $T_xM$  is an (Euclidean) vector space for every  $x$  (i.e. it satisfies the vector version of the Kock-Lawvere axiom).

1. We will prove that the map  $\pi : M^D \rightarrow M$ , such that  $\tau(t) = t(0) = x$  for  $t \in M^D$  and  $t(0) = x \in M$ , has an  $R$ -module structure. For  $M = R$ , using the first version of Kock-Lawvere axiom, we can write

$$\begin{cases} \forall d \in D & t_1(d) = x + d \cdot a_1, \\ \forall d \in D & t_2(d) = x + d \cdot a_2, \end{cases} \quad (67)$$

and define

$$\begin{aligned} \forall d \in D & (t_1 + t_2)(d) := x + d \cdot (a_1 + a_2), \\ \forall d \in D & 0(d) := x, \\ \forall d \in D & \alpha \cdot t_1(d) := x + d \cdot \alpha a_1. \end{aligned} \quad (68)$$

For general  $M$  the second definition does not change. Third can be rewritten as  $\forall d \in D \quad \alpha t(d) = t(\alpha d)$ . The problem is that for  $M \neq R$  the first definition is generally not proper, as it makes use of the ring structure of  $R$ . However,  $M$  by definition is microlinear space, so it perceives co-cones of small objects as colimits, e.g. the diagram

$$\begin{array}{ccc} 1 & \xrightarrow{0} & D \\ 0 \downarrow & & \downarrow i_2 \\ D & \xrightarrow{i_1} & D(2) \end{array} \quad (69)$$

is send by  $M$  to the limit (pullback) diagram

$$\begin{array}{ccc}
 M & \xleftarrow{M^0} & M^D \\
 M^0 \uparrow & & \uparrow M^{i_2} \\
 M^D & \xleftarrow{M^{i_1}} & M^{D(2)},
 \end{array} \tag{70}$$

if it is send by  $R$  to pullback diagram, what should be proven first, and it will be done now. Let  $f, g : D \rightarrow R$ , and let  $i_1, i_2$  be the canonical injections  $i_1(d) = (d, 0)$  and  $i_2(d) = (0, d)$ . We put  $f(0) = g(0) = a$ , so  $f(d) = a + db$  and  $g(d) = a + d'b'$ . We define  $h : D(2) \rightarrow R$  such that  $h(d_1, d_2) = a + bd_1 + b'd_2$ , hence  $h(i_1(d)) = f(d)$  and  $h(i_2(d)) = g(d)$ . Such  $h$  is a pullback of  $f$  and  $g$  over  $R$  if it is unique. Let's take then some other morphism  $k : D(2) \rightarrow R$  such that  $k \circ i_1 = f$  and  $k \circ i_2 = g$ . Then  $k(d_1, d_2) = a' + b_1d_1 + b_2d_2$  and so  $k(0, 0) = a'$ , thus  $a' = a$ . We have  $k(d, 0) = b_1d$  and  $k(0, d) = b_2d$ , thus we get  $b_1 = b$  and  $b_2 = b$ , hence  $k = h$ , so  $h$  is unique and the diagram

$$\begin{array}{ccccc}
 k \in R^{D(2)} & & & & \\
 \downarrow R^{k \circ i_1} & & & & \\
 h \in R^{D(2)} & \xrightarrow{R^{i_1}} & R^D \ni f & & \\
 \downarrow R^{i_2} & & \downarrow R^0 & & \\
 g \in R^D & \xrightarrow{R^0} & R & & 
 \end{array} \tag{71}$$

is a pullback, so (70), by the microlinearity of  $M$ , is a pullback too. Consider now  $t_1, t_2 \in M^D$  and  $\chi_{t_1, t_2} \in M^{D(2)}$ . The pullback

$$\begin{array}{ccc}
 \chi_{t_1, t_2} \in M^{D(2)} & \longrightarrow & M^D \ni t_1 \\
 \downarrow & & \downarrow \\
 t_2 \in M^D & \longrightarrow & M
 \end{array} \tag{72}$$

means that there exists a unique mapping  $\chi_{t_1, t_2} : D(2) \rightarrow M$  factorizable on  $t_1$  and  $t_2$ . We may define now  $t_1 + t_2 : D \rightarrow M$  as

$$(t_1 + t_2)(d) := \chi_{t_1, t_2}(d, d). \tag{73}$$

We should prove that such defined  $(t_1 + t_2)(d)$  is associative. Considering the diagram

$$\begin{array}{ccccc}
 & & D & & \\
 & & \uparrow & & \\
 & & D(2) & & \\
 & & \uparrow & & \\
 1 & \xrightarrow{0} & D & & D(3) \\
 & & \uparrow & & \uparrow \\
 & & D(2) & & \\
 & & \uparrow & & \\
 & & D & & 
 \end{array} \tag{74}$$

with

$$\begin{aligned} i_1(d) &:= (d, 0), \\ i_2(d) &:= (0, d), \\ j_{12}(d_1, d_2) &:= (d_1, d_2, 0), \\ j_{23}(d_1, d_2) &:= (0, d_1, d_2), \end{aligned} \tag{75}$$

we may say that it is send by  $R$  to a ‘multi-pullback’ limit diagram, and so, due to micro-linearity of  $M$ , there exists a limit diagram analogous to (72), with  $\chi_{t_1, t_2, t_3} : D(3) \rightarrow M$ , which factorizes as

$$\begin{aligned} \chi_{t_1, t_2, t_3}(d, 0, 0) &= t_1(d), \\ \chi_{t_1, t_2, t_3}(0, d, 0) &= t_2(d), \\ \chi_{t_1, t_2, t_3}(0, 0, d) &= t_3(d). \end{aligned} \tag{76}$$

By the definition (73) we have  $\chi_{t_1, t_2, t_3}(d, d, 0) = (t_1 + t_2)(d)$ , so  $\chi_{t_1, t_2, t_3}(d, d, d) = (t_1 + t_2)(d) + t_3(d) = ((t_1 + t_2) + t_3)(d)$ . Considering the path in the limit diagram which corresponds to  $j_{23}$  in (74), we get  $\chi_{t_1, t_2, t_3}(d, d, d) = t_1(d) + (t_2 + t_3)(d) = (t_1 + (t_2 + t_3))(d)$ . Thus,  $(t_1 + t_2) + t_3 = t_1 + (t_2 + t_3)$ .

2. Now we will prove that all tangent spaces of microlinear space  $M$  satisfy the Kock-Lawvere axiom, i.e.

$$\forall \phi \in (T_x M)^D \quad \exists! t \in T_x M \quad \forall d \in D \quad \phi(d) = \phi(0) + d \cdot t, \tag{77}$$

or, alternatively speaking, the homomorphism  $T_x M \times T_x M \xrightarrow{\alpha} (T_x M)^D$  such that  $\alpha(u, v) = u + d \cdot v$  is a bijection for every  $x \in M$ . Consider  $\phi \in (T_x M)^D$  and let  $u = \phi(0)$ . We can define such  $\tau \in M^{D \times D}$  that  $\tau(d_1, d_2) := (\phi(d_1))(d_2)$ . We should prove that  $\exists! t \in T_x M$   $\phi(d) - \phi(0) = d \cdot t$ , but we may substitute  $\phi(d)$  in  $T_x M$  by  $\phi(d) - \phi(0)$ , treating here  $\phi(0)$  as null vector. If the diagram

$$D \times D \begin{array}{c} \xrightarrow{i_1} \\ \xrightarrow{i_2} \end{array} D \times D \xrightarrow{\cdot} D \tag{78}$$

with  $i_1(d_1, d_2) := (d_1, 0)$  and  $i_2(d_1, d_2) := (0, d_2)$  is perceived by  $R$  as a coequalizer, then it is send to an equalizer diagram by  $M$ , because  $M$  is microlinear. In such situation, for  $\tau \circ i_1 = \tau \circ i_2$  there exists a unique  $t \in T_x M$  such that

$$\tau(d_1, d_2) = t(d_1 \cdot d_2) = (d_1 \cdot v)(d), \tag{79}$$

thus  $\phi(d_1)(d_2) = (d_2 t)(d_2)$  and so  $\phi(d_1) = d_1 t$ . It rests to prove, that (78) is perceived by  $R$  as coequalizer. It will be done in the proof of the proposition 3.9.

□

Now we will prove one very useful proposition.

**Proposition 3.4** *Maps of Euclidean  $R$ -modules are linear if they are homogeneous.*

**Proof.** Let’s take some homogeneous  $F : V \rightarrow W$ , where  $V$  and  $W$  are microlinear spaces. We can take two maps  $\phi(d_1, d_2) := F(d_1 v + d_2 u)$  and  $\psi(d_1, d_2) := F(d_1 v) + F(d_2 v)$ . These are the maps  $D(2) \rightarrow V$ , and can be treated similar to  $\chi_{t_1, t_2}$  in the proof of the proposition 3.3. Thus, we may state  $\phi(d, d) = \psi(d, d) = d \cdot (F(v) + F(u)) = d \cdot F(u + v)$ , what implies that  $F(v) + F(u) = F(u + v)$ . □

**Definition 3.5** An *E*-vector field on  $M$  is a section of a vector bundle  $p : E \rightarrow M$ . The object ('set') of *E*-vector fields on  $M$  is denoted as  $\mathcal{X}(E)$  or  $\mathcal{X}(p)$ . The value of a particular vector field  $Y$  on the element  $m \in M$  is denoted as  $Y_m := Y(m)$ . If  $E = M^D$ , i.e. the  $E$  is a tangent bundle  $M^D \xrightarrow{\pi} M$ , we write  $\mathcal{X}(M) := \mathcal{X}(M^D)$  and say "vector field" instead of " $M^D$ -vector field". In such situation  $X_m \in T_m M$ , and we use the notation  $X_m(d) = X(m, d) = X(m)(d) = X(d)(m) = X(d, m) = X_d(m)$ .

Recall that we develop SDG in a cartesian closed category, so

a vector field  $X : M \rightarrow M^D$  with  $X(m)(0) = m$   
 is isomorphic to an infinitesimal flow of  $M$   $X' : D \times M \rightarrow M$  with  $X'(0, m) = m$   
 and is  $\cong$  to an infinitesimal deformation of the identity map of  $M$   $X'' : D \rightarrow M^M$  with  $X''(0) = \text{id}_M$ .

Moreover, we can treat a tangent bundle as the functor  $(-)^D : M \mapsto M^D$ , acting on some space  $M$ . This gives us an ability to concern the tangent bundle of any function space, because in cartesian closed category

$$(Y^D)^A = (Y^A)^D. \quad (80)$$

In particular, we have

$$(M^D)^M = (M^M)^D, \quad (81)$$

so we may consider  $(M^M)_{\text{id}_M}^D \equiv T_{\text{id}_M} M^M$  as a space tangent to  $M^M$  in the point  $\text{id}_M$ .

**Definition 3.6** The *directional derivative* or *Lie derivative* of  $f : M \rightarrow R$  in the direction  $X \in \mathcal{X}(M)$  is the map  $\mathcal{L}_X f \equiv X(f) : M \rightarrow R$  defined as

$$\forall m \in M \quad \exists! \mathcal{L}_X f(m) \quad \forall d \in D \quad f \circ X_m(d) = f(m) + d \cdot \mathcal{L}_X f(m). \quad (82)$$

This definition follows from the Kock-Lawvere axiom, hence such directional derivative satisfies the common derivarion rules, and for  $f, g : M \rightarrow R$ ,  $\lambda \in R$ ,  $X \in \mathcal{X}(M)$  we have:

$$\begin{aligned} X(\lambda \cdot f) &= (\lambda \cdot X)(f) = \lambda(X(f)), \\ X(f + g) &= X(f) + X(g), \\ X(f \cdot g) &= f \cdot X(g) + g \cdot X(f). \quad (\text{Leibniz rule}) \end{aligned} \quad (83)$$

For any vector fields  $X, Y : M \rightarrow M^D$  we can calculate the value of  $(X \circ Y)(f) = X(Y(f))$ :

$$X \circ Y(fg) = X(Y(fg)) = X(gY(f) + f(Y(g))) = X(g)Y(f) + gX(Y(f)) + X(f)Y(g) + fX(Y(g)). \quad (84)$$

Similarly we get

$$Y \circ X(fg) = Y(g)X(f) + gY(X(f)) + Y(f)X(g) + fY(X(g)). \quad (85)$$

Hence, nor  $X \circ Y$  neither  $Y \circ X$  does not hold the Leibniz rule. However, the difference of  $X \circ Y$  and  $Y \circ X$  does:

$$(X \circ Y - Y \circ X)(fg) = g(X \circ Y - Y \circ X)(f) + f(X \circ Y - Y \circ X)(g). \quad (86)$$

We may define the *commutator* of the vector fields  $X$  and  $Y$  as

$$[X, Y] := X \circ Y - Y \circ X, \quad (87)$$

but can we give the meaningful description of an action of this object not on the multiplied pair of functions  $f, g : M \rightarrow R$ , but on the multiplied pair of infinitesimals? In the next movement we will try to give a positive answer on this question.

**Definition 3.7** A *Lie monoid* (a *Lie group*) is a monoid (resp. group) which is a microlinear space.

It means that for any monoid (or group)  $G$  we have the tangent bundle  $G^D \rightarrow G$  and its fiber  $T_e G = G^D$  at the unit element  $e$ , which has the structure of an  $R$ -module (it was earlier proven for any tangent bundle  $M^D \rightarrow M$  of microlinear space  $M$ ). We may put now  $G = M^M$ , and consider the fiber  $T_{\text{id}_M} M^M$  of the tangent bundle  $(M^M)^D \rightarrow M^M$  of microlinear space  $M^M$ , but we will do it later, giving now the definition of the Lie algebra and the Lie bracket on a lower level (then this of microlinear spaces). Note that in the classical differential geometry the set  $\text{Diff}(\mathcal{M})$  of diffeomorphisms of a manifold  $\mathcal{M}$  is not a Lie group. In SDG all diffeomorphisms of the manifold are just the elements of the object  $M^M$ , which is a microlinear space, thus a Lie group.

**Definition 3.8** A unitary module  $U$  over some commutative ring  $K$  with unit is called a *Lie algebra* if it is equipped with bilinear *Lie bracket* operation

$$[-, -] : U \times U \rightarrow U, \quad (88)$$

such that for any  $X, Y, Z \in U$

$$[X, Y] = -[Y, X], \quad (\text{antisymmetry}) \quad (89)$$

$$[X, [Y, Z]] + [Y, [Z, X]] + [Z, [X, Y]] = 0 \quad (\text{Jacobi identity}) \quad (90)$$

**Proposition 3.9** If  $G$  is a Lie monoid, then  $T_e G$  has a unique Lie bracket operation, what means that it forms a unique Lie algebra over  $T_e G$ .

**Proof.**

0. First, we will prove that the diagram

$$\begin{array}{ccc} D & \begin{array}{c} \xrightarrow{i_1} \\ \xrightarrow{i_2} \end{array} & D \times D \xrightarrow{\cdot} D \\ & \searrow & \nearrow \\ & & 0 \end{array} \quad (91)$$

is perceived by  $R$  as (double) coequalizer, i.e. that the diagram

$$\begin{array}{ccc} R^D & \xleftarrow{R} & R^{D \times D} \begin{array}{c} \xleftarrow{R^{i_1}} \\ \xleftarrow{R^{i_2}} \end{array} & R^D \\ & & \searrow & \nearrow \\ & & & R^0 \end{array} \quad (92)$$

is a (double) coequalizer. Consider  $f : D \times D \rightarrow R$  such that for every  $d$  we have  $f(0, 0) = f(0, d) = f(d, 0)$ . Then we have  $f(d_1, d_2) = f(0, 0) + bd_1 + bd_2 + cd_1d_2$ , so, because  $f(0, d) = f(0, 0) + b'd$  and  $f(d, 0) = f(0, 0) + bd$ , there are equations  $b' = b = 0$  and  $f(d_1, d_2) = f(0, 0) + cd_1d_2$ . If we will take now  $g : D \rightarrow R$  such that  $g(d) = f(0, 0) + cd$ , then it is a unique map  $D \rightarrow R$  which holds  $g(d_1 \cdot d_2) = f(d_1, d_2)$ . Hence, (92) is a (double) coequalizer.

1. (Uniqueness.) We may concern the general situation of a commutator of infinitesimal transformations defined as  $\tau : D \times D \rightarrow G$  such that  $\tau(d_1, d_2) = t_2(-d_2) \circ t_1(-d_1) \circ t_2(d_2) \circ t_1(d_1)$ , where  $t_1, t_2 \in T_e G$ . From the microlinearity of  $G$  we have that it perceives the diagram (91) with  $i_1(d) = (d, 0)$  and  $i_2(d) = (0, d)$  as a double coequalizer, thus it satisfies the so-called *property W* (Wraith):



For every  $\tau : D \times D \rightarrow G$  such that  $\tau(d, 0) = \tau(0, d) = \tau(0, 0)$  there exists a unique  $t : D \rightarrow G$  such that  $t(d_1 \cdot d_2) = \tau(d_1, d_2)$  for all  $(d_1, d_2) \in D \times D$ .

The uniqueness of  $[t_1, t_2]$  follows directly from the uniqueness of  $t$ .

2. (Bilinearity.) As homogeneity implies linearity for  $R$ -modules of tangent spaces, it suffices to show that  $[\lambda t_1, t_2] = \lambda[t_1, t_2] = [t_1, \lambda t_2]$ , but this is obvious by the definition.
3. (Antisymmetry.) From the definition of addition in  $T_e G$  we have  $t_1(d) \circ t_2(d) = (t_1 + t_2)(d)$  and  $t(-d) = (-t)(d) = (t(d))^{-1}$ . So  $[t_1, t_2](d_1 \cdot d_2) = [t_1, t_2](-(-d_1) \cdot d_2) = ([t_1, t_2]((-d_1) \cdot d_2))^{-1} = (t_2(-d_2) \circ t_1(d_1) \circ t_2(d_2) \circ t_1(-d_1))^{-1} = t_1(d_1) \circ t_2(-d_2) \circ t_1(-d_1) \circ t_2(d_2) = [t_2, t_1](d_2 \cdot (-d_1)) = (-[t_2, t_1])(d_1 \cdot d_2)$ .
4. (Jacobi identity.) The diagram (69) is perceived by  $R$  as a pullback, so

$$\forall (d_1, d_2) \in D(2) \quad \forall t_1, t_2 \in T_e G \quad t_1(d_1) \circ t_2(d_2) = t_2(d_2) \circ t_1(d_1). \quad (93)$$

We may calculate now the Jacobi identity, denoting  $X := t_1(d_1)$ ,  $Y := t_2(d_2)$ ,  $Z := t_2(d_3)$ ,  $XY := X \circ Y$ , and using the fact that, by the equation above, we may compute only these elements which share some common part. Thus

$$\begin{aligned} & ([t_1, [t_2, t_3]] + [t_2, [t_3, t_1]] + [t_3, [t_1, t_2]])(d_1, d_2, d_3) = \\ &= [t_1, [t_2, t_3]](d_1, d_2, d_3) \circ [t_2, [t_3, t_1]](d_1, d_2, d_3) \circ [t_3, [t_1, t_2]](d_1, d_2, d_3) \\ &= [X, [Y, Z]][Y, [Z, X]][Z, [X, Y]] = \\ &= [Y, Z]^{-1} X^{-1} [Y, Z] X [Z, X]^{-1} Y^{-1} [Z, X] Y [X, Y]^{-1} Z^{-1} [X, Y] Z = \\ &= [Y, Z]^{-1} [Z, X]^{-1} X^{-1} [Y, Z] [X, Y]^{-1} Y^{-1} [Z, X] Y Z^{-1} [X, Y] Z = \\ &= [Y, Z]^{-1} [Z, X]^{-1} X^{-1} [Y, Z] X [X, Y]^{-1} Y^{-1} [Z, X] Z^{-1} Y [X, Y] [Z^{-1}, Y] Z = \\ &= [Z, Y] [X, Z] X^{-1} [Y, Z] X [Y, X] Y^{-1} [Z, X] Z^{-1} Y [X, Y] [Z^{-1}, Y] Z = \\ &= Y^{-1} Z^{-1} Y Z Z^{-1} X^{-1} Z X X^{-1} Z^{-1} Y^{-1} Z Y X X^{-1} Y^{-1} X Y Y^{-1} X^{-1} Z^{-1} X Z Z^{-1} Y Y^{-1} X^{-1} Y X Y^{-1} Z Y Z^{-1} \\ &= e. \end{aligned} \quad (94)$$

□

**Corollary 3.10** *The Lie bracket of two vector fields  $X$  and  $Y$  is the vector field  $[X, Y] : D \rightarrow M^M$  such that*

$$[X, Y](d_1 \cdot d_2) = Y_{-d_2} \circ X_{-d_1} \circ Y_{d_2} \circ X_{d_1}. \quad (95)$$

*It is unique, bilinear, antisymmetric and satisfies the Jacobi identity. For any  $d \in D$  and any  $(d_1, d_2) \in D(2)$  we have  $X_d \circ X_{-d} = \text{id}_M$ ,  $X_{d_1} \circ X_{d_2} = X_{d_1+d_2}$  and  $X_{d_1} \circ Y_{d_2} = Y_{d_2} \circ X_{d_1}$ . Thus, a Lie bracket is a commutator of infinitesimal transformations of an element  $m \in M$  along vector fields  $X$  and  $Y$ , as it is presented on the picture below.*

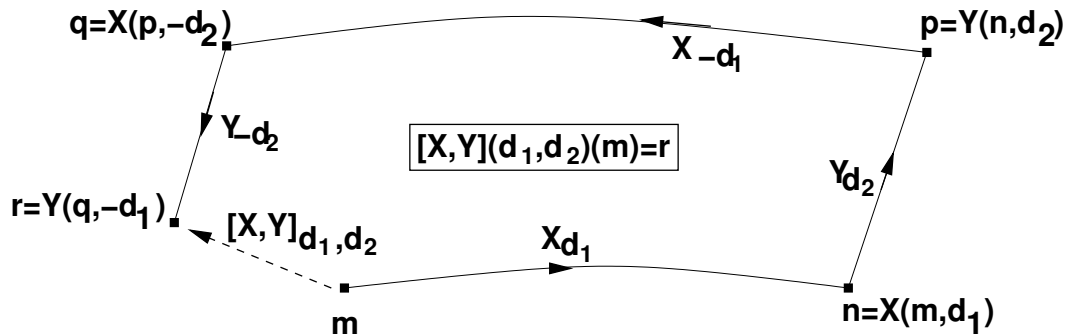

**Proposition 3.11** *For any  $X, Y \in \mathcal{X}(M)$  and  $f \in R^M$ ,*

$$[X, f \cdot Y] = f \cdot [X, Y] + \mathcal{L}_X f \cdot Y. \quad (96)$$

Note that in the situation when commutator acts on functions, it is simple to prove this fact, because  $[X, hY](fg) = X(hY(fg)) - hY(X(fg)) = h(X(Y(fg)) - Y(X(fg))) + Y(fg)X(h) = h[X, Y](fg) + X(h) \cdot Y(fg)$ . The question is, as always, does it work properly with infinitesimals, i.e. with  $(d_1 \cdot d_2) \in D_2$ .

**Proof.** By (95) we have  $[X, fY](d_1, d_2) = (fX)(-d_2) \circ X(-d_1) \circ (fY)(d_2) \circ X(d_1)$ . Following the picture above, we may denote  $n := X(d_1)(m)$ ,  $p := (fY)(d_2)(m)$ ,  $q := X(-d_1)(p)$ . By (82) we get  $d_2 \cdot f(q) = d_2 \cdot f(X_{-d_1}(p)) = d_2(f(p) - d_1 \cdot X(f(p))) = d_2f(n) - d_2d_1X(f(n)) = d_2(f(m) + d_1X(f(m))) - d_1d_2X(f(m)) = d_2f(m)$ , thus  $[X, fY](d_1, d_2) = (fY)(-d_2)(q) = Y_{-d_2f(q)}(q) = Y_{-d_2f(m)}(q) = Y_{-d_2f(m)} \circ X_{-d_1} \circ Y_{d_2f(n)} \circ X_{d_1}(m) = Y_{-d_2f(m)} \circ X_{-d_1} \circ Y_{d_2(f(m)+d_1X(f(m))} \circ X_{d_1}(m) = Y_{-d_2f(m)} \circ X_{-d_1} \circ Y_{d_2f(m)} \circ Y_{d_1d_2X(f(m))} \circ X_{d_1}(m) = Y_{-d_2f(m)} \circ X_{-d_1} \circ Y_{d_2f(m)} \circ X_{d_1}(m) \circ Y_{d_1d_2X(f(m))}(m) = [X, Y]_{d_1d_2f(m)} \circ Y_{d_1d_2X(f(m))}(m) = [X, Y]_{d_1d_2f(Y_{d_1d_2X(f(m))}(m))} \circ Y_{d_1d_2X(f(m))}(m) = f[X, Y](d_1, d_2) \circ Y_{d_1d_2X(f(m))}(m) = f[X, Y](d_1, d_2) \circ X(f)Y(d_1, d_2)(m) = (f[X, Y] + X(f)Y)(d_1, d_2)(m)$ .  $\square$

## 4 Connections

Now we will define an affine connection and a parallel transport. Both of these terms say about transporting a tangent vector  $t_2$  along tangent vector  $t_1$ , hence about completing the cross section of two vectors into a net of parallel cross sections given by the infinitesimal transporting of one vector along another. Our first step will be the definition of these notions on the tangent bundle  $M^D \xrightarrow{\pi} M$ , next we will generalize the notion of an affine connection on any vector bundle  $E \xrightarrow{p} M$ . In the aftermath of this, we will introduce the *covariant derivative*  $\nabla_X Y$  of the  $E$ -vector field  $Y$  along vector field  $X$ . Finally, we will turn back with these notions to the situation when  $E = M^D$ , concerning the affine structure of the microlinear spaces.

We want to define the object maintaining an infinitesimal *connection* between two vector fields tangent to  $M$ , which makes possible to move from the configuration of these fields related to each other (roughly speaking, their cross-section) in one point to the configuration of these fields in other point close to first by an infinitesimal distance. In other words, we want to connect (thus make a mapping from) the cross-section of two tangent bundles (i.e. the pullback  $M^D \times_M M^D$  of two objects  $M^D$  of mappings from infinitesimal line (*microline*)  $D$  to  $M$ , made over microlinear space  $M$ ) over every element of  $M$  to a bundle of cross-sections, i.e. the mapping from a *microsquare*<sup>17</sup>  $D \times D$  to  $M$ . Such map may be thought as an *infinitesimal parallelogram* studied by Elie Cartan [Cartan:1928] as a tool for introducing the torsion and curvature. (In fact, we will follow very tightly his paths, however without introducing the coordinates.) We intend it to be linear, as it should preserve the linear structure of vector spaces. (In fact, it is enough to impose the homogeneity, as this implies linearity.) So, we have to concern the map

<sup>17</sup>In fact, the name ‘microsquare on  $M$ ’ or ‘**2-tangent**’ is used to call the elements of  $M^{D \times D}$ , i.e. the mappings from  $D \times D$  to  $M$ , or even the elements of  $M^{D \times D} \times (D \times D)$ , i.e. the mappings  $D \times D \rightarrow M$  together with their infinitesimal domain.

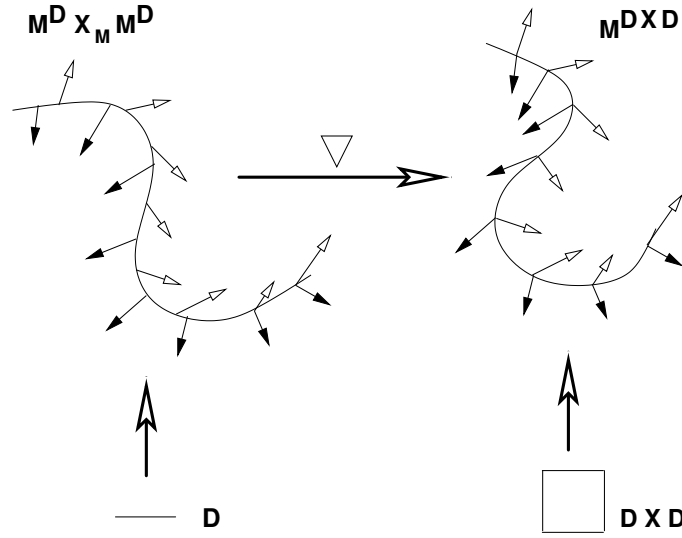

called the *affine connection*  $\nabla$  on a tangent bundle  $\pi : M^D \rightarrow M$ , given by the diagram

$$\begin{array}{ccc}
 M^D & \xleftarrow{\pi_2} & M^D \times_M M^D & \xrightleftharpoons[\begin{smallmatrix} \nabla \\ K \end{smallmatrix}]{\nabla} & M^{D \times D} \cong (M^D)^D \\
 \downarrow & & \downarrow \pi_1 & & \\
 M & \longleftarrow & M^D & & 
 \end{array} \tag{97}$$

where  $K$  is defined as  $(\pi_1 \circ K(\tau))(d) := \tau(d, 0)$  and  $(\pi_2 \circ K(\tau))(d) := \tau(0, d)$ , and  $\tau \in M^{D \times D}$  is a microsquare-tangent-vector. The connection  $\nabla$  is a section of  $K$ , i.e.  $(K \circ \nabla(t_1, t_2))(d_1, d_2) = (t_1(d_1), t_2(d_2))$ . Now we may promote these ideas into a formal definition.

**Definition 4.1** An *affine connection* on tangent bundle  $M^D \rightarrow M$  is the map

$$\nabla : M^D \times_M M^D \rightarrow M^{D \times D}, \tag{98}$$

such that for every  $(t_1, t_2) \in M^D \times_M M^D$ ,  $d_1, d_2 \in D$  and  $\lambda \in R$ ,

1.  $\nabla(t_1, t_2)(d_1, 0) = t_1(d_1)$ ,
2.  $\nabla(t_1, t_2)(0, d_2) = t_2(d_2)$ ,
3.  $\nabla(\lambda \cdot t_1, t_2) = \nabla(t_1, t_2)(\lambda \cdot d_1, d_2)$ ,
4.  $\nabla(t_1, \lambda \cdot t_2)(d_1, d_2) = \nabla(t_1, t_2)(d_1, \lambda \cdot d_2)$ .

Such defined connection is an exact realisation of the original idea of Elie Cartan:

*A manifold with an affine connection is a manifold which, in the immediate neighbourhood of any point, exhibits all the properties of an affine space and on which one has a law relating two such infinitesimally close neighbourhoods.*<sup>18</sup>

**Definition 4.2** An affine connection is called *symmetric* if

$$\nabla(t_1, t_2)(d_1, d_2) = \nabla(t_2, t_1)(d_2, d_1). \tag{99}$$

<sup>18</sup>[Cartan:1955]. (In fact, we have not defined yet the idea of an affine space in a point. But this is easy, because Kock-Lawvere axiom imposes the existence of a local tangent space, as well as local differentiability in any point. We will turn back to the notion of affine space and define it in the next section.)

**Definition 4.3** A *parallel transport*  $p_{(t,h)}^\nabla$  from  $t(0)$  to  $t(h)$  along  $t$  is the map  $p_{(t,h)}^\nabla : T_{t(0)}M \rightarrow T_{t(h)}M$  such that for every  $\lambda \in R$

1.  $p_{(t_1,0)}^\nabla(t_2) = t_2$ ,
2.  $p_{(t_1,h)}^\nabla(\lambda t_2) = \lambda p_{(t_1,h)}^\nabla(t_2)$ ,
3.  $p_{(\lambda t_1,h)}^\nabla(t_2) = p_{(t_1,\lambda h)}^\nabla(t_2)$ .

So the value of  $p_{(t_1,h)}^\nabla(t_2)$  is the result of the transport of the vector  $t_2$  parallelly to itself by an infinitesimal distance  $h$  along the curve given by the vector  $t_1$ . This gives a picture of infinitesimal completing of a cross-section

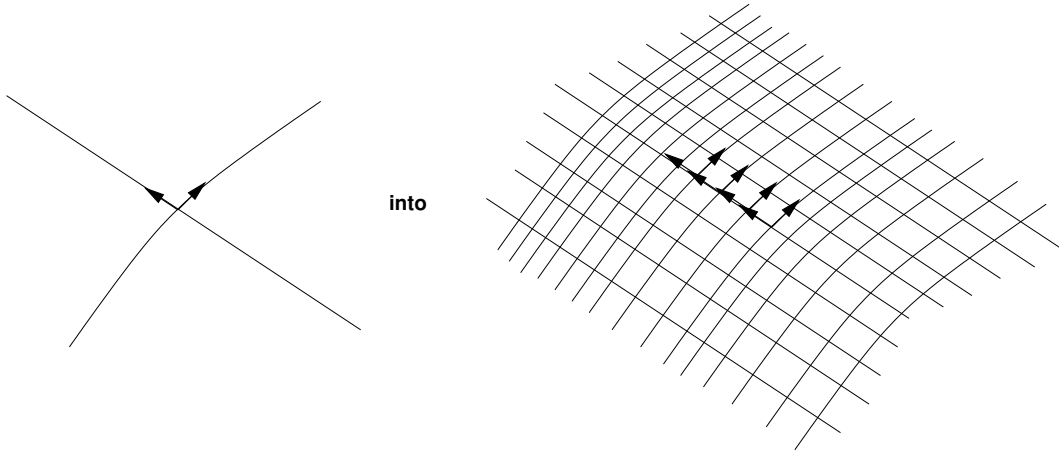

As we see, this picture describes the notion of parallel transport as well as the notion of connection. In fact, they are equal in a precise sense.

**Proposition 4.4** If  $M$  is microlinear, then any affine connection  $\nabla$  on  $M$  gives a parallel transport  $p^\nabla$  on  $M$  given by

$$\nabla(t_1, t_2)(h_1, h_2) = p_{(t_1, h_1)}^\nabla(t_2)(h_2). \quad (100)$$

Conversely, if  $p^\nabla$  is a parallel transport on  $M$ , then the map  $\nabla : M^D \times_M M^D \rightarrow M^{D \times D}$  given by the equation above is an affine connection on  $M$ .

**Proof.** We will prove first that the diagram

$$D \begin{array}{c} \xrightarrow{i_1} \\ \xrightarrow{i_2} \end{array} D \times D \xrightarrow{+} D_2 \quad (101)$$

with  $i_1(d) = (d, 0)$ ,  $i_2(d) = (0, d)$  and  $+: (d_1, d_2) \mapsto d_1 + d_2$  is perceived by  $R$  as a coequalizer. This diagram commutes, because  $d_1 + d_2 = d_2 + d_1$ , so we should prove only the uniqueness. Let  $f : D \times D \rightarrow R$  be such that  $f(d_1, d_2) = a + bd_1 + b'd_2 + cd_1d_2$ . Then  $f(i_1(d)) = a + bd$  and  $f(i_2(d)) = a + b'd$ . By commutativity, we have  $f(i_1(d)) = f(i_2(d))$ , thus  $b = b'$ . For the function  $g : D_2 \rightarrow R$  such that  $g(\delta) = a + b\delta + \frac{c}{2}\delta^2$  we get  $g(d_1 + d_2) = a + b(d_1 + d_2) + \frac{c}{2}(d_1 + d_2)^2 = f(d_1 + d_2)$ , hence  $g$  is the unique map such that  $f(d_1 + d_2) = g(d_1 + d_2)$ , and so (101) is perceived by  $R$  as a coequalizer. Now we can turn back to the main subject of this proof. If  $\nabla$  is an affine connection on  $M$  then for  $t \in T_xM$  and for every  $h \in D$  we have the map

$$T_xM \xrightarrow{p_{(t,h)}^\nabla} T_{t(h)}M, \quad (102)$$

given by (100). We will prove that this map is a bijection. Consider  $\sigma(t) : D_2 \rightarrow M$  given by  $\sigma(t)(d_1 + d_2) = \nabla(t, t)(d_1, d_2)$ , which is properly defined, because  $M$  by the microlinearity and the proof above perceives (101) as coequalizer and, by definition of  $\nabla$ ,  $t(d) = \nabla(t, t)(d, 0) = \nabla(t, t)(0, d)$ . Thus, we can say that for  $d \in D$

$$[d \mapsto \sigma(t)(h + d)] \in T_{t(h)}M. \tag{103}$$

The bijection will be shown by proving that the inverse arrow of  $p_{(t,h)}^\nabla$  is  $p_{(d \rightarrow \sigma(t)(h+d), -h)}^\nabla$ , hence that

$$\begin{cases} p_{(d \rightarrow \sigma(t)(h+d), -h)}^\nabla(p_{(t,h)}^\nabla(s)) = s, \\ p_{(t,h)}^\nabla(p_{(d \rightarrow \sigma(t)(h+d), -h)}^\nabla(s')) = s'. \end{cases} \tag{104}$$

Considering the diagram (69) perceived by  $M$  as a coequalizer, for  $(h_1, h_2) \in D(2)$  we get

$$p_{(t, h_1+h_2)}^\nabla(s) = p_{(d \rightarrow \sigma(t)(h_1+d), h_2)}^\nabla \circ p_{(t, h_2)}^\nabla(s). \tag{105}$$

For  $h = h_1 = -h_2$  we get the first equation. Substituting  $s$  by  $p_{(d \rightarrow \sigma(t)(h+d), -h)}^\nabla(s')$  in the first equation, we get the second equation.  $\square$

If we want to transport the vectors of some vector (not necessary tangent) bundle  $E \rightarrow M$  ‘parallelly’ along the microlinear space, we have to define, what such parallelism means. It seems to be natural answer, that the ‘parallelness’ of vectors in a vector bundle should be given in the terms of this bundle somehow independently from the possible different structures of microlinear spaces on which we may project our bundle of vector spaces. Thus we should concern  $E^D$ , i.e. the tangent space of a space  $E$ , but also we should recall that the ‘transport parallel to microlinear space’ means ‘transport parallel along the vectors of tangent bundle of the microlinear space’.

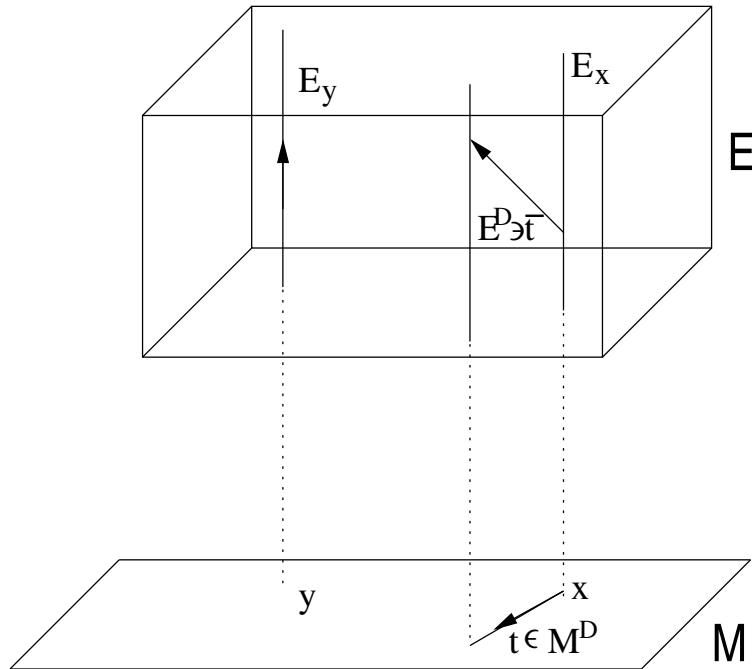

In the concerned earlier situation, the connection between two vectors from tangent bundle  $M^D \rightarrow M$  was defined as a map from the pullback of these spaces over  $M$  to the microsquare  $M^{D \times D} \cong (M^D)^D$ , i.e. to the tangent bundle of the tangent bundle. This leads to corollary, that *parallelism (the connection)* of some vector bundle along tangent space  $M^D$  over the microlinear

space  $M$  is given by the map from the pullback  $E \times_M M^D$  to a tangent space  $E^D$  of this given vector bundle, i.e.

$$E \times_M M^D \xrightarrow{\nabla} E^D \quad (106)$$

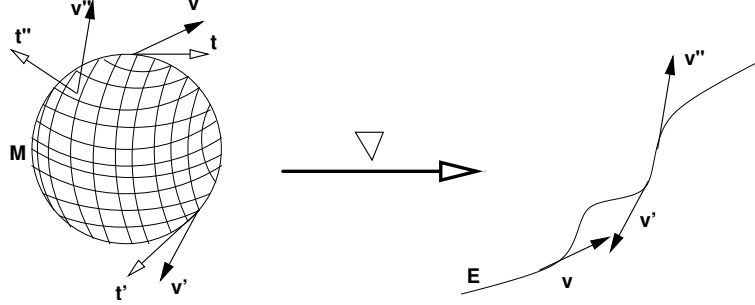

As we want to maintain not only the *parallelness* of vectors given by  $E$ , but also their *lengths* and vector space structure, we must concern that the map  $\nabla$  is linear.

**Definition 4.5** An *affine connection* on a vector bundle  $E \xrightarrow{p} M$  is a map  $\nabla : M^D \times_M E \rightarrow E^D$  such that

1.  $p \circ \nabla(t, v) = t$ , thus  $p \circ \nabla(t, v)(d) = t(d)$ ,
2.  $\nabla(t, v)(0) = v$ ,
3.  $\nabla(\lambda t, v)(d) = \nabla(t, v)(\lambda d) = (\lambda \odot \nabla(t, v))(d)$ ,
4.  $\nabla(t, \lambda v)(d) = (\lambda \nabla(t, v))(d) = \lambda(\nabla(t, v)(d))$ ,

where  $\odot$  denotes the  $R$ -module multiplication in the vector bundle over  $E$ .

To check that such definition is well-established, we will prove first that vector bundle  $p : E \rightarrow M$  together with tangent bundle  $\pi : M^D \rightarrow M$  induces naturally two vector bundle structures on  $M^D \times_M E$ , hence  $\nabla$  is a map of two vector bundles (over  $E$  and over  $M^D$ ).

**Proposition 4.6** 1.  $M^D \times_M E$  is a vector bundle over  $E$  by  $M^D \times_M E \xrightarrow{p_2} E$  and a vector bundle over  $M^D$  by  $M^D \times_M E \xrightarrow{p_1} M^D$ .

2.  $E^D$  is a vector bundle over  $E$  by  $E^D \xrightarrow{\pi} E$  and a vector bundle over  $M^D$  by  $E^D \xrightarrow{p^D} M^D$ .

**Proof.** First let us fix the notation, denoting the  $R$ -module operations in a vector bundle over  $E$  as  $\oplus$  and  $\odot$  for addition and multiplication, respectively. This convention will also hold on next pages.

1. For  $M^D \times_M E$  the tangent bundle over  $E$  is given by

$$\begin{aligned} (t, v) \oplus (t', v) &:= (t \oplus t', v), \\ \lambda \odot (t, v) &:= (\lambda \cdot t, v). \end{aligned} \quad (107)$$

The tangent bundle over  $M^D$  is given by

$$\begin{aligned} (t, v) + (t, v') &:= (t, v + v'), \\ \lambda \cdot (t, v) &:= (t, \lambda \cdot v). \end{aligned} \quad (108)$$

The Kock-Lawvere axiom is satisfied in both situations, because  $M^D \times_M E$  is a pullback of microlinear spaces, thus it is also a microlinear space.

2. The first part is obvious, so we will prove only the second. Consider  $(E^D)_t := (p^D)^{-1}(t)$  and  $E_{t(d)} := p^{-1}(t(d))$ . For  $\phi_d : D \rightarrow E_{t(d)}$  we define  $\phi : D \rightarrow (E^D)_t$  by  $\phi(d')(d) := \phi_d(d')$ . From the vector bundle structure of  $p$  we get

$$\forall u_d \in E_{t(d)} \quad \exists! u_d \in E_{t(d)} \quad \forall d' \in D \quad \phi_d(d') = u_d + d' \cdot v_d. \quad (109)$$

Substituting  $u_d$  by  $u := [d \mapsto u_d]$  and  $v_d$  by  $v := [d \mapsto v_d]$ ,  $u, v \in (E^D)_t$ , we get

$$\forall u \in (E^D)_t \quad \exists! v \in (E^D)_t \quad \forall d' \in D \quad \phi(d') = u + d' \cdot v. \quad (110)$$

So, the Kock-Lawvere axiom is satisfied. The  $R$ -module structure of  $p^D : E^D \rightarrow M^D$  is given by

$$\begin{aligned} (u +_{(E^D)_t} v)(d) &:= u(d) +_{E_{t(d)}} v(d), \\ (\lambda \cdot_{(E^D)_t} v)(d) &:= \lambda \cdot_{E_{t(d)}} (v(d)). \end{aligned} \quad (111)$$

□

Suppose that in some point  $x$  we have got an element of a vector bundle  $v \in E$  and a tangent vector  $t \in M^D$ :

$$(t, v) \in M^D \times_M E. \quad (112)$$

We would like to move the vector  $v$  along the direction given by  $t$  to the new point  $t(d) \in M$ , which is in the infinitesimal distance  $d$  from the point  $t(0) = x \in M$  of the foothold of  $(t, v)$ . In other words, we want to transport  $v$  from the fibre  $E_{t(0)}$  to the fibre  $E_{t(d)}$ . The connection  $\nabla$  is the mapping

$$\begin{array}{ccc} \bar{t} = \nabla(t, v) \in E^D & & \\ \uparrow \nabla & \begin{array}{cc} \xrightarrow{(0)} & \xrightarrow{(d)} \\ \searrow & \searrow \\ \nabla(t, v)(0) = v \in E_{t(0)} & \nabla(t, v)(d) \in E_{t(d)} \end{array} & \\ \downarrow p & & \downarrow p \\ (t, v) \in M^D \times_M E & \begin{array}{cc} \xrightarrow{p \circ \nabla(t, v)(0)} & \xrightarrow{p \circ \nabla(t, v)(d)} \\ t(0) \in M & t(d) \in M \end{array} & \end{array} \quad (113)$$

So, connection  $\nabla : M^D \times_M E \rightarrow E^D$  ‘lifts up’ a pair of vectors from tangent and vector bundle to one vector from  $E^D$ , on which the operation of evaluation of infinitesimal move  $d$  may be performed, to yield a transported vector  $\nabla(t, v)(d)$  placed in the vector space (fibre)  $E_{t(d)}$  over the point  $t(d) \in M$ . It may be represented on the picture

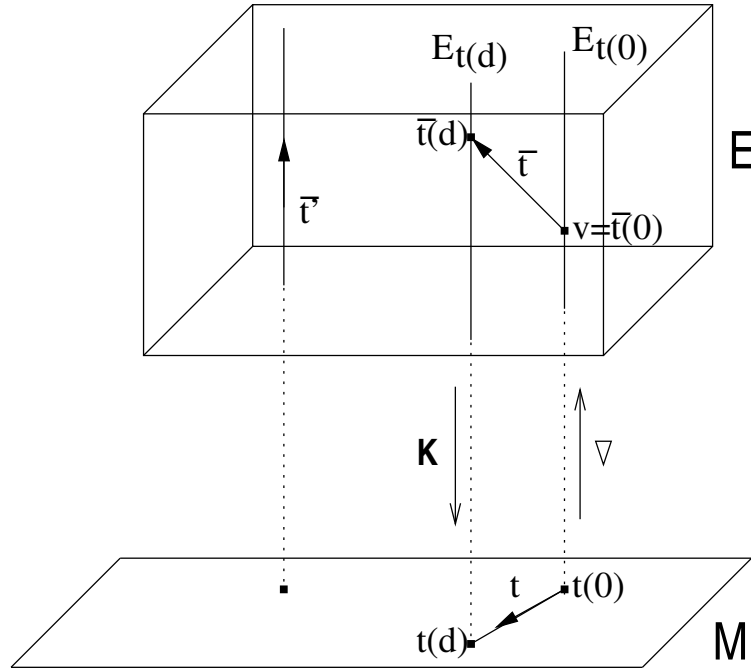

The connection gives for every  $t \in M^D$  footholded in the point  $t(0) \in M$  its ‘image’  $\bar{t}$  in  $E^D$ , footholded in the  $\bar{t}(0) = v \in E$ .<sup>19</sup> Evaluation of  $\bar{t}$  on the infinitesimal  $d$  will give  $\bar{t}(d) \in E$ , the parallel transport of  $v$  along the direction of  $t$ . Conversely, we may think at the beginning about some  $\bar{t} \in E^D$  and consider the map  $K : E^D \rightarrow M^D \times_M E$  such that  $K(\bar{t}) = (p \circ \bar{t}, \bar{t}(0))$ .  $\nabla$  is a section of such  $K$ , because

$$K\nabla(t, v) = (p \circ \nabla(t, v), \nabla(t, v)(0)) = (p \circ \nabla(t, v), v) = (t, v), \quad (114)$$

so  $K\nabla = \text{id}_{M^D \times_M E}$ . There are also such vectors  $\bar{t}$  which projected by  $K$  on  $M^D$  give the null vector (consider  $\bar{t}$  on the picture above). Such  $\bar{t}$  have the property that  $\bar{t}(d) \in E_{p \circ \bar{t}(0)}$ , so  $\bar{t} \in E_{p \circ \bar{t}(0)}^D$ . Hence, we may say that

$$\text{Ker } K = \{\bar{t} | \bar{t} \in E_{p \circ \bar{t}(0)}^D\}, \quad (115)$$

and, by the obvious reason, call them **vertical vectors**. Such vectors cannot be used for the infinitesimal parallel transport given by  $\nabla$ , because are not the image of any  $t \in M^D$  in  $E^D$ . Thus, we may decompose vectors in  $E^D$  into two parts

$$E^D = \text{Ker } K \oplus \text{Im } \nabla =: V(E^D) \oplus H(E^D), \quad (116)$$

where

$$\begin{aligned} V(E^D) &= \text{Ker } K = \{\bar{t} | \bar{t} \in E_{p \circ \bar{t}(0)}^D\} \quad \text{– vertical vectors,} \\ H(E^D) &= \text{Im } \nabla = \{\nabla(t, v) | (t, v) \in M^D \times_M E\} \quad \text{– horizontal vectors.} \end{aligned} \quad (117)$$

The sign  $\oplus$  used above means that  $V(E^D) \rightarrow E$  and  $H(E^D) \rightarrow E$  are **sub-bundles** of a vector bundle  $E^D \rightarrow E$ , and for every  $x \in E$  we may perform an  $R$ -module addition  $V_x \oplus H_x$ . Such sum of the vector sub-bundles is called the **Whitney sum**. So, any vector  $\bar{t} \in E^D$  may be decomposed into the sum

$$\bar{t} = V(\bar{t}) + (V(\bar{t}) - \bar{t}), \quad (118)$$

<sup>19</sup>Note that the directions of arrows  $K$  and  $\nabla$  on the picture above are rather symbolical: in fact,  $\nabla$  is a map  $M^D \times_M E \rightarrow E^D$ , while  $K$  is a map  $E^D \rightarrow M^D \times_M E$ .



where  $V(\bar{t}) \in V(E^D)$  and  $(V(\bar{t}) - \bar{t}) \in H(E^D)$ . We have then

$$V = \text{id}_{E^D} \ominus (\nabla \circ K). \tag{119}$$

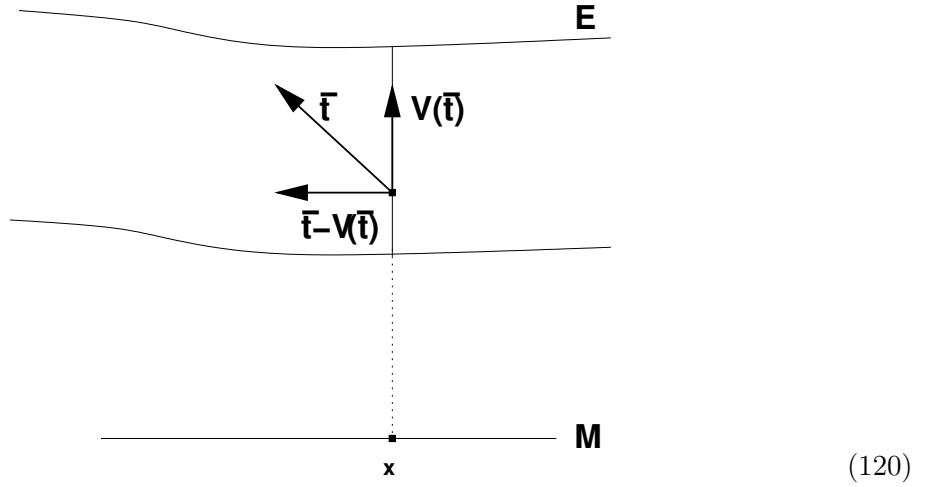

From the Kock-Lawvere axiom, we have  $E \times E \cong E^D$ . Consider now  $(u, v) \in E \times_M E \rightarrow E \times E$ , which is an element of a pullback over  $M$ :

$$\begin{array}{ccc} E \times_M E & \xrightarrow{p_1} & E \\ p_2 \downarrow & & \downarrow p \\ E & \xrightarrow{p} & M, \end{array} \tag{121}$$

and the map  $G : E \times_M E \rightarrow E^D$  given by  $(u, v) \mapsto [d \mapsto u + dv]$ . The element  $u + dv \in E$  is created by the pair  $(u, v)$  of two elements of  $E$  which lay in the same fibre over  $M$  (because  $(u, v) \in E \times_M E$ ). This means that  $\bar{t} = [d \mapsto u + dv]$  is a vertical vector, because  $\bar{t}(d) = u + dv \in E_{p \circ \bar{t}(0)} = E_{p(u)} = E_{p(v)}$ . Hence,

$$\text{Im } G = V(E^D) = \text{Ker } K. \tag{122}$$

This leads to the commutative diagram

$$\begin{array}{ccc} E \times_M E & \xrightarrow{\cong} & V(E^D) = \text{Ker } K \\ \downarrow & & \downarrow \\ E \times E & \xrightarrow[\text{Kock-Lawvere axiom}]{\cong} & E^D = \text{Ker } K \oplus \text{Im } \nabla \end{array} \tag{123}$$

However, to be correct, we should prove that  $G$  and  $K$  are really bilinear as maps of vector bundles.

**Proposition 4.7** 1.  $G$  and  $K$  are both bilinear as maps of vector bundles over  $E$  and over  $M^D$ .

2.  $\text{Im } G = \text{Ker } K$ .

3.  $E \times_M E$  is a vector bundle over  $E$  by  $E \times_M E \xrightarrow{p_1} E$  and a vector bundle over  $M$  by  $E \times_M E \xrightarrow{cm} M$ , where  $cm$  is a canonical map for every fiber  $E_m$  over  $m$ .

**Proof.**

1. The linearity follows from the fact, that  $K$  and  $G$  are the maps of the  $R$ -modules which satisfy the Kock-Lawvere axiom. Such maps are linear if they are homogeneous, and the last is trivial, as  $G(\lambda v) = \lambda G(v)$  and  $K(\lambda v) = \lambda K(v)$ .
2. In fact, we have yet proven that  $\bar{t} \in \text{Im } G \Rightarrow \bar{t} \in \text{Ker } K$ . It suffices to show the converse. Let  $K(\bar{t}) = 0$  for some  $t \in E^D$ . Then  $t \in E_{p \circ \bar{t}(0)}$ , so  $p \circ t$  is constant. By the Kock-Lawvere axiom, we can find the unique  $(u, v)$  such that  $\bar{t} = G(u, v)$ .
3. For the projection  $p_1 : E \times_M E \rightarrow E$  Kock-Lawvere axiom is satisfied by the microlinearity of  $E \times_M E$ . The  $R$ -module structure is given by

$$\begin{aligned} (u, v) \oplus (u', v') &:= (u, v + v'), \\ \lambda \odot (u, v) &:= (u, \lambda \cdot v). \end{aligned} \quad (124)$$

For  $E \times_M E \rightarrow M$  the  $R$ -module structure is given by

$$\begin{aligned} (u, v) + (u', v') &:= (u + u', v + v'), \\ \lambda \cdot (u, v) &:= (\lambda \cdot u, \lambda \cdot v), \end{aligned} \quad (125)$$

and the satisfaction of the Kock-Lawvere axiom is given for every fibre  $E_m$  (for  $m \in M$ ), thus for every fibre product  $E_m \times_M E_m$ .

□

It is good to show the correspondence between  $E \times_M E$  and  $V(E^D)$  on a picture,

where  $\bar{t}(0)$  and  $C(\bar{t})$  are the elements of  $E_{p \circ \bar{t}}$ , and  $V(\bar{t}) = [d \mapsto \bar{t}(0) + d \cdot C(\bar{t})]$ . Thus,  $V$  may be considered as a map  $V : E^D \rightarrow E \times_M E$ , i.e.  $V : \bar{t} \mapsto (\bar{t}(0), C(\bar{t}))$ , while  $G \circ V(\bar{t}) = [d \mapsto \bar{t}(0) + d \cdot C(\bar{t})]$ . So, taking into account (121), we get

$$\begin{aligned} p_1 \circ V &= \pi : E^D \ni \bar{t} \mapsto \bar{t}(0) \in E, \\ p_2 \circ V &= C : E^D \ni \bar{t} \mapsto C(\bar{t}) \in E. \end{aligned} \quad (127)$$

In other words:

$$G \circ \langle \pi, C \rangle = \text{id}_E \oplus \nabla \circ K. \quad (128)$$

$$(129)$$

The ambivalence (or, maybe better to say, undistinguishment) between the transport of  $\bar{t}(0) \in E$  along  $p \circ \bar{t}$  and along  $p \circ (\bar{t} - V(\bar{t}))$  is measured by the  $V(\bar{t}) \in E^D$  or – equivalently – by the  $C(\bar{t}) \in E$ .  $V(\bar{t})$  is unambiguous to  $C(\bar{t})$  in a precise sense of the Kock-Lawvere axiom: as  $V(\bar{t}) = [d \mapsto \bar{t}(0) + dC(\bar{t})]$ ,

$$\forall V(\bar{t}) \in E^D \exists! C(\bar{t}) \in E \quad \forall d \in D \quad V(\bar{t})(d) = \bar{t}(0) + d \cdot C(\bar{t}). \quad (130)$$

Note that from (128) we have  $\bar{t} \ominus \nabla \circ K(\bar{t}) = G(\bar{t}(0), C(\bar{t}))$ , so speaking in terms of  $C$  and  $\nabla$  is equivalent (or, maybe better to say, ‘interchangeable’). A map  $C$  is called the **connection map**, and in the context of classical differential geometry it has appeared in [Dombrowski:1962] and [Patterson:1975]. It may be thought as a map from the ‘space of accelerations’  $E^D$  to the ‘space of velocities’  $E$ . We can also define the map  $\nu : E \rightarrow E^D$  from ‘velocities’ to ‘accelerations’, such that

$$\nu : E \ni u \mapsto [d \mapsto d \cdot u] \in E^D. \quad (131)$$

The given above properties of  $C$  ensure that we have

$$E \xrightarrow{\nu} E^D \xrightarrow{C} E = \text{id}_E. \quad (132)$$

Connection map  $C$  gives an ability to define a parallel transport on a vector bundles.

**Definition 4.8** A **parallel transport**  $p_{(t,d)}$  from  $t(0)$  to  $t(d)$  along  $t$  is the map  $p_{(t,d)} : v \in E_{t(0)} \mapsto \nabla(t, v)(d) \in E_{t(d)}$ . As the connection is linear, this map is bijective and induces the inverse map  $q_{(t,d)} : E_{t(d)} \rightarrow E_{t(0)}$  called the parallel transport from  $t(d)$  to  $t(0)$  along  $t$ . The notation  $p_{(t,d)}^\nabla$  and  $q_{(t,d)}^\nabla$  is sometimes used instead of  $p_{(t,d)}$  and, respectively,  $q_{(t,d)}$ .

**Proposition 4.9**

$$\forall \bar{t} \in E^D \exists! V(\bar{t}) \quad \forall d \in D \quad q_{(p \circ \bar{t}, d)}^\nabla(\bar{t}(d)) = \bar{t}(0) + dC(\bar{t}). \quad (133)$$

**Proof.** Identifying  $q_{(p \circ \bar{t}, d)}^\nabla(\bar{t}(d)) = V(\bar{t})(d)$ , we get the equation (130), satisfied by the virtue of the Kock-Lawvere axiom.  $\square$

The extent, or a ‘gap’, between the vector from vector field (being the section of  $E$ ) and its ‘copy’ transported along some vector field tangent to manifold  $M$  is commonly called **covariant derivative**, and basically may be illustrated by the standard example:

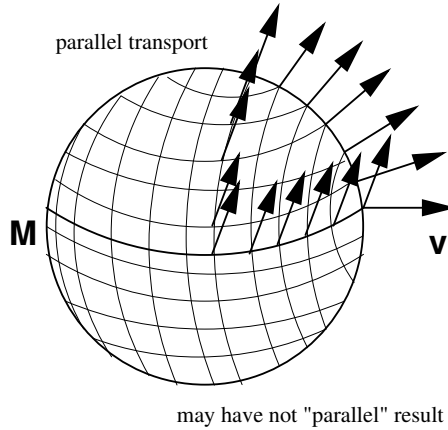

(Note that, in contradiction to earlier pictures, we considered here the elements of  $E$  as vectors.) The covariant derivative is at the same time a generalization of the notion of derivative of a map  $f : R \rightarrow V$ , where  $V$  is a Euclidean  $R$ -module.

**Definition 4.10** Let  $E \rightarrow M$  be a vector bundle,  $X \in \mathcal{X}(M)$ ,  $Y \in \mathcal{X}(E)$ . We have  $M \xrightarrow{X} M^D \xrightarrow{Y^D} E^D$ , and denote  $Y \cdot X := Y^D \circ X : M \rightarrow E^D$ . If  $\nabla$  is an affine connection on  $E$  with connection map  $C$ , the **covariant derivative** of  $Y$  along  $X$  is defined as the  $E$ -vector field

$$\nabla_X Y := C(Y \cdot X) : M \rightarrow E, \tag{134}$$

hence, by (119),

$$\forall d \in D \quad ((Y \cdot X)_m \ominus \nabla(X_m, Y_m))(d) = Y_m + h \cdot (\nabla_X Y)_m. \tag{135}$$

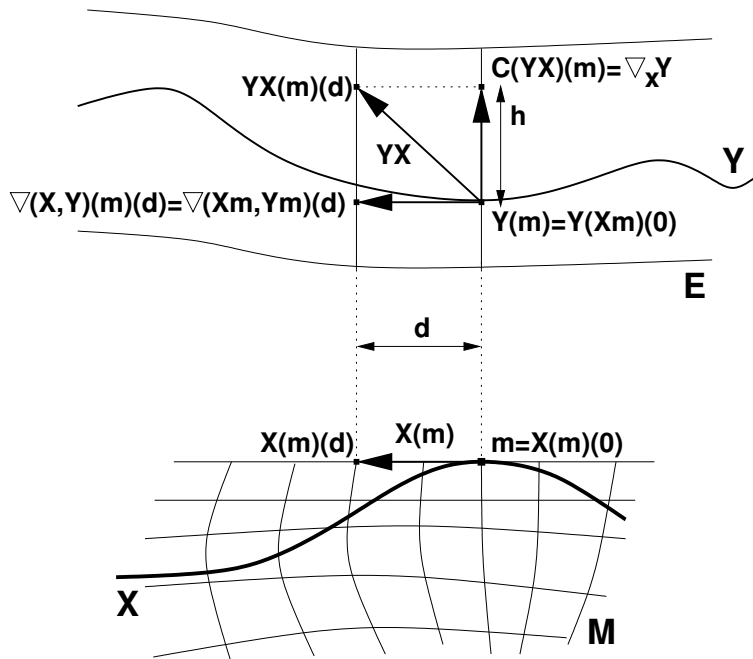

$$(136)$$

**Proposition 4.11** *The covariant derivative  $\nabla_X Y$  is uniquely determined, and it measures the gap in the parallelism between the  $Y_{X_m}$  and  $X_m$ , i.e. the difference between  $Y_{X_m}(d)$  transported back along  $X_m$  and  $Y_m$ .*

**Proof.** The uniqueness is obvious by the equation (135) and the Kock-Lawvere axiom. We should prove now that for every  $d, h \in D$ ,  $m \in M$ ,  $X \in \mathcal{X}(M)$  and  $Y \in \mathcal{X}(E)$ :

$$\nabla(d \mapsto X_{X_m(h)}(d), Y_{X_m(d)})(-h) - Y_m = h \cdot (\nabla_X Y)_m. \quad (137)$$

For  $\phi : D(2) \rightarrow E$  given by  $\phi(d_1, d_2) := \nabla(d \mapsto X_{X_m(d_1)}(d), Y_{X_m(d_1)})(-d_2)$  we have  $\phi(d_1, 0) = (Y \cdot X)_m(d_1)$  and  $\phi(0, d_2) = \nabla(X_m, Y_m)(-d_2)$ , so  $((Y \cdot X)_m \ominus \nabla(X_m, Y_m))(h) = \phi(h, h)$ , thus  $((Y \cdot X)_m \ominus \nabla(X_m, Y_m))(h) = \nabla(d \mapsto X_{X_m(h)}(d), Y_{X_m(h)})(-h)$ .  $\square$

We see, that this proposition and its proof was only another version of proposition 4.9 (while its proof was only another version of the proof of the proposition 4.4).

**Proposition 4.12** *Let  $\nabla$  be an affine connection on a vector bundle  $E \rightarrow M$ . For every  $X, X' \in \mathcal{X}(M)$ ,  $Y, Z \in \mathcal{X}(E)$ ,  $f : M \rightarrow R$ :*

1.  $\nabla_{X+_{M^D} X'} Y = \nabla_X Y + \nabla_{X'} Y$ ,
2.  $\nabla_{f \cdot X} Y = f \cdot \nabla_X Y$ ,
3.  $\nabla_X (Y + Z) = \nabla_X Y + \nabla_X Z$ ,
4.  $\nabla_X (f \cdot Y) = f \cdot \nabla_X Y + \mathcal{L}_X f \cdot Y$ . (Koszul law)

**Proof.**

1.  $(Y \cdot (X +_{M^D} X'))_m = (Y \cdot X)_m \oplus (Y \cdot X')_m$  and the linearity of  $C$ .
2.  $(Y \cdot (fX))_m = f(m) \odot (Y \cdot X)_m$  and the linearity of  $C$ .
3.  $((Y + Z) \cdot X)_m = (Y \cdot X)_m + (Z \cdot X)_m$  and the linearity of  $C$ .
4. We have  $(Y \cdot X)_m \ominus (X_m, Y_m)(h) = Y_m + h(\nabla_X Y)_m$ . Thus for  $t(d) := X_{X_m(h)}(d)$  we can write

$$\nabla(t, Y_{X_m(h)})(-h) = Y_m + h(\nabla_X Y)_m. \quad (138)$$

Substituting  $Y$  by  $f \cdot Y$  we get  $h \cdot (\nabla_X (fY))_m = \nabla(t, f(X_m(h))Y_{X_m(h)})(-h) - f(m)Y_m = \nabla(t, (f(m) + h \cdot X(f)(m))Y_{X_m(h)})(-h) - f(m)Y_m = (f(m) + h \cdot X(f)(m))\nabla(t, Y_{X_m(h)})(-h) - f(m)Y_m = f(m)(\nabla(t, Y_{X_m(h)})(-h) - Y_m) + h \cdot X(f)(m)\nabla(t, Y_{X_m(h)})(-h) = f(m)(Y_m + h \cdot (\nabla_X Y)_m - Y_m) + h \cdot X(f)(m) \cdot (Y_m + h \cdot (\nabla_X Y)_m) = f(m) \cdot h \cdot (\nabla_X Y)_m + h \cdot X(f)(m) \cdot Y_m + 0$ . Cancelling  $h$ 's (by the Kock-Lawvere axiom for  $E_m$ ) we get  $\nabla_X (fX)_m = f(m) \cdot (\nabla_X Y)_m + X(f)(m)Y_m$ .

$\square$

## 5 Affine space

This section is inspired by the wish of giving the strict meaning to Cartan's words:

We say that the manifold is equipped with the “affine connection” if a law relating affine spaces associated with any two infinitesimally close points  $\mathbf{m}$  and  $\mathbf{m}'$  is specified. The choice of this law is quite arbitrary; it only has to enable us to say that such and such point in the affine space associated with  $\mathbf{m}$  corresponds to such and such point in the affine space of  $\mathbf{m}'$ , and that such vector in the first space is parallel or equal to such and such vector in the second.<sup>20</sup>

So far we have defined the notion of an affine connection without defining the affine space. It was a rather abstract way, in which we have used the idea of affine space implicitly, defining the affine connection on a tangent bundle. Now we would like to define a notion of *affine space* explicitly. Roughly speaking, an affine space is some space  $A$  together with some vector space ( $R$ -module), such that we can add a vector  $v$  to the point  $x$  and receive the point  $y = x + v$ , as well as make the difference of two points  $x$  and  $y$ , obtaining the vector  $v = x - y$ .

**Definition 5.1** We say that an (inhabited, i.e.  $\exists a \in A$ ) object (‘set’)  $A$  is equipped with an **affine space structure** or **translation space structure** or **torsor structure** of an additive abelian group  $\langle V, +, 0 \rangle$  (so, in particular, an  $R$ -module) if there are operations

$$V \times A \xrightarrow{+} A, \quad (139)$$

$$A \times A \xrightarrow{-} V, \quad (140)$$

such that

$$\forall \tau_1, \tau_2 \in A \quad \exists! t \in V \quad t + \tau_1 = \tau_2 \iff t = \tau_2 - \tau_1. \quad (141)$$

An **affine space** is the pair  $\langle A, V \rangle$  together with the structure  $\langle 0, +, \dot{+}, \dot{-} \rangle$ .

This definition implies the identities

$$(\tau_2 - \tau_1) + \tau_1 = \tau_2, \quad (142)$$

$$(t + \tau_1) - \tau_1 = t, \quad (143)$$

$$0 + \tau = \tau, \quad (144)$$

$$(t_1 + t_2) + \tau = t_1 + (t_2 + \tau). \quad (145)$$

Consider now the pictures (126), (129) and (136). We would like to have an ability to move from the ‘point’  $\bar{t}(0)$  to  $C(\bar{t})$ , as well as move vector  $\bar{t}$  from  $\bar{t}(0)$  to  $C(\bar{t})$ . In general it is not possible, but in case when  $M = E^D$  we can introduce the affine space structure on the fibre  $M^D \times_m M^D \rightarrow M_m^{D \times D}$  and move between microsquares from  $M^{D \times D}$  along the vectors from  $M_m^D = T_m M$ . Such  $E^D = (M^D)^D \cong M^{D \times D}$  is called the **iterated tangent bundle**.  $E^D$  has two vector bundle structures (one over  $M^D$ , second over  $E$ ), and  $M^{D \times D}$  has also both structures, with the following projections on  $M^D$  (recall that for any exponential objects we have  $(A^B)^C \cong A^{C \times B}$ ):

$$\begin{aligned} (M^D)^D &\xrightarrow{M^{i_2}} M^D, & M^{i_2}(\tau)(d) &= \tau(0, d), \\ (M^D)^D &\xrightarrow{M^{i_1}} M^D, & M^{i_1}(\tau)(d) &= \tau(d, 0), \end{aligned} \quad (146)$$

together with the  $R$ -module structures:

$$\begin{aligned} (\lambda \odot \tau)(d_1, d_2) &= \tau(\lambda d_1, d_2), \\ (\tau \oplus \tau')(d_1, d_2) &= (\tau(-, d_2) + \tau'(-, d_2))(d_1), \\ (\lambda \tau)(d_1, d_2) &= \tau(d_1, \lambda d_2), \\ (\tau + \tau')(d_1, d_2) &= (\tau(d_1, -) + \tau'(d_1, -))(d_2). \end{aligned} \quad (147)$$

<sup>20</sup>[Cartan:1955]

So,  $M^{i_1} : M^{D \times D} \rightarrow M^D$  and  $M^{i_2} : M^{D \times D} \rightarrow M^D$  are Euclidean vector bundles. From this we get the following equations:

$$\begin{aligned} \lambda \cdot (\mu \odot \tau) &= \mu \odot (\lambda \cdot \tau), \\ (\tau_1 \oplus \tau_2) \cdot (\tau'_1 \oplus \tau'_2) &= (\tau_1 \cdot \tau'_1) \oplus (\tau_2 \cdot \tau'_2), \\ \lambda \cdot (\tau_1 \oplus \tau_2) &= (\lambda \cdot \tau_1) \oplus (\lambda \cdot \tau_2), \\ \lambda \cdot (\tau_1 + \tau_2) &= (\lambda \cdot \tau_1) + (\lambda \odot \tau_2). \end{aligned} \tag{148}$$

For  $E = M^D$  we have  $M^D \xrightarrow{\pi} M$  in the place of  $E \xrightarrow{p} M$  and

$$M^{D(2)} \cong M^D \times_M M^D \xrightarrow{\nabla} (M^D)^D \cong M^{D \times D} \tag{149}$$

in the place of  $M^D \times_M E \xrightarrow{\nabla} E^D$ . The map  $K : E^D \rightarrow M^D \times_M E$  becomes  $K : (M^D)^D \cong M^{D \times D} \rightarrow M^D \times_M M^D \cong M^{D(2)}$ . Note that it is a restriction map induced by  $D(2) \mapsto D \times D$ , so there exists an inverse arrow  $K^{-1} : M^{D(2)} \rightarrow M^{D \times D}$ . Hence, for every  $\tau \in M^{D(2)}$  such that  $\tau(0, 0) = m \in M$ , we may consider its inverse image  $K^{-1}(\tau)$ . We will show now, that  $K^{-1}(\tau)$  is equipped with an affine space structure of the  $R$ -module  $T_m M = M_m^D$ , so the fibres of the restriction maps

$$M_m^{D \times D} \longrightarrow M_m^{D(2)} \tag{150}$$

have a natural structure of an affine space over  $M_m^D$ . This will enable us to make a comparison between  $\tau$  and  $\nabla K(\tau)$  (hence, satisfy the Cartan's comparison postulate), and to introduce the familiar equations on covariant derivative, torsion and Lie brackets.

**Definition 5.2** A *strong difference* is a pair of maps

$$\dot{-} : M^{D \times D} \times_{M^{D(2)}} M^{D \times D} \rightarrow M^D, \tag{151}$$

$$\dot{+} : M^D \times_M M^{D \times D} \rightarrow M^{D \times D}, \tag{152}$$

such that for  $t \in M^D$ ,  $\tau_1, \tau_2 \in M^{D \times D}$ ,  $\tau_1|_{D(2)} = \tau_2|_{D(2)} = \tau$ :

$$(\tau_2 \dot{-} \tau_1)(d) := f(0, 0, d), \tag{153}$$

$$(t \dot{+} \tau)(d_1, d_2) := g(d_1, d_2, d_1 \cdot d_2), \tag{154}$$

where  $(D \times D) \vee D := \{(d_1, d_2, d_3) | d_1^2 = d_2^2 = d^2 = d_1 d = d_2 d = 0\}$  and  $f, g : (D \times D) \vee D \rightarrow M$  are such functions that

$$f(d_1, d_2, 0) = \tau_1(d_1, d_2), \tag{155}$$

$$f(d_1, d_2, d_1 \cdot d_2) = \tau_2(d_1, d_2), \tag{156}$$

$$g(d_1, d_2, 0) = \tau(d_1, d_2), \tag{157}$$

$$g(0, 0, d) = t(d). \tag{158}$$

**Proposition 5.3**  $f$  and  $g$  are unique.

**Proof.** Consider the diagrams

$$\begin{array}{ccc} D(2) & \xrightarrow{i} & D \times D \\ i \downarrow & & \downarrow \psi \\ D \times D & \xrightarrow{\phi} & (D \times D) \vee D \end{array} \tag{159}$$

and

$$\begin{array}{ccc} 1 & \longrightarrow & D \\ \downarrow & & \downarrow \varepsilon \\ D \times D & \xrightarrow{\phi} & (D \times D) \vee D, \end{array} \quad (160)$$

where

$$\begin{aligned} \phi(d_1, d_2) &= (d_1, d_2, 0), \\ \psi(d_1, d_2) &= (d_1, d_2, d_1 \cdot d_2), \\ \varepsilon(d) &= (0, 0, d), \end{aligned} \quad (161)$$

while  $i$  are the inclusion arrows. Let us take two maps  $\tau'_1, \tau'_2 \in R^{D \times D}$ , given by

$$\begin{aligned} \tau'_1(d_1, d_2) &= a + b_1 d_1 + b_2 d_2 + c_1 d_1 d_2, \\ \tau'_2(d_1, d_2) &= a + b_1 d_1 + b_2 d_2 + c_2 d_1 d_2. \end{aligned} \quad (162)$$

By definition  $f(d_1, d_2, 0) := a + b_1 d_1 + b_2 d_2 + c_1 d_1 d_2 + (c_2 - c_1)d$  we obtain  $f(d_1, d_2, 0) = \tau'_1(d_1, d_2)$  and  $f(d_1, d_2, d_1 \cdot d_2) = \tau'_2(d_1, d_2)$ , thus  $R$  perceives (159) as pullback, hence, by microlinearity,  $M$  perceives it too. Similarly for (160).  $\square$

**Proposition 5.4** *The strong difference  $\dot{-}$  and  $\dot{+}$  equips  $K^{-1}(\tau)$  with an affine space structure of the  $R$ -module  $T_x M = M_x^D$ .*

**Proof.** We have to show that equations (142-145) hold for  $\dot{-}$  and  $\dot{+}$  defined by (153-158).

1. The definition of  $\dot{+}$  gives us  $((\tau_2 \dot{-} \tau_1) \dot{+})(d_1, d_2) = \tilde{f}(d_1, d_2, d_1 \cdot d_2)$  for  $\tilde{f}$  such that  $\tilde{f}(0, 0, d) = (\tau_2 \dot{-} \tau_1)(d)$  and  $\tilde{f}(d_1, d_2, 0) = \tau_1(d_1, d_2)$ . The definition of  $\dot{-}$  states  $(\tau_2 \dot{-} \tau_1)(d) = \tilde{f}(0, 0, d)$  for  $\tilde{f}(d_1, d_2, d_1 \cdot d_2) = \tau_2(d_1, d_2)$ . Thus, we have  $\tilde{f} = \tilde{f}$  and  $\tilde{f}(d_1, d_2, d_1 \cdot d_2) = \tau_2(d_1, d_2)$ , hence  $(\tau_2 \dot{-} \tau_1) \dot{+} \tau_1 = \tau_2$ . The same procedure gives  $(t \dot{+} \tau) \dot{-} \tau = t$  and  $0 \dot{+} \tau = \tau$ .
2. To show that  $(t_1 + t_2) \dot{+} \tau_2 = t_1 \dot{+} (t_2 \dot{+} \tau)$ , consider the diagram

$$\begin{array}{ccc} D \times D & \xrightarrow{0} & D \\ \downarrow 0 & & \downarrow j_1 \\ (D \times D) \vee D & \xrightarrow{j_2} & (D \times D) \vee D(2), \end{array} \quad (163)$$

where  $(D \times D) \vee D(2) := \{(d_1, d_2, e_1, e_2) \in D^4 \mid d_i^2 = e_i^2 = d_i e_i = e_1 e_2 = 0, i \in \{1, 2\}\}$ ,  $j_1(d) := (0, 0, d)$  and  $j_2(d_1, d_2, e) := (d_1, d_2, 0, e)$ . For the unique  $g$  such as specified in (157) and (158), we have  $((t_1 + t_2) \dot{+} \tau)(d_1, d_2) = g(d_1, d_2, d_1 \cdot d_2)$ . For the unique  $f : (D \times D) \vee D \rightarrow M$  given by  $f(d_1, d_2, 0) = \tau(d_1, d_2)$  and  $f(0, 0, d) = t_2(d)$  we can define  $h : (D \times D) \vee D(2) \rightarrow M$  given by  $h(d_1, d_2, 0, e) := f(d_1, d_2, e)$  and  $h(0, 0, d, 0) = t_1(d)$ , which is unique, because for  $h : (D \times D) \vee D(2) \rightarrow R$  the diagram (163) is sent to the pushout diagram, what can be easily checked in a standard manner. For such  $h$  we have  $h(0, 0, 0, e) = t_2(e)$ , hence  $h(0, 0, e, e) = (t_1 + t_2)(e)$ . Finally, we have  $h(d_1, d_2, e, e) = g(d_1, d_2, e)$ . Now, using that  $h(0, 0, e, 0) = t_1(0)$ , we conclude that  $(t_2 \dot{+} \tau)(d_1, d_2) = h(d_1, d_2, 0, d_1 d_2)$  implies  $(t_1 \dot{+} (t_2 \dot{+} \tau)) = h(d_1, d_2, d_1 d_2, d_1 d_2)$ , and so  $t_1 \dot{+} (t_2 \dot{+} \tau) = (t_1 + t_2) \dot{+} \tau$ .

$\square$

Hence, for  $m = \tau(0, 0)$  we have:

$$K^{-1}(\tau) \times K^{-1}(\tau) \xrightarrow{\dot{-}} T_m M, \quad (164)$$



$$T_m M \times K^{-1}(\tau) \xrightarrow{\dot{+}} K^{-1}(\tau). \quad (165)$$

**Definition 5.5** The *twist map*  $\Sigma : M^{D \times D} \rightarrow M^{D \times D}$  is a map such that

$$\Sigma(\tau)(d_1, d_2) := \tau(d_2, d_1). \quad (166)$$

Clearly, it is a map of vector bundles:

$$\begin{array}{ccc} M^{D \times D} & \xrightarrow{\Sigma} & M^{D \times D} \\ & \searrow^{M^{i_2}} & \swarrow_{M^{i_1}} \\ & M^D & \end{array} \quad (167)$$

**Corollary 5.6** Considering the proof given above, for  $\tau, \tau_1, \tau_2 \in M_m^{D \times D}$ ,  $t \in M_m^D$ ,  $K^{-1}(\tau_1) = K^{-1}(\tau_2)$ ,  $\lambda \in R$ , we have

$$\begin{aligned} \tau_2 \dot{-} \tau_1 &= \Sigma(\tau_2) \dot{-} \Sigma(\tau_1), \\ \Sigma(t \dot{+} \tau) &= t \dot{+} \Sigma(\tau), \end{aligned} \quad (168)$$

and

$$\begin{aligned} \lambda \cdot (\tau_2 \dot{-} \tau_1) &= (\lambda \cdot \tau_2) \dot{-} (\lambda \cdot \tau_1) = (\lambda \odot \tau_2) \dot{-} (\lambda \odot \tau_1), \\ \lambda \cdot (t \dot{+} \tau) &= \lambda \cdot t \dot{+} \lambda \cdot \tau, \\ \lambda \odot (t \dot{+} \tau) &= \lambda \cdot t \dot{+} \lambda \odot \tau. \end{aligned} \quad (169)$$

**Proposition 5.7** For  $X, Y : D \rightarrow M^M$ ,

$$[X, Y] = Y \cdot X \dot{-} \Sigma(X \cdot Y). \quad (170)$$

**Proof.** We have  $(X \cdot Y)(d_1, d_2) = Y_{d_2} \circ X_{d_1}$ , so  $\Sigma(X \cdot Y)(d_1, d_2) = X_{d_1} \circ Y_{d_2}$  on  $D(2)$  (cf. (3.10)). Let us define  $h : (D \times D) \vee D \rightarrow M^M$  such that  $h(d_1, d_2, e) = X_{d_1} \circ [X, Y]_e \circ Y_{d_2}$ . Hence,  $h(d_1, d_2, 0) = X_{d_1} \circ Y_{d_2} = \Sigma(X \cdot Y)(d_1, d_2)$ , and  $h(d_1, d_2, d_1 \cdot d_2) = X_{d_1} \circ [X, Y]_{d_1, d_2} \circ Y_{d_2} = X_{d_1} \circ (X_{-d_1} \circ Y_{d_2} \circ X_{d_1} \circ Y_{-d_2}) \circ Y_{d_2} = Y_{d_2} \circ X_{d_1} = (Y \cdot X)(d_1, d_2)$ . Thus,  $[X, Y]_e = h(0, 0, e) = (Y \cdot X \dot{-} \Sigma(X \cdot Y))(e)$ .  $\square$

**Proposition 5.8** Let  $C : M^{D \times D} \rightarrow M^D$  be a connection map of an affine connection  $\nabla$ , and  $\tau, \tau' \in M^{D \times D}$  such that  $K(\tau) = K(\tau')$ . Then

$$C(\tau) = \tau \dot{-} \nabla \circ K(\tau) = \tau \dot{-} \nabla(t_1, t_2), \quad (171)$$

$$C(\tau) - C(\tau') = \tau \dot{-} \tau'. \quad (172)$$

**Proof.** By the definition of strong difference, we have  $(\tau \dot{-} \nabla(t_1, t_2))(e) = f(0, 0, e)$ , where  $f : (D \times D) \vee D \rightarrow M$  is a unique function such that  $f(d_1, d_2, 0) = \nabla(t_1, t_2)(d_1, d_2)$  and  $f(d_1, d_2, d_1 d_2) = \tau(d_1, d_2)$ . From  $f(0, d_2, 0) = t_2(d_2)$  we get  $f(0, d_2, d_1 d_2) = (t_2 + d_1(\tau \dot{-} \nabla(t_1, t_2)))(d_2)$ . Now let us define  $g : D(2) \times D \rightarrow M$  such that  $g(d_1, d_2, d) = f(d_1 - d_2, d, d_1 d)$ , which is good definition, because  $(d_1, d_2) \in D(2), d \in D \Rightarrow (d_1 - d_2, d, d_1 d) \in (D \times D) \vee D$ . For such  $g$  we have  $g(d_1, 0, d) = f(d_1, d, d_1 d) = \tau(d_1, d)$  and  $g(0, d_2, d) = f(-d_2, d, 0) = \nabla(t_1, t_2)(-d_2, d)$ , thus  $g(d_1, d_1, d_2) = (\tau \ominus \nabla(t_1, t_2))(d_1, d_2) = f(0, d_2, d_1 d_2) = t_2 + d_1(\tau \dot{-} \nabla(t_1, t_2))(d_2)$ . On the other hand  $C : M^{D \times D} \rightarrow M^D$  is defined as  $(\tau \ominus \nabla \circ K(\tau))(d_1, d_2) = (t_2 + d_1 \cdot C(\tau))(d_2)$  (see (119) and (130)), thus  $C(\tau) = \tau \dot{-} \nabla(t_1, t_2)$ . The second equation follows immediately.  $\square$

**Corollary 5.9** *Let  $X, Y : D \rightarrow M^M$ . As  $\nabla_X Y = C(Y \cdot X)$ , we have  $\nabla_X Y = Y \cdot X \dot{-} \nabla(K(Y, X))$ , hence*

$$\nabla_X Y = Y \cdot X \dot{-} \nabla(X, Y). \quad (173)$$

**Definition 5.10** *The **torsion** of an affine connection  $\nabla$  with connection map  $C$  is a map  $T : M^{D \times D} \rightarrow M^D$  such that for  $\tau \in M^{D \times D}$*

$$T(\tau) := C(\tau) - C(\Sigma(\tau)). \quad (174)$$

*Connection is called **torsion free** if  $T(\tau) = 0$  for all  $\tau$ .*

**Proposition 5.11** 1. *Connection is torsion free if it is symmetric.*

2.  $T(X, Y) = C(Y \cdot X) - C(\Sigma(Y \cdot X))$ .
3.  $T(X, Y) = \nabla_X Y - \nabla_Y X - [X, Y]$ .

**Proof.**

1. Let  $K(\tau) = (t_1, t_2)$ . By (174) we have  $T(\tau) = C(\tau) - C(\Sigma(\tau)) = (\tau \dot{-} \nabla \circ K(\tau)) - (\Sigma(\tau) \dot{-} \Sigma(\nabla \circ K(\tau))) = (\tau \dot{-} \nabla(t_1, t_2)) - (\Sigma(\tau) \dot{-} \Sigma(\nabla(t_1, t_2))) = (\tau \dot{-} \nabla(t_1, t_2)) - (\Sigma(\tau) \dot{-} \nabla(t_2, t_1))$ . Thus, symmetrical  $\nabla$  gives  $T(\tau) = 0$ .
2. Obvious from (174).
3.  $T(X, Y) = C(Y \cdot X) - C(\Sigma(Y \cdot X)) = (Y \cdot X \dot{-} \nabla(Y, X)) - (\Sigma(Y \cdot X) \dot{-} \Sigma(\nabla(Y, X))) = (Y \cdot X \dot{-} \nabla(Y, X)) - ((X \cdot Y - [Y, X]) \dot{-} \nabla(X, Y)) = \nabla_X Y - \nabla_Y X - [X, Y]$ .

□

The notion of strong difference was considered in the context of classical differential geometry by Kolař [Kolar:1977], [Kolar:1982] and White [White:1982]. The notion of iterated tangent bundle in the classical context can be found in [Godbillon:1969]. In the synthetical context it can be generalized to higher dimensional cases. In the series of papers of Hirokazu Nishimura ([Nishimura:1997a], [Nishimura:1997b] and further) the theory of three-dimensional strong difference of microsquares as well as elements of higher-dimensional theory was developed. The higher-dimensional proofs are however engaged in quite long calculations (much longer than these of propositions 5.4 and 5.8), so we will present here only the main idea and result of this area of development. First, let us note that we can generalize a notion of a microsquare  $\tau : D \times D \rightarrow M$  to the notion of a ***n*-microcube**  $\tau : D \times \dots \times D \rightarrow M$ , i.e.  $\tau \in M^{D^n}$ , and denote the object of *n*-microcubes at  $m$  as  $T^n(M, m) := M_m^{D^n}$ . Recall that in the proposition 5.7 we have expressed the Lie bracket  $[X, Y]$  in terms of strong difference:

$$[X, Y] = Y \cdot X - \Sigma(X \cdot Y). \quad (175)$$

$X$  and  $Y$  are the maps  $D \rightarrow M^M$ , hence they belong to  $T^1(M^M, \text{id}_M)$ .  $[X, Y] \in T^1(M^M, \text{id}_M)$  too (cf. corollary 3.10). On the other hand,  $Y \cdot X$  and  $\Sigma(X \cdot Y)$  are the elements of  $T^2(M^M, \text{id}_M)$ , hence we can say that the Lie bracket in  $T^1(M^M, \text{id}_M)$  is expressed by the strong difference – in  $T^2(M^M, \text{id}_M)$ . This leads us to concern an object  $[X, [Y, Z]] \in T^2(M^M, \text{id}_M)$ , which should be obtained by the strong difference in  $T^3(M^M, \text{id}_M)$ . However, in this three-dimensional case there are *three different* strong differences  $-_1, -_2, -_3$ , corresponding to three different ways of establishing the link between microcubes (3-microcubes) on  $M$  and microsquares (2-microcubes) on  $M^D$ . If we would like to establish the Jacobi identity in terms of strong difference, we will

be involved in considering  $\dot{-}_1$ ,  $\dot{-}_2$ ,  $\dot{-}_3$  and also  $\dot{-}$ . Thus, it suffices here to say that in this framework the Jacobi identity

$$[X, [Y, Z]] + [Y, [Z, X]] + [Z, [X, Y]] = 0 \quad (176)$$

can be successfully established. We refer reader to the papers of Nishimura for details.

## 6 Differential forms

**Definition 6.1** An *n-microcube* is a map  $\gamma$  from  $D^n$  to  $M$ . A *marked n-microcube* is an *n-microcube* together with an element of  $D^n$  (called the **marking**):

$$(\gamma, h_1, \dots, h_n) \in M^{D^n} \times D^n. \quad (177)$$

An object of *infinitesimal n-chains* is the free  $R$ -module generated by the marked *n-microcube* on  $M$ :

$$\forall a_i \in R \quad \sum_{i=1}^j a_i \cdot (\gamma_i, h_1^i, \dots, h_n^i) \in C_n(M). \quad (178)$$

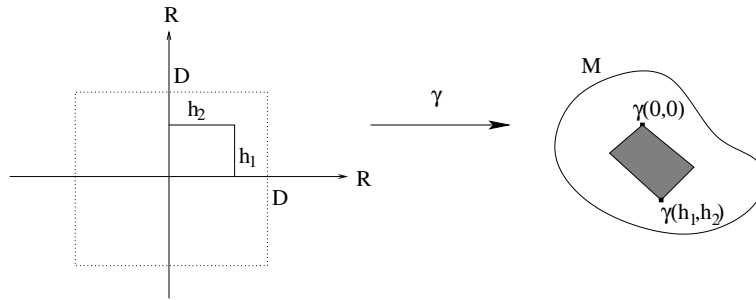

Thus, the images of marked microcubes on  $M$  are the *n-surfaces*. We will define the differential *n-forms* to measure such *n-surfaces*, i.e. to assign numbers to *n-forms* (in one-dimensional case it will be the length, in two-dimensional – area, in 3-dimensional – volume, and so on), however we will do it in a bit more general way, considering them as morphisms not into the ring  $R$ , but into some Euclidean  $R$ -module. Recall that in the previous chapter we have discussed the fact that maps

$$M^{i_1} : M^{D \times D} \rightarrow M^D \quad (179)$$

$$M^{i_2} : M^{D \times D} \rightarrow M^D \quad (180)$$

are Euclidean fibre bundles. In the same way we may say that

$$M^{i_k} : M^{D^n} \rightarrow M^{D^{n-1}} \quad (181)$$

is an Euclidean fibre bundle. Thus, if we have some  $\gamma \in M^{i_k}$ , then it is *n-homogeneous*

$$\gamma(d_1, \dots, \lambda \cdot d_k, \dots, d_n) =: \lambda \cdot \gamma(d_1, \dots, d_k, \dots, d_n), \quad (182)$$

and the *n-twist* map  $\Sigma : M^{D^n} \rightarrow M^{D^n}$  induces the permutation  $\sigma$  of indice numbers

$$\Sigma(\gamma)(d_1, \dots, d_n) := \gamma(d_{\sigma(1)}, \dots, d_{\sigma(n)}). \quad (183)$$

**Definition 6.2** The *k-linear form*  $\alpha$  on  $M$  is a  $k$ -homogeneous map  $\alpha : M^{D^k} \rightarrow R$ . We denote the object of  $k$ -linear forms on  $M$  as  $L^k M$  or  $\otimes^k M$ . The **tensor product**  $\alpha \otimes \beta \in L^{p+q} M$  of two  $k$ -linear forms  $\alpha \in L^p M$  and  $\beta \in L^q M$  is defined as bilinear map

$$(\alpha \otimes \beta) : M^{D^p} \times M^{D^q} \cong M^{D^{p+q}} \ni \gamma \mapsto \alpha(\gamma(-, \underbrace{0, \dots, 0}_q)) \cdot \beta(\gamma(\underbrace{0, \dots, 0}_p, -)) \in L^{p+q} M. \quad (184)$$

Obviously, this definition implies that

$$(\alpha \otimes \beta) \otimes \delta = \alpha \otimes (\beta \otimes \delta). \quad (185)$$

$L^p M$  is an microlinear Euclidean  $R$ -module, because  $L^p M \mapsto R^{M^{D^p}}$ . In particular, for  $k = 1$ , we have  $\alpha : M^D \rightarrow R$ , so it is a linear form which assigns the value in  $R$  to a vector from tangent bundle  $M^D$ . In this case we may define the object of linear forms on tangent bundle  $T^* M := L^1 M$  and its fibre over  $x$ ,  $T_x^* M := L^1 M_x$ .

**Definition 6.3** The *classical k-linear form*  $\alpha$  on  $M$  is a  $k$ -homogeneous map

$$\alpha : M^{D(k)} \cong M^D \times_M \dots \times_M M^D \rightarrow R. \quad (186)$$

We denote the object of  $k$ -linear classical forms as  $\tilde{L}^k M$  or  $\widetilde{\otimes}^k M$ . The **classical tensor product**  $\alpha \widetilde{\otimes} \beta \in \tilde{L}^{p+q} M$  of two  $k$ -linear forms  $\alpha \in \tilde{L}^p M$  and  $\beta \in \tilde{L}^q M$  is defined as bilinear map

$$(\alpha \widetilde{\otimes} \beta) : M^{D(p)} \times_M M^{D(q)} \cong M^{D(p+q)} \ni \gamma \mapsto \alpha(\gamma(-, \underbrace{0, \dots, 0}_q)) \cdot \beta(\gamma(\underbrace{0, \dots, 0}_p, -)) \in \tilde{L}^{p+q} M. \quad (187)$$

This definition also implies that

$$(\alpha \widetilde{\otimes} \beta) \widetilde{\otimes} \delta = \alpha \widetilde{\otimes} (\beta \widetilde{\otimes} \delta). \quad (188)$$

By the obvious reason,  $T^* M = L^1 M = \tilde{L}^1 M$  and  $T_x^* M = L^1 M_x = \tilde{L}^1 M_x$ . By introducing the notation  $TM \widetilde{\otimes} TM$  for  $M^D \times_M M^D$ , we may define the (**classical**) **tensor bundles**:

$$\begin{aligned} r\text{-contravariant tensor bundle} & \quad T_r := \widetilde{\otimes}_r M := \widetilde{\otimes}_{i=1}^r TM \\ s\text{-covariant tensor bundle} & \quad T^s := \widetilde{\otimes}^s M := \widetilde{\otimes}_{j=1}^s T^* M \\ r\text{-contravariant-}s\text{-covariant tensor bundle} & \quad T_r^s := \widetilde{\otimes}_r^s M := \left( \widetilde{\otimes}_{i=1}^r TM \right) \times_M \left( \widetilde{\otimes}_{j=1}^s T^* M \right) \end{aligned} \quad (189)$$

as well as their fibres  $(T_r)_x := \widetilde{\otimes}_{i=1}^r T_x M$ ,  $(T^s)_x := \widetilde{\otimes}_{j=1}^s T_x^* M$  and  $(T_r^s)_x := \left( \widetilde{\otimes}_{i=1}^r T_x M \right) \times_M \left( \widetilde{\otimes}_{j=1}^s T_x^* M \right)$ . Note that the connection  $\nabla : M^D \times_M E \rightarrow E^D$  was defined for any microlinear space  $E$  which fibres are Euclidean  $R$ -modules. This enables us to easily extend the action of a connection map from vector to (classical) tensor fields:

$$\nabla : M^D \times_M \left( \widetilde{\otimes}_r^s M \right) \rightarrow \left( \widetilde{\otimes}_r^s M \right)^D, \quad (190)$$

i.e.

$$\nabla : M^D \times_M T \rightarrow T^D. \quad (191)$$

We can define naturally the covariant derivative on the (classical) tensor bundle  $T$  by

$$C(T^D \circ X) = C(T \cdot X) = \nabla_X T =: (\nabla T)(X), \quad (192)$$

with properties given by the proposition 4.12. The action of the covariant derivative  $\nabla_X$  is a map  $\nabla_X : T \rightarrow \nabla_X T$ . Note that in classical differential geometry connection on tensor fields is often introduced by taking first the partial derivative and adding corrections to it, to get the covariant result (see for example [Schutz:1982] or [Wald:1984]). Here we have got the connection on tensor bundle easily without any coordinate-involving calculations.

**Definition 6.4** A **differential  $n$ -form** on  $M$  with the value in some Euclidean  $R$ -module  $V$  is the map  $\omega : M^{D^n} \rightarrow V$  such that for every  $i \in \{1, \dots, n\}$ ,  $\gamma \in M^{D^n}$ ,  $\lambda \in R$

1. ( *$n$ -homogeneity*)  $\omega(\lambda \cdot_i \gamma) = \lambda \omega(\gamma)$ ,
2. (*alternation*)  $\omega(\Sigma(\gamma)) = \text{sgn } \sigma \cdot \omega(\gamma)$ .

The object of differential forms  $\omega : M^{D^n} \rightarrow E$  is denoted as  $\Lambda^n(M, V)$ . For  $V = R$  we use the notation  $\Lambda^n M$  instead of  $\Lambda^n(M, R)$ . A **classical differential  $n$ -form** is defined as a map  $\tilde{\omega} : M^{D(n)} \rightarrow V$  with the same properties as (non-classical) differential  $n$ -form. The object of classical differential forms is denoted as  $\tilde{\Lambda}^n(M, V)$ . For  $V = R$  we denote it as  $\tilde{\Lambda}^n R$ . We also use the notation

$$\Lambda M := \bigotimes_{n=1}^{\infty} \tilde{\Lambda}^n M. \quad (193)$$

Note that we can define a differential  $n$ -form using the marked  $n$ -microcubes, writing publicly the  $n$ -homogeneity and alternation conditions as

$$\omega(\lambda \cdot_i \gamma, h_1, \dots, h_n) = \lambda \cdot \omega(\gamma, h_1, \dots, h_n), \quad (194)$$

$$\omega(\Sigma(\gamma), h_1, \dots, h_n) = \text{sgn } \sigma \cdot \omega(\gamma, h_{\sigma(1)}, \dots, h_{\sigma(n)}), \quad (195)$$

and adding the degeneracy condition

$$\omega(\gamma, h_1, \dots, 0, \dots, h_n) = 0. \quad (196)$$

This condition, enables us by the Kock-Lawvere axiom to write the marked  $n$ -form as  $\omega(\gamma, h_1, \dots, h_n) = h_1 \cdot \dots \cdot h_n \cdot \omega'(\gamma)$ , where  $\omega'(\gamma)$  is the corresponding unique (not-marked)  $n$ -form. Thus, marked and not-marked  $n$ -forms may be identified with each other. The action of marked  $n$ -form is denoted as

$$\omega : M^{D^n} \times D^n \ni (\gamma, h_1, \dots, h_n) \mapsto \omega(\gamma, h_1, \dots, h_n) = h_1 \cdot \dots \cdot h_n \cdot \omega(\gamma) =: \int_{(\gamma, h_1, \dots, h_n)} \omega \in V, \quad (197)$$

which gives a map

$$\int_{(-)} \omega : C_n(M) \rightarrow V. \quad (198)$$

**Proposition 6.5**  $\Lambda^n(M, V)$  is a microlinear Euclidean  $R$ -module and a module over the algebra of functions from  $R^M$ .

**Proof.** First part is obvious, because  $\Lambda^n(M, V) \hookrightarrow V^{M^{D^n}}$ , and  $V^{M^{D^n}}$  is an exponential of microlinear spaces, thus a microlinear space. Taking some  $\omega \in \Lambda^n(M, V)$  and  $f \in R^M$ , we may define  $f \cdot \omega : M^{D^n} \rightarrow V$  as

$$(f \cdot \omega)(\gamma) = f(\gamma(0, \dots, 0)) \cdot \omega(\gamma). \quad (199)$$

□

As we see,  $\Lambda^p M \hookrightarrow L^p M$ . The tensor product of two *differential* forms is a linear form, but is not alternated, thus it is not a differential form. However, we may solve this problem, considering the antisymmetrization map  $A : L^p M \rightarrow \Lambda^p M$ .

**Definition 6.6** The *antisymmetrization map*  $A(\alpha) : M^{D^k} \rightarrow R$  of the form  $\alpha$  is defined as

$$A(\alpha)(\gamma) = \sum_{\sigma} \text{sgn } \sigma \cdot \alpha(\Sigma(\gamma)). \quad (200)$$

Thus,  $A$  is a linear map  $A : L^p M \rightarrow \Lambda^p M$ , and for any  $\alpha \in L^p M$  and  $\beta \in L^q M$  we have

$$A(\alpha \otimes \beta) = (-1)^{pq} A(\beta \otimes \alpha). \quad (201)$$

**Definition 6.7** The *exterior product* of two differential forms  $\omega_1 \in \Lambda^p M$  and  $\omega_2 \in \Lambda^q M$  is the differential form  $\omega_1 \wedge \omega_2 \in \Lambda^{p+q} M$  such that

$$\omega_1 \wedge \omega_2 = (p! \cdot q!)^{-1} A(\omega_1 \otimes \omega_2). \quad (202)$$

As a consequence of this definition we immediately get

$$\omega_1 \wedge \omega_2 = (-1)^{pq} \omega_2 \wedge \omega_1. \quad (203)$$

Expressing the action of an exterior product of differential forms on some microcube, we get

$$\omega_1 \wedge \omega_2(\gamma(d_1, \dots, d_n)) = \frac{1}{p!q!} \sum_{\sigma} \text{sgn } \sigma \cdot \omega_1(\gamma(d_{\sigma(1)}, \dots, d_{\sigma(p)})) \otimes \omega_2(\gamma(d_{\sigma(p+1)}, \dots, d_{\sigma(p+q)})). \quad (204)$$

Consider now the map  $f : M \rightarrow N$  of microlinear spaces. We can define the contravariant functor  $\Lambda^n(-, V)$  such that

$$\begin{array}{ccc} M & \xrightarrow{f} & N \\ & \downarrow \Lambda^n(-, E) & \\ \Lambda^n(M, E) & \xleftarrow{f^*} & \Lambda^n(N, E), \end{array} \quad (205)$$

where  $f^*$  is given by  $(f^*\omega)(\gamma) = \omega(f \circ \gamma)$  for  $\gamma \in M^D$  and  $\omega \in \Lambda^n(N, V)$ . We should check that this definition is correct, i.e. that  $f^*\omega \in \Lambda^n(M, V)$ , but this follows immediately from the definition above. Moreover, it naturally extends on the  $k$ -linear forms and their tensor products. For  $\alpha \in L^p M$  we have  $f^* : L^p M \rightarrow L^p N$  given by  $(f^*\alpha)(\gamma) = \alpha(f \circ \gamma)$ . Obviously, this implies that

$$f^*(A(\alpha)) = A(f^*\alpha), \quad (206)$$

$$f^*(\alpha \otimes \beta) = f^*\alpha \otimes f^*\beta, \quad (207)$$

$$f^*(\omega_1 \wedge \omega_2) = f^*\omega_1 \wedge f^*\omega_2. \quad (208)$$

**Definition 6.8** *The boundary operator*

$$\partial : C_{n+1}(M) \rightarrow C_n(M) \quad (209)$$

is given by

$$\partial(\gamma, h_1, \dots, h_n) := \sum_{i=1}^{n+1} (-1)^i F_0^i(\gamma, h_1, \dots, h_n) - \sum_{i=1}^{n+1} (-1)^i F_1^i(\gamma, h_1, \dots, h_n), \quad (210)$$

where  $F_0^i$  and  $F_1^i$  are marked  $n$ -microcubes defined as

$$F_0^i(\gamma, h_1, \dots, h_n) = (((d_1, \dots, d_n) \mapsto \gamma(d_1, \dots, d_{i-1}, 0, d_i, \dots, d_n)), h_1, \dots, \hat{h}_i, \dots, h_{n+1}), \quad (211)$$

$$F_1^i(\gamma, h_1, \dots, h_n) = (((d_1, \dots, d_n) \mapsto \gamma(d_1, \dots, d_{i-1}, h_i, d_i, \dots, d_n)), h_1, \dots, \hat{h}_i, \dots, h_{n+1}), \quad (212)$$

where  $\hat{h}_i$  means dropping the  $i$ -th element  $h_i$ .

**Example** Let  $\gamma \in M^{D^2}$  and  $(d_1, d_2) \in D^2$ . Then we have  $\partial(\gamma, d_1, d_2) = -F_0^1(\gamma, d_1, d_2) + F_0^2(\gamma, d_1, d_2) + F_1^1(\gamma, d_1, d_2) - F_1^2(\gamma, d_1, d_2) = -(\gamma(0, \cdot), d_2) + (\gamma(\cdot, 0), d_1) + (\gamma(d_1, \cdot), d_2) - (\gamma(\cdot, d_2), d_1)$ .

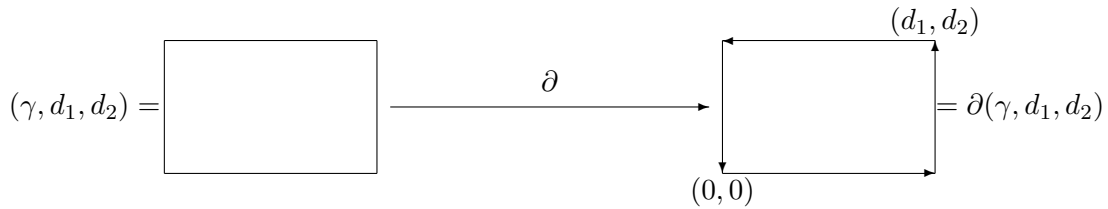

**Proposition 6.9**

$$\partial\partial = 0. \quad (213)$$

**Proof.** Let us denote  $(h_1, \dots, h_n)$  as  $\mathbf{h}$ . We have  $\partial(\partial(\gamma, \mathbf{h})) = \partial(\sum_{i=1}^{n+1} (-1)^i F_0^i(\gamma, \mathbf{h}) - \sum_{i=1}^{n+1} (-1)^i F_1^i(\gamma, \mathbf{h})) = \sum_{i=1}^{n+1} (-1)^i \partial(F_0^i(\gamma, \mathbf{h})) - \sum_{i=1}^{n+1} (-1)^i \partial(F_1^i(\gamma, \mathbf{h})) = \sum_{i=1}^{n+1} (-1)^i [\sum_{j=1}^n (-1)^j F_0^j(F_0^i(\gamma, \mathbf{h})) - \sum_{j=1}^n (-1)^j F_1^j(F_0^i(\gamma, \mathbf{h}))] - \sum_{i=1}^{n+1} (-1)^i [\sum_{j=1}^n (-1)^j F_0^j(F_1^i(\gamma, \mathbf{h})) - \sum_{j=1}^n (-1)^j F_1^j(F_1^i(\gamma, \mathbf{h}))]$ . We have  $F_a^j(F_b^i(\gamma, \mathbf{h})) = F_b^{i-1}(F_a^j(\gamma, \mathbf{h}))$  for  $a, b \in \{0, 1\}$ . If we apply this to the equation above we see that all the terms cancel.  $\square$

**Definition 6.10** Let  $\partial : C_{n+1}(M) \rightarrow C_n(M)$  and  $\omega : M^{D^n} \times D^n \rightarrow V$ . The *exterior derivative* or *exterior differential* is the map

$$d : \Lambda^n(M) \rightarrow \Lambda^{n+1}(M). \quad (214)$$

given by

$$\int_{(\gamma, h_1, \dots, h_{n+1})} d\omega := \int_{\partial(\gamma, h_1, \dots, h_{n+1})} \omega. \quad (215)$$

Note that this definition implies that

$$h_1 \cdot \dots \cdot h_n \cdot d\omega(\gamma) = \int_{(\gamma, h_1, \dots, h_{n+1})} d\omega = \int_{\partial(\gamma, h_1, \dots, h_{n+1})} \omega = \omega(\partial(\gamma, h_1, \dots, h_n)), \quad (216)$$

hence

$$h_1 \cdot \dots \cdot h_n \cdot d\omega(\gamma) = \sum_{i=1}^n (-1)^i h_1 \cdot \dots \cdot h_n \cdot (\omega(\gamma_0^i) - \omega(\gamma_1^i)), \quad (217)$$

where

$$\gamma_0^i(d_1, \dots, d_n) = \gamma(d_1, \dots, d_{i-1}, 0, d_i, \dots, d_n), \quad (218)$$

$$\gamma_1^i(d_1, \dots, d_n) = \gamma(d_1, \dots, d_{i-1}, h_i, d_i, \dots, d_n). \quad (219)$$

**Proposition 6.11**

$$dd = d^2 = 0. \quad (220)$$

**Proof.** Follows immediately from the definition of  $d$  and  $\partial^2 = 0$ .  $\square$

**Proposition 6.12** For  $\omega_1 \in \Lambda^p M$  and  $\omega_2 \in \Lambda^q M$

$$d(\omega_1 \wedge \omega_2) = d\omega_1 \wedge \omega_2 + (-1)^p \omega_1 \wedge d\omega_2. \quad (221)$$

**Definition 6.13** The *interior product*  $X \lrcorner \omega$  of a differential  $k$ -form  $\omega$  with a vector field  $X$  is the map

$$X \lrcorner \omega : M^{D^{k-1}} \rightarrow R \quad (222)$$

given by

$$(X \lrcorner \omega)(\gamma) := \omega(X_{d_1}(\gamma(d_2, \dots, d_k))). \quad (223)$$

**Definition 6.14** The *Lie derivative*  $\mathcal{L}_X \omega \in \Lambda^p M$  of a  $k$ -linear differential form  $\omega \in \Lambda^p M$  along the direction of the vector field  $X \in \mathcal{X}(M)$  is given by

$$d \cdot \mathcal{L}_X \omega(\gamma) := \omega(X_d \circ \gamma) - \omega(\gamma). \quad (224)$$

**Proposition 6.15** The map

$$\mathcal{X}(M) \times \Lambda^k M \ni (X, \omega) \longmapsto X \lrcorner \omega \in \Lambda^{k-1} M \quad (225)$$

is bilinear and for  $\omega_1 \in \Lambda^p M$ ,  $\omega_2 \in \Lambda^q M$  we have

1.  $X \lrcorner (\omega_1 \wedge \omega_2) = (X \lrcorner \omega_2) \wedge \omega_1 + (-1)^p \omega_2 \wedge (X \lrcorner \omega_1)$ ,
2.  $\mathcal{L}_X \omega = X \lrcorner d\omega + dX \lrcorner \omega$ .
3.  $\mathcal{L}_X (\omega_1 \wedge \omega_2) = \mathcal{L}_X \omega_1 \wedge \omega_2 + \omega_1 \wedge \mathcal{L}_X \omega_2$ .

The proof of propositions 6.12 and 6.15 is involved in rather cumbersome combinatorial calculations, so we will not present it here, referring interested reader to works of Carmen Minguez [Minguez:1985], [Minguez:1988a], [Minguez:1988b]. Note that so far we have considered differential forms with values in some Euclidean  $R$ -module  $V$ . We can consider also a situation when there is a vector bundle  $p : E \rightarrow M$ , hence there is given the commutative diagram

$$\begin{array}{ccc} N^{D^n} & \xrightarrow{\omega} & E \\ \pi \downarrow & & \downarrow p \\ N & \xrightarrow{\phi} & M. \end{array} \quad (226)$$



**Definition 6.16** Let  $M$  and  $N$  be the microlinear spaces, let  $p : E \rightarrow M$  be the vector bundle, and let  $\phi : N \rightarrow M$  be some morphism. A **differential  $n$ - $\phi$ -form** or **differential  $n$ -form with values in vector bundle  $p$  relative to  $\phi$**  is the map  $\omega : N^{D^n} \rightarrow E$  such that for every  $i \in \{1, \dots, n\}$ ,  $\gamma \in M^{D^n}$ ,  $\lambda \in R$ :

1. (*n-homogeneity*)  $\omega(\lambda \cdot_i \gamma) = \lambda \omega(\gamma)$ ,
2. (*alternation*)  $\omega(\Sigma(\gamma)) = \text{sgn } \sigma \cdot \omega(\gamma)$ ,
3.  $\omega(\gamma) \in E_{\phi(0, \dots, 0)}$ .

The object of differential  $n$ - $\phi$ -forms with value in  $p$  is denoted as  $A^n(N \xrightarrow{\phi} M, p)$  or  $A^n(M, p)$ . For  $p : M \times R \rightarrow M$  (i.e. the **trivial bundle**) we use the notation  $A^n M$  instead of  $A^n(M, M \times R \rightarrow M)$ . Now we would like to define the notion of exterior derivative for differential  $n$ -forms with values in vector bundle. However, we cannot apply the definition (217), because in case of  $n$ - $\phi$ -forms although

$$\gamma_0^i(d_1, \dots, d_n) = \gamma(d_1, \dots, d_{i-1}, 0, d_i, \dots, d_n) \quad (227)$$

is an  $n$ -microcube centered at  $\gamma(0, \dots, 0)$ , the component

$$\gamma_1^i(d_1, \dots, d_n) = \gamma(d_1, \dots, d_{i-1}, h_i, d_i, \dots, d_n) \quad (228)$$

is not. Thus, we have to make a parallel transport of  $\omega(\gamma_1^i)$  by the infinitesimal distance  $h_i$  back along the direction of tangent vector  $\phi \circ \gamma_i$ , where  $\gamma_i(d) = \gamma(0, \dots, 0, d, 0, \dots, 0)$  is a vector tangent to  $N$  at  $\gamma(0, \dots, 0)$ . This means that instead of  $\omega(\gamma_0^i) - \omega(\gamma_1^i)$  we have to consider the difference  $\omega(\gamma_0^i) - q_{(\phi \circ \gamma_i, h_i)}^\nabla(\omega(\gamma_1^i))$ . Clearly, this involves the use of connection.

**Definition 6.17** The **exterior covariant derivative** or **exterior covariant differential** is the map

$$d_\nabla : A^n(N \xrightarrow{\phi} M, p) \rightarrow A^{n+1}(N \xrightarrow{\phi} M, p), \quad (229)$$

such that

$$h_1 \cdot \dots \cdot h_{n+1} \cdot d_\nabla \omega(\gamma) = \sum_{i=1}^{n+1} (-1)^i h_1 \cdot \dots \cdot \hat{h}_i \cdot \dots \cdot h_{n+1} (\omega(\gamma_0^i) - q_{(\phi \circ \gamma_i, h_i)}^\nabla(\omega(\gamma_1^i))). \quad (230)$$

We will see that the exterior covariant derivative of some forms gives familiar geometrical notions. Let's begin with the torsion.

**Definition 6.18** The **identity 1-form with value in tangent bundle of  $M$**

$$\begin{array}{ccc} M^D & \xrightarrow{\theta} & M^D \\ \pi \downarrow & & \downarrow \pi \\ M & \xrightarrow{\text{id}_M} & M \end{array} \quad (231)$$

is called the **canonical form**.

**Proposition 6.19**

$$d_\nabla \theta(\gamma) = C(\gamma) - C(\Sigma(\gamma)). \quad (232)$$

**Proof.**  $h_1 \cdot h_2 \cdot d_{\nabla} \theta(\gamma) = \sum_{i=1}^2 h_1 \cdot h_2 (\theta(\gamma_0^i) - \theta'(\gamma_1^i)) = -h_2(\theta(\gamma_0^1) - \theta'(\gamma_1^1)) + h_1(\theta(\gamma_0^2) - \theta'(\gamma_1^2))$ , where  $\gamma_0^1(d) = \gamma(0, d)$ ,  $\gamma_1^1(d) = \gamma(h_1, d)$ ,  $\gamma_0^2(d) = \gamma(d, 0)$ ,  $\gamma_1^2(d) = \gamma(d, h_2)$ ,  $\theta(\gamma_0^1) = \gamma_0^1$  and  $\theta(\gamma_0^2) = \gamma_0^2$ , thus, using the equation 133,

$$\theta'(\gamma_1^1) = q_{(\phi \circ \gamma_1, h_1)}^{\nabla}(\gamma_1^1) = q_{(\gamma_1, h_1)}^{\nabla}(\gamma_1^1) = q_{(\gamma_1, h_1)}^{\nabla}(\gamma(h_1, \cdot)) = V(\gamma)(h_1, \cdot) = \gamma(0, \cdot) + h_1 \cdot C(\gamma), \quad (233)$$

so

$$-h_2(\theta(\gamma_0^1) - \theta'(\gamma_1^1)) = -h_2(\gamma_0^1 - (\gamma_0^1 + h_1 C(\gamma))) = h_2 h_1 C(\gamma). \quad (234)$$

On the other hand, we get

$$\theta'(\gamma_1^2) = q_{(\phi \circ \gamma_2, h_2)}^{\nabla}(\gamma_1^2) = q_{(\gamma, h_2)}^{\nabla}(\gamma(\cdot, h_2)) = V(\gamma)(\cdot, h_2) = \gamma(\cdot, 0) + h_2 \cdot C(\Sigma(\gamma)), \quad (235)$$

thus

$$h_1 \cdot h_2 \cdot d_{\nabla} \theta(\gamma) = h_2 \cdot h_1 (C(\gamma) - C(\Sigma(\gamma))). \quad (236)$$

Cancelling  $h_1 \cdot h_2$  on both sides, we get

$$d_{\nabla}(\gamma) = C(\gamma) - C(\Sigma(\gamma)). \quad (237)$$

□

**Corollary 6.20** We have  $d_{\nabla} \theta((Y \cdot X)(m)) = T(X, Y)(m)$ , an call  $d_{\nabla} \theta$  the **torsion form** of the connection  $\nabla$  and denote it as  $\Theta$ .

**Remark 6.21** The connection map  $C : E^D \rightarrow E$  is an element of  $A^1(E \xrightarrow{p} M, p)$ , so it is an 1- $p$ -form called the **connection form** denoted as  $\omega$ .

$$\begin{array}{ccc} E^D & \xrightarrow{\omega} & E \\ \downarrow & & \downarrow p \\ R & \xrightarrow{p} & M. \end{array} \quad (238)$$

**Definition 6.22** The covariant exterior derivative of connection form is called the **curvature form** as is denoted as

$$\Omega := d_{\nabla} \omega. \quad (239)$$

**Proposition 6.23**

$$\Omega = C \circ C^D - C \circ C^D \circ \Sigma. \quad (240)$$

**Definition 6.24** Let  $\Omega$  be the curvature form. A **curvature or curvature tensor or Riemann-Christoffel tensor** is the map

$$R : M^D \times_M M^D \times_M M^D \rightarrow M^D \quad (241)$$

such that

$$R(X, Y, Z)(m) = \Omega((Z \cdot Y \cdot X)_m), \quad (242)$$

where

$$(Z \cdot Y \cdot X)_m(d_1, d_2)(d_3) := (Z_{d_3} \circ Y_{d_2} \circ X_{d_1})(m). \quad (243)$$

**Proposition 6.25**

$$R(X, Y, Z) = \nabla_X(\nabla_Y Z) - \nabla_Y(\nabla_X Z) - \nabla_{[X, Y]}(Z). \quad (244)$$

The *infinitesimal* proof of this proposition (such that is performed only on infinitesimals) is very long, although not complicated, and the same is in the case of the proposition 6.23. We will omit them, referring for details to the [Lavendhomme:1996]. However, we will turn back to these propositions later, when introducing the coordinates, and then we will show that such defined curvature tensor and curvature forms are really the same objects as classical differential objects defined under the same name (in particular, we will construct then also the coordinatized version  $R_{jkl}^i$  of the curvature tensor  $R$  using the infinitesimal parallel transport along the infinitesimal parallelogram).

**Corollary 6.26** *We have defined covariant derivative by the connection form*

$$\nabla_X Y := \omega(Y \cdot X), \quad (245)$$

*torsion by the torsion form*

$$T(X, Y) := \Theta(Y \cdot X), \quad (246)$$

*and curvature by the curvature form*

$$R(X, Y, Z) := \Omega(Z \cdot Y \cdot X), \quad (247)$$

*where  $\Theta$  and  $\Omega$  were defined as*

$$\begin{aligned} \Theta &:= d_{\nabla} \theta, \\ \Omega &:= d_{\nabla} \omega, \end{aligned} \quad (248)$$

*where  $d_{\nabla}$  is an exterior covariant derivative and  $\theta : TM \rightarrow TM$  is a canonical form.*

It is important to note, that Nishimura in [Nishimura:1997b] and [Nishimura:1998], using his calculus of three-dimensional strong infinitesimal difference, has proven the **Bianchi identities**:

$$\begin{aligned} d_{\nabla} \Theta &= \Omega \wedge \theta, & \text{(the first Bianchi identity)} \\ d_{\nabla} \Omega &= d_{\nabla} d_{\nabla} \omega = 0. & \text{(the second Bianchi identity)} \end{aligned} \quad (249)$$

The second Bianchi identity is true only for horizontal vectors taken into account, because they are exactly the same as those which can be used to make an infinitesimal parallel transport along the tangent bundle of microlinear space. In classical differential geometry the second Bianchi identity is also given for the horizontal vectors only (see [Kobayashi:Nomizu:1963]).

## 7 Axiomatic structure of the real line

In this section we will develop the axiomatic structure of the real line (modelled by the ring  $R$  with certain axioms imposed) to fit as precisely as possible to the natural presumptions that we make about real line, staying, however, in the category-theoretic and intuitionistic universe of discourse. So far we have established two axioms (the former was given implicitly):

**Axiom 0**  $\langle R, +, \cdot, 0, 1 \rangle$  *is a commutative ring with unit.*

**Axiom 1 (Kock-Lawvere)**  $\forall g \in R^D \quad \exists! b \in R \quad \forall d \in D \quad g(d) = g(0) + d \cdot b$ , where  $D := \{x \in R | x^2 = 0\} \subset R$ .

If we want to develop the differential geometry, the Kock-Lawvere axiom should be given in generalized version.

**Axiom 1 (generalized Kock-Lawvere)** For any Weil algebra  $R \otimes W$  there is an  $R$ -algebra isomorphism  $R \otimes W \cong R^{\text{Spec}_R(R \otimes W)}$ .

It is quite obvious that we would like to concern such rings  $R$  which are not trivial.

**Axiom R 1 (Non-triviality)**  $\neg(0 = 1)$ .

We have imposed that there is such  $D \subset R$  that  $d \in D \Rightarrow d^2 = 0$ , so the important question is: are there some not-nilpotent elements, such that  $x^2 \neq 0$ ,  $x \cdot y \neq 0$ , or even  $x \cdot y = 1$ ? (Note that these conditions are not equal, because we have  $\not\vdash \alpha \vee \neg\alpha$  for any naive-set-theoretical statement about elements of ring  $R$ .)

**Definition 7.1** An object of *invertible elements* in  $R$  is an object

$$\text{Inv } R := \{x \in R \mid \exists y \in R \ xy = 1\}. \quad (250)$$

To make the properties of  $R$  closer to these of the real line,<sup>21</sup> we will impose that it is a local ring, i.e. that the following axiom holds.

**Axiom R 2 (Local ring)**

$$\forall x \in R \quad x \in \text{Inv } R \quad \vee \quad x - 1 \in \text{Inv } R. \quad (251)$$

We have established locality, hence it is the right moment to introduce the ordering on  $R$ , in aim to compare its elements. Again, it should be done gently, keeping an eye on the intuitionistic logic of statements.

**Axiom R 3 (Order)** On  $R$  is given the order relation  $<$  such that, for every  $x, y \in R$ ,

1.  $<$  is transitive, i.e.  $(x < y \wedge y < z) \Rightarrow x < z$ ,
2.  $<$  is compatible with the ring structure, in sense that
  - (a)  $0 < 1$ ,
  - (b)  $(0 < x \vee x < 0) \iff x \in \text{Inv } R$ ,
  - (c)  $0 < x \Rightarrow \exists y \ (x = y^2)$ .

Note that the order  $<$  cannot be antisymmetric ( $\forall x, y \in R \ x < y \vee y < x$ ), because it would imply  $D = \{0\}$ , what is in contradiction with the Kock-Lawvere axiom. For any particular  $x$ , the order  $<$  creates two objects of  $R$ :

$$\begin{aligned} L_x &:= \{y \in R \mid y < x\}, \\ U_x &:= \{y \in R \mid x < y\}. \end{aligned} \quad (252)$$

---

<sup>21</sup>Note one crucial issue, that there is no platonic *real line*, the *proper line* – we just want to express some our ideas.

$R$  is not decidable, what means that for any statement  $\alpha$  about elements of  $R$  we have  $\not\vdash \alpha \vee \neg\alpha$ . Thus, we have to say that

$$\begin{aligned} &\not\vdash (y < x) \vee \neg(y < x), \\ &\not\vdash (y < x) \vee (x < y). \end{aligned} \quad (253)$$

This means that  $R$  cannot be decomposed into union of  $L_x$  and  $U_x$ :

$$R \neq L_x \cup U_x. \quad (254)$$

So, for a given  $x$  we cannot say that  $y \in U_x \vee y \in L_x$ . The situation imposed on the ring  $R$  by introduction of the order relation can be drawn as follows.

$$R = \text{-----} \begin{array}{c} < x \\ \text{)} \\ \end{array} \quad \begin{array}{c} \text{(} \\ > x \\ \text{-----} \end{array} \quad (255)$$

We may try to fill this gap by introducing the partial order relation  $\leq$ .

**Axiom R 4 (Preorder)** *On  $R$  is given the preorder relation  $\leq$  such that, for every  $d \in D$  and  $x, y, z \in R$ ,*

1.  $\leq$  is transitive and reflexive, i.e.

$$(a) (x \leq y \wedge y \leq z) \Rightarrow x \leq z,$$

$$(b) x \leq x.$$

2.  $\leq$  is compatible with the ring structure, in sense that

$$(a) 0 \leq 1 \wedge \neg(1 \leq 0),$$

$$(b) (0 \leq x \wedge 0 \leq y) \Rightarrow 0 \leq x \cdot y,$$

$$(c) x \leq y \Rightarrow x + z \leq y + z,$$

3.  $0 \leq d \wedge d \leq 0$ .

This axiom gives the picture

$$R = \text{-----} \begin{array}{c} \leq x \\ | \\ \geq x \end{array} \text{-----} \quad (256)$$

We may make now axioms R3 and R4 to be compatible with each other.

**Axiom R 5 (Compatibility of orderings)** 1.  $x < y \Rightarrow x \leq y$ ,

2.  $\neg(x < y \wedge y \leq x)$ .

and get the picture<sup>22</sup>

$$R = \left\{ \begin{array}{l} \text{---} \left. \begin{array}{l} < x \\ > x \end{array} \right\} \text{---} \\ \text{---} \left. \begin{array}{l} \leq x \\ \geq x \end{array} \right\} \text{---} \end{array} \right. \quad (257)$$

Using the partial order relation, we may define now the *closed interval*:

$$[a, b] := \{x \in R \mid a \leq x \leq b\}. \quad (258)$$

From the axiom R4.3, we have that

$$D \subset [0, 0]. \quad (259)$$

Moreover, we have  $[a + d_1, b + d_2] = [a, b]$ . In particular, it means that if  $x \in [a, b]$ , then  $x + d \in [a, b]$ . This means, that if we have defined some  $f(x)$  on  $x \in [a, b]$ , then  $f(x + d)$  given by the Kock-Lawvere axiom is also defined on  $[a, b]$ . Using the order relation, we can define now the *open interval*:

$$(a, b) := \{x \in R \mid a < x < b\}. \quad (260)$$

From the compatibility axiom we get

$$(a, b) \subseteq [a, b]. \quad (261)$$

It should be now noticed, that in previous sections we have developed axiomatic SDG using implicitly one more assumption, namely the existence of the object natural numbers  $N \subset R$ ,

### Axiom N 1 (Natural numbers)

$$\forall n \in N \quad \exists y \in R \quad n = y, \quad (262)$$

defined by the Peano axioms,

### Axiom N 2 (Peano axioms) 1. $0 \in N$ ,

$$2. \forall x \in R \quad (x \in N \Rightarrow x + 1 \in N),$$

$$3. \forall x \in R \quad \neg(x \in N \wedge x + 1 = 0),$$

such that  $R$  is Archimedean ring,

### Axiom N 3 (Archimedean ring)

$$\forall x \in R \quad \exists n \in N \quad x < n, \quad (263)$$

<sup>22</sup>Note that the axiom R5 could be given in a different way, for example in [Goldblatt:1979] and [Grinkevitch:1996a], [Grinkevitch:1996b] it is given as follows:

### Axiom R 5 (Compatibility of orderings – alternative version) 1. $\neg(x < y) \Rightarrow y \leq x$ ,

$$2. (x < y \wedge y \leq z) \Rightarrow x < z.$$

In fact, we work with intuitionistic logic where familiar laws of double negation and excluded middle do not hold, so we may give a range of slightly different axiomatics, each one expressing slightly different precognitions. Such slightly different axiomatics may lead sometimes to slightly or not-so-slightly different conclusions, so it is important, while working intuitionistically, to check the equality or non-provability of equality of statements which seem to be similar.

and for every statement  $\phi(n)$  involving  $n \in \mathbb{N}$  we have

**Axiom N 4 (Induction)**

$$\phi(0) \Rightarrow ((\forall n \in \mathbb{N} \ \phi(n) \Rightarrow \phi(n+1)) \Rightarrow \phi(n)). \quad (264)$$

At the beginning of this chapter it was said that existence of such infinitesimal objects like  $D$  in  $R$  neglects that  $R$  can be a field in classical meaning of this word. Now we should turn back to this theme, because there are really three notions of a field:

1.  $R$  is a **geometric field** if  $\forall x \in R \ x \in \text{Inv } R \vee x = 0$ ,
2.  $R$  is a **field of fractions** if  $\forall x \in R \ \neg(x \in \text{Inv } R) \Rightarrow x = 0$ ,
3.  $R$  is a **field of quotients** if  $\forall x \in R \ \neg(x = 0) \Rightarrow x \in \text{Inv } R$ .

They are equivalent when we use the Boolean logic, but nonequivalent when the double negation principle and the law of excluded middle do not hold, so in the intuitionistic logic. It means that in intuitionistic universe of discourse we can choose one of these definitions as most important, depending on this what we want to achieve.<sup>23</sup> Note now, that there are two ways of construction of *real* numbers: through the equivalence classes of sequences of rationals (this construction is known as **Cauchy reals**  $\mathbb{R}_C$ ) or, *alternatively*, by the sequences of splitting cuts (such construction gives the object called the **Dedekind reals**  $\mathbb{R}_D$ ). It can be shown (see [Johnstone:1977]) that there is an ‘inclusion’ (a monic map)  $\mathbb{R}_C \rightarrow \mathbb{R}_D$  in every such topos that both constructions may be performed (the minimal condition is the existence of natural numbers object  $\mathbb{N}$  in such topos<sup>24</sup>). It can be also shown, that  $\mathbb{R}_D$ , if it exists, is a field of fractions (see [Mulvey:1974]). In topos **Set** we have  $\mathbb{R}_D \cong \mathbb{R}_C$ , and all three notions of field coincide under the gently care of classical logic. More generally, it can be proven that  $\mathbb{R}_C \cong \mathbb{R}_D$  if and only if the topos is Boolean (again, see [Johnstone:1977] for details). In our situation of ring  $R$  modelled in some cartesian closed category or topos, we have such elements  $d \in D \subset R$  for which  $\not\vdash d = 0 \vee \neg(d = 0)$ , thus  $R$  has to be the field of quotients, and cannot be modelled (non-trivially) in any Boolean topos. This means also that  $R \not\cong \mathbb{R}_D$ .

**Axiom R 6 (Field of quotients)**

$$\forall x_1, \dots, x_n \in R \ \neg\left(\bigwedge_{i=1}^n (x_i = 0)\right) \Rightarrow \left(\bigvee_{i=1}^n (x_i \in \text{Inv } R)\right). \quad (265)$$

(The symbols  $\bigwedge$  and  $\bigvee$  denote the multiple conjunction and alternative, respectively.) We will moreover assume that  $R$  is a **formally real ring**.

**Axiom R 7 (Formally real ring)**

$$\forall x_1, \dots, x_n \in R \ \bigvee_{i=1}^n (x_i \in \text{Inv } R) \Rightarrow \left(\sum_{i=1}^n x_i^2\right) \in \text{Inv } R. \quad (266)$$

<sup>23</sup>Of course, as says Mulvey in [Mulvey:1974], *the answer to the question of which is the right definition to take for a field is that the question itself is not well-posed.*

<sup>24</sup>The natural number object  $\mathbb{N}$  in topos is not the same as the object of natural numbers  $N$  axiomatically introduced in SDG. These two notions may coincide under the interpretation ( $\mathbb{N}$  can be the interpretation of  $N$ ), but we should resist and refuse identification of them, because they live in two different worlds.

**Proposition 7.2**

$$\forall x \in R \quad x < 0 \vee (\forall n \in (N - \{0\}) \quad -\frac{1}{n} < x < \frac{1}{n}) \vee x > 0. \quad (267)$$

**Proof.** If  $x \in R$ , then  $x \in \text{Inv } R \vee x - 1 \in \text{Inv } R$ , what means that  $(x < 0 \vee x > 0) \vee (x < 1 \vee x > 1)$ , what is equal to  $x > 0 \vee x < 1$ . From this, for any  $n \in (N - \{0\})$ , we get  $x < y \vee y < x + \frac{1}{n}$ .  $\square$

If we will define the *object of infinitesimals*  $\Delta$  as

$$\Delta := \{x \in R \mid \forall n \in \mathbb{N} \quad -\frac{1}{n+1} < x < \frac{1}{n+1}\} \subset R, \quad (268)$$

then we may say, that the equation (267) provides the decomposition of  $R$ :

$$R = R_- \cup \Delta \cup R_+, \quad (269)$$

where  $R_- := \{x \in R \mid x < 0\}$  and  $R_+ := \{x \in R \mid x > 0\}$ . If we will impose that  $R$  is Pythagorean ring,

**Axiom R 8 (Pythagorean ring)**

$$\forall x_1, \dots, x_n \in R \quad (\text{sum}_{i=1}^n x_i^2) \in \text{Inv } R \Rightarrow \exists \left( \sqrt{\sum_{i=1}^n x_i^2} \right) \in \text{Inv } R, \quad (270)$$

then we can prove the following proposition

**Proposition 7.3**  $\Delta$  is a maximal ideal in  $R$ .

**Proof.** [Grinkevich [Grinkevich:1996a]] Let's take  $d \in \Delta$ ,  $r \in R$  and  $\varepsilon := \frac{1}{n+1} \forall n \in N$  (note that  $\varepsilon$  is defined for every  $n \in N$ ). This means that  $\varepsilon > 0$  and  $-\varepsilon < d < \varepsilon$ . By the equation (267) there are three cases:

1.  $r > 0$ , so  $r \in \text{Inv } R$ . This means that  $\varepsilon/r > 0$ , thus  $-\varepsilon/r < d < \varepsilon/r$  and  $-\varepsilon < d \cdot r < \varepsilon$ . So,  $d \cdot r \in \Delta$ ,
2.  $r < 0$  (this case is proven similarly),
3.  $-\varepsilon < r < \varepsilon$ .  $\varepsilon - r > 0$  and  $\varepsilon - d > 0$ , so  $(\varepsilon - r)(\varepsilon - d) = \varepsilon^2 - r\varepsilon - d\varepsilon + rd > 0$ . We will define  $\varepsilon' := \varepsilon^2 - r\varepsilon - d\varepsilon$ . We have  $dr > -\varepsilon'$ ,  $\varepsilon^2 > 0$  and  $\varepsilon r, \varepsilon d \in \Delta$  (because  $d, r \in \Delta$ ). This implies that  $\varepsilon' > 0$ . From the other hand  $\varepsilon(\varepsilon - d)/(\varepsilon + d) > 0$ , so  $\varepsilon(\varepsilon - d)/(\varepsilon + d) > r$ , and  $\varepsilon' = \varepsilon^2 - r\varepsilon - d\varepsilon > dr$ . Thus, we have  $-\varepsilon' < dr < \varepsilon'$ . At the end we will show that for any  $\varepsilon'$  we can find proper  $\varepsilon$ . We have a polynomial  $\varepsilon^2 - \varepsilon(d+r) - \varepsilon' = 0$ .  $R$  is Pythagorean ring, so we can use the standard calculation method, and receive  $\varepsilon = (d+r + \sqrt{(d+r)^2 + 4\varepsilon'})/2 > 0$ . This means that the quantifier  $\forall n \in N$  promotes from  $\varepsilon$  to  $\varepsilon'$ , and we have finally  $\forall n' \in N - \frac{1}{n'} < d \cdot r < \frac{1}{n'}$ , so  $d \cdot r \in \Delta$ .

From the equation (267) we have that  $R = \text{Inv } R \cup \Delta$ , thus any other ideal with nilpotent elements which contains  $\Delta$  is equal to  $R$ . Hence,  $\Delta$  is a maximal ideal.  $\square$



Thus, we have the sequence of inclusions

$$D \subset D_2 \subset \dots \subset D_n \subset \dots \subset D_\infty \subset [0, 0] \subset \mathbb{A}, \quad (271)$$

and we can write

$$\vdash x < 0 \vee x \in \mathbb{A} \vee x > 0. \quad (272)$$

but we still have the undecidability

$$\not\vdash x < 0 \vee x > 0, \quad (273)$$

and

$$\not\vdash x < r \vee r < x, \quad (274)$$

and

$$\not\vdash x < r \vee x = r \vee x > r. \quad (275)$$

$\mathbb{A}$  is a maximal ideal of  $R$ , so we can just divide  $R$  by  $\mathbb{A}$  and work with the elements of  $R/\mathbb{A}$ . However, this would hide from us all infinitesimal arithmetics, which is one of main advantages of SDG. Thus, we will go different way, ensuring the decidability of wide range of sentences by introducing the notion of **apartness**  $x\#y$ , which will be a useful substitute for not-very-useful assertion  $\neg(x = y)$ , because it will give us an ability to make use from the decidable sentence (272) instead of not decidable (275).

**Definition 7.4** We say that  $a, b \in R$  are **apart** and write  $a\#b$ , if  $a - b \in \text{Inv } R$ .

**Corollary 7.5**

$$a\#0 \Rightarrow a \in \text{Inv } R. \quad (276)$$

**Proposition 7.6** For all  $a, b, c \in R$ :

1.  $a = b \Rightarrow \neg(a\#b)$ ,
2.  $\neg(a = b) \iff a\#b$ ,
3.  $a\#b \Rightarrow ((a\#c) \vee (b\#c))$ ,
4.  $a\#b \Rightarrow (a + c)\#(b + c)$ ,
5.  $(a\#c) \wedge (c\#0) \Rightarrow a \cdot c\#b \cdot c$ ,
6.  $a \cdot b\#0 \Rightarrow (a\#0 \wedge b\#0)$ ,
7.  $a + b\#0 \Rightarrow (a\#0 \vee b\#0)$ ,
8.  $a \cdot b\#c \cdot d \Rightarrow (a\#c \vee b\#d)$ .

**Proof.**

1.  $a = b \Rightarrow a - b = 0 \Rightarrow \neg(a - b \in \text{Inv } R) \Rightarrow \neg a\#b$ ,
2.  $\neg(a = b) \iff \neg(a - b = 0) \Rightarrow (a - b \in \text{Inv } R) \Rightarrow a\#b$  (last  $\Rightarrow$  by the axiom R6), on the other hand  $a\#b \Rightarrow (a - b \in \text{Inv } R) \Rightarrow \neg(a - b = 0)$ ,
3.  $a\#b \Rightarrow (a - b \in \text{Inv } R)$ .  $R$  is a local ring, thus  $x \in \text{Inv } R \vee r - x \in \text{Inv } R$  for any  $x \in R$  and  $r \in \text{Inv } R$ . Taking  $r = a - b$  and  $x = a - c$ , we get  $a - c \in \text{Inv } R \vee c - b \in \text{Inv } R$ , thus  $a\#c \vee b\#c$ .

4.  $\wedge(a\#b) \Rightarrow \neg(a < b \vee a > b) \Rightarrow \neg(a \wedge b) \wedge \neg(a > b) \Rightarrow (a \geq b \wedge a \leq b)$ .
5.  $a\#b \iff (a < b \vee a > b) \Rightarrow (a + b < b + c \vee a + c > b + c) \Rightarrow (a + c\#b + c)$ .
6.  $(a\#b \wedge c\#0) \Rightarrow ((a < b \vee a > b) \wedge (c > 0 \vee c < 0))$ . For  $c > 0$  we get  $(ac < bc \vee ac > bc) \Rightarrow ac\#bc$ . Similarly for  $c < 0$ .
7.  $ab\#0 \Rightarrow (a\#0 \vee ab\#a)$ . If  $a\#0$  then  $a^{-1}\#0 \wedge (ab)a^{-1}\#0$ , so  $b\#0$ . If  $ab\#a$ , then  $a(b-1)\#0$ . From  $1\#0$  we get  $a\#0 \vee b-1\#0$ . If  $b\#0$ , then  $b^{-1}\#0$  and  $(ab)b^{-1}\#0$ ,  $a\#0$ . Similarly for  $b-1\#0$ .
8.  $a + b\#0 \Rightarrow b\# -a \Rightarrow (b\#0 \vee -a\#0)$ .
9. From  $ab - cd\#0$  and  $a(b-d) + d(a-c)\#0$  follows that  $b-d\#0 \vee a-c\#0$ .

□

## 8 Coordinates and formal manifolds

So far we have developed the system of differential geometry by fully coordinate-free method, what is admirable, because it corresponds to natural feelings of many geometers that coordinates are foundationally irrelevant. However, if we would like to establish more direct link between classical and differential geometry, it is unavoidable to introduce the coordinates. Recall that we have defined the vector space as such fibre  $E_x$  of a vector bundle  $E$ , which is a Euclidean  $R$ -module, i.e. an  $R$ -module which satisfies the Kock-Lawvere axiom:

$$\forall t \in E_x^D \exists!(v, u) \in E_x \times E_x \forall d \in D \quad t(d) = u + d \cdot v. \quad (277)$$

(In particular, it means that  $R^X$  is a vector space for any  $X$ .) Now we would like to introduce a basis in  $E_x$ , to have an ability to decompose any vector into the sum of countable (or even finite) elements. This would be done by maps from natural numbers.

**Definition 8.1** A *finite cardinal* is an object

$$[n] := \{m \in N \mid m < n + 1\} \subset N. \quad (278)$$

An object  $A$  is said to be *finite* if there exists an epic arrow ('surjection')  $[n] \twoheadrightarrow A$ .

**Definition 8.2** A *collection of vectors* of vector space  $V$  is a map  $X \rightarrow V$  from some decidable object  $X$ . A *finite collection of vectors* of vector space  $V$  is a map  $[n] \twoheadrightarrow V$  given by

$$N \supset [n] \ni \{1, \dots, n\} \xrightarrow{\{v_1, \dots, v_n\}} v \in V. \quad (279)$$

These two definitions ensure that we will work with decidable sequences of vectors (however, their values still may not be decidable!), what corresponds to our intuition of a 'vector' as being something decomposable into *decidable* directions. Formally, a finite collection of vectors is a map  $[n] \twoheadrightarrow V$ , thus an object  $\{v_1, \dots, v_n\} \in V^{[n]}$ , or an element of  $V$  at stage  $[n] : \{v_1, \dots, v_n\} \in_{[n]} V$ . We will however omit the superscript writing just  $\{v_1, \dots, v_n\} \in V$  or even  $v_1, \dots, v_n$ , in the same manner as we did it earlier with the collections  $\lambda_1, \dots, \lambda_n \in R$ .

**Definition 8.3** A *finite linear combination of vectors* is a sum  $\sum_{i=1}^n v_i$ , where  $v_i$  are the ('elements of') finite collection of vectors  $\{v_1, \dots, v_n\} \in V$ .

**Definition 8.4** A finite collection of vectors  $\{v_1, \dots, v_n\} \in V$  is said to

- **generate** the module  $V$  if

$$\forall v \in V \exists \lambda_1, \dots, \lambda_n \in R \sum_{i=0}^n \lambda_i v_i = v, \quad (280)$$

- be **linearly independent** in the module  $V$  if

$$\forall \lambda_1, \dots, \lambda_n \in R \left( \sum_{i=0}^n \lambda_i v_i = 0 \Rightarrow \forall i \lambda_i = 0 \right), \quad (281)$$

- be a **finite basis** if it generates the module  $V$  and is linearly independent in  $V$ . A number  $n$  is then called the **dimension** of a basis.

**Definition 8.5** An **apartness relation**  $\#$  on vector space  $V$  is such that for any  $a, b, c \in V$

1.  $a = b \Rightarrow \neg(a\#b)$ ,
2.  $\neg(a = b) \iff a\#b$ ,
3.  $a\#b \Rightarrow (a\#c \vee c\#a)$ .

**Definition 8.6** We say that a finite collection of vectors  $\{v_1, \dots, v_n\} \in V$  is

- **strongly linearly dependent** if

$$\exists \lambda_j \# 0 \sum_i \lambda_i v_i = 0, \quad (282)$$

- **mutually free** if

$$\exists \lambda_j \# 0 \Rightarrow \sum_i \lambda_i v_i \# 0. \quad (283)$$

**Proposition 8.7** If finite collection of vectors is linearly independent, then it is mutually free.

**Proof.** In the intuitionistic logic we have the rule  $(\alpha \Rightarrow \beta) \Rightarrow (\neg\beta \Rightarrow \neg\alpha)$ . By taking  $\alpha := (\sum_{i=0}^i \lambda_i v_i = 0)$  and  $\beta := (\forall_j \lambda_j = 0)$ , we have  $((\sum_{i=0}^i \lambda_i v_i = 0) \Rightarrow (\forall_j \lambda_j = 0)) \Rightarrow (\neg(\forall_j \lambda_j = 0) \Rightarrow \neg(\sum_{i=0}^i \lambda_i v_i = 0)) \Rightarrow ((\exists_j \lambda_j \# 0) \iff (\sum_{i=1}^n \lambda_i v_i \# 0))$ . The last step is done using the fact that  $\neg(a = b) \iff (a\#b)$ .  $\square$

**Corollary 8.8** A basis in  $V$  is a finite collection of mutually free vectors such that every vector in  $V$  can be expressed as a finite combination of vectors from this collection.

**Proposition 8.9** Any two basis in  $V$  have the same dimension.

**Proof.** [Grinkevich [Grinkevich:1996a]] Let  $\{v_1, \dots, v_p\}$  be a basis in  $V$ , and let  $p \geq 1$ . We should show that if any other basis  $\{w_1, \dots, w_r\}$  has  $r$  elements, then  $r \leq p$  and  $p \leq r$ . We may write

$$w_1 = c_1 v_1 + \dots + c_p v_p, \quad (284)$$

where  $c_1, \dots, c_p \in R$ . We have  $w_1 \neq 0$ , because  $\{w_1, \dots, w_r\}$  are mutually free. Assuming that  $\forall_i c_i = 0$  leads to contradiction, so true is  $\neg(\bigwedge_{i=1}^p c_i = 0)$ . From the axiom R6 we get that  $\exists_i c_i \neq 0$ . Let's take that  $i = 1$ , so  $c_1 \neq 0$ . Then  $v_1$  lays in the space generated by a finite collection  $\{w_1, v_2, \dots, v_p\}$ . We will show that this collection is a basis of  $V$ , i.e. they are mutually free. Consider a linear combination  $\lambda_1 w_1 + \sum_{i=2}^p \lambda_i v_i$  such that  $\exists_i \lambda_i \neq 0$ . Using (284) we get

$$\lambda_1 c_1 v_1 + \sum_{i=2}^p (\lambda_i + c_i \lambda_1) v_i. \quad (285)$$

There are two cases for  $\lambda_1$ :

1.  $\lambda_1 \neq 0$ . In this situation  $\lambda_1 c_1 \neq 0$ , because  $c_1 \neq 0$ .
2.  $\lambda_1 \in \mathbb{A}$ . In this situation  $\lambda_1 c_i \in \mathbb{A}$ , thus  $\lambda_i + c_i \lambda_1 \neq 0$ .

In any case, under assumption of mutual freedom of  $\{v_1, \dots, v_p\}$ , we get apartness of (285), hence mutual freedom of  $\{w_1, v_2, \dots, v_p\}$ . The rest part of proof is performed by an induction. Inverse inequality is proven similarly.  $\square$

Apartness is a strong notion which 'cuts off' infinitesimals from the equations, making them *decidable* (in both senses – of intuitionistic logic and of linear algebra) and it can be used to perform constructive proofs. We have introduced basis in  $R$ -modules, but we would like also to have local isomorphism between any tangent or vector bundle on microlinear space and  $R^n$ . Thus, we would like to express categorially the notion of local diffeomorphism. To achieve it, we should take some open covering of  $N$  by a family of  $N_\alpha \subseteq N$  diffeomorphic to open subobjects of  $R^n$ , i.e.  $\sqcup_\alpha N_\alpha \rightarrow N$  and  $N_\alpha \rightarrow R^n$ .

**Definition 8.10** *An arrow  $f : M \rightarrow N$  between any two objects  $M$  and  $N$  is **formal étale** if for any small object  $\text{Spec}_R W$  and the canonical map*

$$\mathbf{1} \xrightarrow{0} \text{Spec}_R W, \quad (286)$$

*called the **base point** of small object, the diagram*

$$\begin{array}{ccc} M^{\text{Spec}_R W} & \xrightarrow{f^{\text{Spec}_R W}} & N^{\text{Spec}_R W} \\ \downarrow M^0 & & \downarrow N^0 \\ M^1 & \xrightarrow{f} & N^1 \end{array} \quad (287)$$

*is a pullback.*

**Proposition 8.11** *Arrows  $D_\infty^n \rightarrow R^n$  and  $\text{Inv } R \rightarrow R^n$  are formal étale.*

**Proof.**

1. Straight from the fact that the product of formal étale arrows is formal étale.

2. First we will prove that

$$\begin{array}{ccc} \text{Inv } W & \xrightarrow{\quad} & W \cong R^n \\ \downarrow & & \downarrow \pi_1 \\ \text{Inv } R & \longrightarrow & R \end{array} \quad (288)$$

is a pullback (where  $W$  is a Weil algebra). Let us take some  $\{v_1, \dots, v_n\} = v \in W$ , such that  $v_1 \in \text{Inv } R$ . It means that we can divide  $v$  by  $v_1$ , achieving  $\{v_1, v_2, \dots, v_n\}$ . Now, let us take some other vector  $u \in W$ , such that  $u$  is in ideal of  $W$ , for example  $u = -\{0, v_2, \dots, v_n\}$ . This means that  $u^n = 0$  and  $v = 1 - u$ . Hence, we get  $(1 - u) \cdot (1 + u + u^2 + \dots + u^{n+1}) = 1$ , which means that  $v \in \text{Inv } R$ , thus (288) is a pullback. Now we can use the generalized Kock-Lawvere axiom and the fact that  $(-)^X$  preserves limits, and get that the diagram

$$\begin{array}{ccc} \text{Inv } (R^{\text{Spec}_R W}) & \xrightarrow{\quad} & R^{\text{Spec}_R W} \\ \downarrow & & \downarrow \\ \text{Inv } R & \longrightarrow & R \end{array} \quad (289)$$

is a pullback, hence a pullback also is

$$\begin{array}{ccc} (\text{Inv } R)^{\text{Spec}_R W} & \xrightarrow{\quad} & R^{\text{Spec}_R W} \\ \downarrow & & \downarrow \\ \text{Inv } R & \xrightarrow{\quad} & R. \end{array} \quad (290)$$

□

**Proposition 8.12** *Class  $\mathcal{D}$  of formal étale arrows has following properties:*

1.  $\mathcal{D}$  is closed under compositions and has all isomorphisms.
2. Inverse arrows of elements of  $\mathcal{D}$  belong to  $\mathcal{D}$ .
3. If  $v \in \mathcal{D}$  and the diagram

$$\begin{array}{ccc} \cdot & \xrightarrow{\quad} & \cdot \\ v \downarrow & & \downarrow u \\ \cdot & \xrightarrow{\quad g \quad} & \cdot \end{array} \quad (291)$$

is a pullback, then  $u \in \mathcal{D}$ .

4. Epic and monic composites from epi-mono-factorization of an arrow from  $\mathcal{D}$  belong to  $\mathcal{D}$ .
5. If  $p$  is epic,  $p \in \mathcal{D}$  and  $g \circ p \in \mathcal{D}$ , then  $g \in \mathcal{D}$ .

**Proposition 8.13** *If  $M$  is microlinear and  $p : M \twoheadrightarrow N$  is an regular epic<sup>25</sup> and formal étale, then  $N$  is microlinear. If  $N$  is microlinear and  $p : M \rightarrow N$  is monic and formal étale, then  $M$  is microlinear.*

We will not prove here those two propositions, referring reader in first case to [Kock:1981] and in second to [Kock:Reyes:1979a].

<sup>25</sup>A **regular epic** is a such epic that is a coequalizer.

**Definition 8.14** If  $U \rightarrow R^n$  is monic and formal étale, then  $U$  is called an ***n-dimensional model object***.

**Definition 8.15** A ***formal n-dimensional manifold*** is such  $M$  that there exists a regular epic arrow  $\sqcup_i U_i \rightarrow M$  (i.e. a ***covering family*** by jointy epic class of arrows) for a family of monic and formal étale maps  $U_i \rightarrow M$  such that every  $U_i$  is *n-dimensional model*.

**Proposition 8.16** 1. Any formal manifold is microlinear.

2. If  $M$  is formal manifold, then  $TM = M^D$  is formal manifold.

3. If  $U$  is model object, then  $TU = U^D$  is a formal manifold.

4. If  $M$  is *n-dimensional formal manifold*, then  $T_x M \cong R^n$  for every  $x \in M$ .

**Proof.**

1. Straight from the proposition 8.13 and the definition of a formal manifold, by ‘tracing back’ microlinearity from  $R^n$  by the monic formal étale, and ‘pushing forward’ by regular epic formal étale.
2. Comes from easy to prove fact that if outside and right rectangles in the diagram

$$\begin{array}{ccccc} \cdot & \longrightarrow & \cdot & \longrightarrow & \cdot \\ \downarrow & & \downarrow & & \downarrow \\ \cdot & \longrightarrow & \cdot & \longrightarrow & \cdot \end{array} \quad (292)$$

are pullbacks, then left square is pullback too. So, as the functor  $(-)^X$  preserves pullbacks, the top square in the diagram

$$\begin{array}{ccc} M^{\text{Spec}_R W^{\text{Spec}_R W}} & \xrightarrow{f^{\text{Spec}_R W^{\text{Spec}_R W}}} & N^{\text{Spec}_R W^{\text{Spec}_R W}} \\ M^{00} \downarrow & & \downarrow N^{00} \\ M^{\text{Spec}_R W} & \xrightarrow{f^{\text{Spec}_R W}} & N^{\text{Spec}_R W} \\ M^0 \downarrow & & \downarrow N^0 \\ M^1 & \xrightarrow{f} & N^1 \end{array} \quad (293)$$

is a pullback.

3. By the virtue of proof above and the proposition (8.13).
4. From (287) we have the pullback

$$\begin{array}{ccc} X & & \\ \downarrow & \searrow & \\ U^D & \longrightarrow & (R^n)^D \cong R^n \times R^n \\ \downarrow & & \downarrow \pi_1 \\ U & \longrightarrow & R^n. \end{array} \quad (294)$$

$\pi_1$  is unique by the Kock-Lawvere axiom, hence we get the product diagram

$$\begin{array}{ccc}
 & X & \\
 & \vdots & \\
 & U^D & \\
 \swarrow & & \searrow \\
 U & \xrightarrow{\quad} & R^n,
 \end{array} \tag{295}$$

thus  $U^D \cong U \times R^n$ . For a given  $x$  we get  $U_x^D \cong R^n$ . The transition to  $T_x M$  is given by a regular epic  $\sqcup_i (U_x^D)_i \rightarrow T_x M$  (which is formal étale by the second point of the recent proof).

□

**Definition 8.17** Let  $\{U_i \xrightarrow{\varphi_i} M\}$  be a covering of formal manifold  $M$  by a family of local étale monic arrow  $\varphi_i$ , where  $U_i$  are model objects. A pair  $(U_i, \varphi_i)$  is called a **local card** on  $M$ .

Consider now two local cards:  $(U, \varphi)$  and  $(V, \psi)$ . Recall that we work in some topos, so we have a pullback

$$\begin{array}{ccc}
 U \cap V & \longrightarrow & U \\
 \downarrow & & \downarrow \varphi \\
 V & \xrightarrow{\psi} & M
 \end{array} \tag{296}$$

and epi-mono-factorization

$$\begin{array}{ccc}
 U & \xrightarrow{\varphi} & M \\
 \searrow & & \swarrow \\
 & \varphi(U) &
 \end{array} \tag{297}$$

From the properties of class of étale maps, we get that  $U \cap V \rightarrow M$  is a formal étale and monic arrow, and  $\varphi^{-1} : \varphi(U) \rightarrow U$  is formal étale isomorphism. So, if  $U \cap V$  is not empty, then there is a **change of model** map  $\varphi \circ \psi : V \rightarrow U$  which is monic and formal étale.

**Definition 8.18** We say that microlinear space is **parallelizable** if there is a fibrewise  $R$ -linear isomorphism  $\varphi$ , such that the diagram

$$\begin{array}{ccc}
 M^D & \xrightarrow{\varphi} & M \times V \\
 \searrow & & \swarrow \\
 & M &
 \end{array} \tag{298}$$

commutes for some  $R$ -module object  $V$ .

**Corollary 8.19** Any  $n$ -dimensional formal manifold  $M$  is a microlinear space parallelizable by the  $R$ -module object  $R^n$  through the local card. Every such parallelization is called a **local coordinate system**.

For now on we will simplify the notation for finite collections of vectors denoting  $(v_1, \dots, v_n) := \{v_1, \dots, v_n\}$ . Consider a local card  $(U, \varphi)$ , where  $U \subseteq R^n$  and  $\varphi^{-1}(m) = (0, \dots, 0)$  for some

$m \in M$ . For some tangent vector  $v \in T_m M$  (thus, such  $v$  that  $v : D \rightarrow M$  and  $v(0) = m$ ) we have that  $\varphi^{-1} \circ v : D \rightarrow U$  is a vector tangent to  $U$  with a base point  $(0, \dots, 0)$ . We have  $TU \cong U \times R^n$  and  $\varphi^{-1} \circ v(d) = (0, \dots, 0) + d(v_1, \dots, v_n)$  for  $(v_1, \dots, v_n) \in R^n$ . We will denote as  $\partial_i$  or  $\frac{\partial}{\partial x^i}$  or  $e_i$  such vectors that

$$\partial_i(d) = (0, \dots, 0) + d \cdot (0, \dots, 0, \overset{i}{1}, 0, \dots, 0). \quad (299)$$

Vectors  $\partial_i \circ \varphi$  form basis  $(\partial_1 \circ \varphi, \dots, \partial_n \circ \varphi)$  in  $T_m M$ . We will usually abuse this notation by writing just  $(\partial_1, \dots, \partial_n)$ .

**Definition 8.20** *Two vectors  $a, b \in R^n$  are said to be **apart**, and denoted  $a \# b$  if for some  $i$  their coefficients  $a_i, b_i \in R$  are apart  $a_i \# b_i$  in the sense of the apartness on  $R$ .*

**Proposition 8.21** *Apartness on  $R^n$  defined above is the same apartness which was defined for any  $R$ -module  $V$ .*

**Proof.** It suffices to check the conditions given for apartness on  $V$ .

1. Obvious.
2. In one direction it is obvious. Second direction comes straight from the axiom R6.
3. Let  $a, b, c \in R^n$  and  $a \# b$ , i.e. exists such  $i$  that  $a_i \# b_i$ . Then we have  $a_i \# c_i \vee c_i \# b_i$ , thus  $a \# c \vee c \# a$ .

□

**Corollary 8.22** *We will say that vectors  $u, v \in T_m M$  are **apart** if  $\varphi^{-1} \circ u \# \varphi^{-1} \circ v$  in  $T_{(0, \dots, 0)} U$ .*

Now we would like to introduce a dual basis in the space of the  $(k-)$ linear forms. It seems easy, but we have also to establish a direct link between basis from vector space and the basis from the space of linear forms (covector space). In classical linear algebra it is done by introducing the Kronecker delta symbol:

$$\delta_j^i := \begin{cases} 0 & \iff i \neq j, \\ 1 & \iff i = j, \end{cases} \quad (300)$$

and by defining the **dual basis**  $\{f^1, \dots, f^n\}$  of the space of linear forms as

$$f^i(e_j) := \delta_j^i, \quad (301)$$

where  $e_j$  are the elements of the basis of the corresponding vector space. However, we are working in the smooth and intuitionistic framework, and so we should not use such functions like (300). Thus, we have to ‘emulate’ intuitionistically the Kronecker delta by something smooth, imposing the following axiom.

### Delta Axiom

There exists a **delta function**  $\delta : R \rightarrow R$  such that

$$\delta := \begin{cases} x = 0 & \implies \delta(x) = 1, \\ x \geq 1 \vee x \leq -1 & \implies \delta(x) = 0. \end{cases} \quad (302)$$

and defining

$$\delta_j^i := \delta(i - j). \quad (303)$$



Now the definition (301) of the basis  $f^i$  in the space of linear forms is correct. We could propose an alternative definition

$$\delta := \begin{cases} x = 0 & \Rightarrow \delta(x) = 1, \\ x \# 0 & \Rightarrow \delta(x) = 0, \end{cases} \quad (304)$$

but it would be incorrect, since such  $\delta(x)$  would not be smooth, as it would have not enough ‘space’ in order to move smoothly from 0 in 0 to 1 in  $\#0$ . The infinitesimal distance is undecidable, but it does not mean that it is large!

With the definitions given above, we may, systematically using the apartness relation, build the system of intuitionistic linear algebra. However, in this work we are interested only in expressing vectors and forms in bases in coordinate-involved manner, so for more exhaustive development of intuitionistic linear algebra we refer reader to the works of Heyting [Heyting:1941], [Heyting:1971] and Grinkevich [Grinkevich:1996a], [Grinkevich:1996b]. As an application of introduced above notions of local coordinates, basis, and elements of intuitionistic linear algebra, we will now ‘coordinate’ the connection and curvature on a formal manifold.

Consider  $n$ -dimensional formal manifold with connection  $\nabla$  on the tangent bundle  $M^D \rightarrow M$ . For some model object  $U \mapsto R^n$  the tangent bundle is modeled by  $U^D \rightarrow U$ , and connection becomes a map

$$U^D \times_U U^D \cong U \times R^n \times R^n \xrightarrow{\nabla} U \times R^n \times R^n \times R^n \cong U^{D \times D}. \quad (305)$$

This map is completely determined by the last component, because  $\nabla$  is a section of

$$K : U \times R^n \times R^n \times R^n \rightarrow U \times R^n \times R^n \quad (306)$$

such that

$$K : (u, v_1, v_2, v_3) \mapsto (u, v_1, v_2). \quad (307)$$

For (305) we can write the operations  $\oplus$  and  $+$  in  $(U^D)^D \cong U^{D \times D}$  as

$$(u, v'_1, v'_2, v'_3) \oplus (u, v''_1, v''_2, v''_3) = (u, v'_1 + v''_1, v'_2 + v''_2, v'_3 + v''_3) \quad (308)$$

and

$$(u, v_1, v'_2, v'_3) + (u, v_1, v''_2, v''_3) = (u, v_1, v'_2 + v''_2, v'_3 + v''_3). \quad (309)$$

The multiplication by scalars is given similarly. We will define the last component of an image of  $\nabla$  as  $\bar{\nabla}$ , i.e.

$$\nabla(u, v_1, v_2) =: (u, v_1, v_2, \bar{\nabla}(u, v_1, v_2)). \quad (310)$$

If the affine connection is symmetric, then  $\bar{\nabla}(u, v_1, v_2)$  is bilinear in  $v_1, v_2$ . We define the **components of connection** or **Christoffel symbols** as

$$\Gamma_{ij}^\ell := \bar{\nabla}(\cdot, \cdot, \cdot)^{\ell, i, j}. \quad (311)$$

This means that

$$\Gamma_{ij}^k(x) = \bar{\nabla}(x, e_i, e_j)(e_k). \quad (312)$$

A pair of vectors  $v_1, v_2$  at base point  $u$  may be denoted as a map  $D(2) \rightarrow U$  such that

$$(d_1, d_2) \mapsto u + d_1 v_1 + d_2 v_2. \quad (313)$$

The connection  $\nabla$  associates to this map a map in  $D \times D \rightarrow U$  given by

$$(d_1, d_2) \mapsto u + d_1 v_1 + d_2 v_2 + d_1 d_2 \bar{\nabla}(u, v_1, v_2) = (u + d_1 v_1) + d_2 \cdot (v_2 + d_1 \bar{\nabla}(u, v_1, v_2)). \quad (314)$$

The vector  $v_2 + d_1 \bar{\nabla}(u, v_1, v_2)$  is a result of parallel transport of  $v_2$  along  $v_1$  by  $d_1$ , while  $u + d_1 v_1$  is its base point. The connection map  $C$  was defined as a difference between a vector in  $U^{D \times D} \cong U \times R^n \times R^n \times R^n$  and its horizontal part:

$$(u, v_1, v_2, v_3) \mapsto v_3 - \bar{\nabla}(u, v_1, v_2). \quad (315)$$

We have expressed  $\nabla$  and  $C$  in coordinates, so we can do the same with curvature tensor defined as

$$\Omega := C \circ C^D - C \circ C^D \circ \Sigma. \quad (316)$$

Considering two vectors  $v_1, v_2$  in base point  $u$ , we can take some vector  $v_3$  and transport it parallelly, first along  $v_1$  by  $d_1$  and next along  $v_2$  by  $d_2$ , or first along  $v_2$  by  $d_2$  and next along  $v_1$  by  $d_1$ . The difference between result of these two transports is exactly the action of curvature expressed in (316). We can express now (316) using coordinates, particularly using (314). Transport of  $v_3$  along  $v_1$  by  $d_1$  and next along  $v_2$  by  $d_2$  gives the vector

$$v_3 + d_1 \cdot \bar{\nabla}(u, v_1, v_3) + d_2 \cdot \bar{\nabla}(u + d_1 v_1, v_2, v_3 + d_1 \cdot \bar{\nabla}(u, v_1, v_3)) \quad (317)$$

attached at  $u + d_1 v_1 + d_2 v_2$ , while the transport along  $v_2$  by  $d_2$  and next along  $v_1$  by  $d_1$  gives the vector

$$v_3 + d_2 \bar{\nabla}(u, v_2, v_3) + d_1 \cdot \bar{\nabla}(u + d_2 v_2, v_1, v_3 + d_2 \cdot \bar{\nabla}(u, v_2, v_3)) \quad (318)$$

attached at the same point. We may now use the Taylor's formula (41), considering  $\bar{\nabla}(\cdot, -, =)$  as a function of the first variable only. In such case, equations (317) and (318) become respectively:

$$v_2 + d_1 \cdot \bar{\nabla}(u, v_1, v_2) + d_2 \cdot (\bar{\nabla}(u, v_2, v_3) + d_2 \cdot \partial_{v_1} \bar{\nabla}(u, v_2, v_3) + d_1 \cdot \bar{\nabla}(u, v_2, \bar{\nabla}(u, v_1, v_3))), \quad (319)$$

and

$$v_2 + d_2 \cdot \bar{\nabla}(u, v_2, v_3) + d_1 \cdot (\bar{\nabla}(u, v_1, v_3) + d_2 \cdot \partial_{v_2} \bar{\nabla}(u, v_1, v_3) + d_2 \cdot \bar{\nabla}(u, v_1, \bar{\nabla}(u, v_2, v_3))), \quad (320)$$

where  $\partial_{v_2} \bar{\nabla}$  denotes the derivative of the function  $\bar{\nabla}$  calculated with respect to  $v_2$  only. The difference between them is

$$d_1 d_2 (\partial_{v_1} \bar{\nabla}(u, v_2, v_3) + \bar{\nabla}(u, v_2, \bar{\nabla}(u, v_1, v_3)) - \partial_{v_2} \bar{\nabla}(u, v_1, v_3) - \bar{\nabla}(u, v_1, \bar{\nabla}(u, v_2, v_3))). \quad (321)$$

We may take now  $v_1, v_2, v_3$  as vectors of the canonical base  $e_i, e_j, e_k$  and get, using the bilinearity of  $\nabla(u, -, =)$ , the familiar expression on curvature tensor:

$$R_{kji}^\ell(u) := R((u, e_i), (u, e_j), (u, e_k))_\ell = \frac{\partial}{\partial x_i} \Gamma_{jk}^\ell(u) - \frac{\partial}{\partial x_j} \Gamma_{ik}^\ell(u) + \sum_\alpha \Gamma_{ik}^\alpha(u) \cdot \Gamma_{j\alpha}^\ell(u) - \sum_\alpha \Gamma_{jk}^\alpha(u) \cdot \Gamma_{i\alpha}^\ell(u), \quad (322)$$

and

$$R_{kji}^\ell(x) = \frac{\partial}{\partial x_i} \Gamma_{jk}^\ell(x) - \frac{\partial}{\partial x_j} \Gamma_{ik}^\ell(x) + \sum_\alpha \Gamma_{ik}^\alpha(x) \cdot \Gamma_{j\alpha}^\ell(x) - \sum_\alpha \Gamma_{jk}^\alpha(x) \cdot \Gamma_{i\alpha}^\ell(x). \quad (323)$$

Note that the introduction of local coordinates gives us the ability to use many of classical definitions, propositions and proofs in SDG. We could introduce coordinates earlier, but it would not have any sense, because our intention and aim was to show that in SDG we can develop theory on a more abstract and at the same time more fundamental level. Now, after establishing the foundational framework, we would like to express the familiar results of classical differential geometry in the familiar language of coordinates. In particular, many of *constructive* definitions, propositions and proofs from the book of Kobayashi and Nomizu [Kobayashi:Nomizu:1963] can be used in our context with no doubts. (Of course, it should be done keeping gently eye on the cross-dependencies between various notions and methods of particular proofs.) For example, we can import into SDG the propositions §III.7.2-§III.7.5.

**Proposition 8.23** (Kobayashi and Nomizu, §III.7.2) *Let  $\nabla$  be a connection on  $M$ . Let  $\Gamma_{jk}^i$  be the components of  $\nabla$  for some basis  $(x^1, \dots, x^n)$  and model object  $U$ , and let  $\bar{\Gamma}_{jk}^i$  be the components of  $\nabla$  for some basis  $(\bar{x}^1, \dots, \bar{x}^n)$  and model object  $V$ . On the intersection  $U \cap V$  we have transformation rule*

$$\bar{\Gamma}_{\beta\gamma}^\alpha = \sum_{i,j,k} \Gamma_{jk}^i \frac{\partial x^j}{\partial \bar{x}^\beta} \frac{\partial x^k}{\partial \bar{x}^\gamma} \frac{\bar{x}^\alpha}{\partial x^i} + \sum_i \frac{\partial^2 x^i}{\partial x^\gamma \partial \bar{x}^\gamma} \frac{\partial \bar{x}^\alpha}{\partial x^j}. \quad (324)$$

**Proposition 8.24** (Kobayashi and Nomizu, §III.7.3) *Suppose that for every local coordinate system  $(x^1, \dots, x^n)$  we have a family of maps  $\Gamma_{jk}^i$  which satisfy (324). Then there exists a unique connection  $\nabla$  such that its components are given by  $\Gamma_{jk}^i$  in the coordinate system  $(x^1, \dots, x^n)$ .*

In the context of SDG this statement is obvious by the construction, and it does not need any special proof. Next two propositions are also expressible in SDG without any doubts.

**Proposition 8.25** (Kobayashi and Nomizu, §III.7.4) *Let  $(x^1, \dots, x^n)$  be local coordinate system on  $M$  equipped with the connection  $\nabla$ . We will put  $X_i = \partial_i = \frac{\partial}{\partial x^i}$  for  $i \in [n]$ . Then the components  $\Gamma_{jk}^i$  for  $\nabla$  are given by*

$$\nabla_{X_j} X_i = \sum_k \Gamma_{ji}^k X_k. \quad (325)$$

**Proposition 8.26** (Kobayashi and Nomizu, §III.7.5) *Consider a map  $\mathcal{X}(M) \times \mathcal{X}(M) \rightarrow \mathcal{X}(M)$ , denoted as  $(X, Y) \mapsto \nabla_X Y$ , such that it satisfies the conditions from proposition 4.12. Then there exists a unique connection  $\nabla$  on  $M$  such that  $\nabla_X Y$  is a covariant derivative defined by the connection map of  $\nabla$ .*

These propositions are easy to prove in the context of SDG, second one by the uniqueness of connection map  $C$  of connection  $\nabla$ , and the unique definition of  $\Gamma_{ji}^k$  through  $C$  and  $\nabla$  given earlier.

## 9 Riemannian structure

**Definition 9.1** *A classical linear 2-form  $g : M^D \times_M M^D \rightarrow R$  on a formal manifold  $M$  is called:*

- *symmetric* if  $g(v, w) = g(w, v)$ ,
- *nondegenerate* if  $\begin{cases} v \neq 0 & \Rightarrow g(v, v) > 0, \\ v = 0 & \Rightarrow g(v, v) = 0, \end{cases}$
- *nonnegative* if  $g(v, v) \geq 0$ .

*A symmetric nonnegative nondegenerate classical linear 2-form is called a **Riemannian structure** or a **metric tensor**.*

**Definition 9.2** *A **norm** of a vector  $v \in TM$  such that  $v \neq 0$  is defined as*

$$\|v\| := \sqrt{g(v, v)}. \quad (326)$$

Using some local coordinate system with base  $e^i$  we can write

$$g = \sum_{i,j} g_{ij} e^i \otimes e^j, \quad (327)$$

and so

$$g(u, v) = \sum_{i,j} g_{ij} e^i \otimes e^j(u, v) = \sum_{i,j} g_{ij} e^i(u) \otimes e^j(v) = \sum_{i,j} g_{ij} u^i v^j. \quad (328)$$

This means that for any  $x \in M$  we can take  $u, v \in T_x M$  and for  $\varphi^{-1}(x) = (0, \dots, 0)$  we have

$$g_{ij} = g(\partial_i, \partial_j), \quad g(u, v) = \sum_{i,j} g_{ij} u^i v^j, \quad (329)$$

where  $v^i$  and  $u^i$  are coordinates of vectors  $u$  and  $v$  in the basis  $\partial_i$ . It can be proven, using the intuitionistic linear algebra (see [Grinkevich:1996a]), that  $\det(g_{ij}) \neq 0$ .

**Definition 9.3** A *metrical connection* or *Levi-Civita connection*  $\Gamma$  on  $M$  is such connection that the parallel transport  $p_{(t,d)}^\Gamma(g)$  of a metric  $g$  does not change it.

**Proposition 9.4** The torsion free Levi-Civita connection is unique and satisfies the equation

$$\Gamma g = 0. \quad (330)$$

**Proof.** Let  $\bar{g} \in (R^{M^D \times_M M^D})^D$  such that  $g = \bar{g}(0)$  and  $g = \bar{g}(d)$  for every  $d \in D$ . Then, from the equation of the parallel transport (133) applied to  $\bar{g}$ , we get that  $C(\bar{g})$ , where  $C$  is the connection map associated to  $\Gamma$ , has to be equal to zero. This means that  $C(g \cdot X) = 0$  for any  $X \in M^D$ , thus  $\Gamma_X g = 0$ , so  $\Gamma g = 0$ . Consider now the connection  $\nabla$  on  $M$  given by the equation

$$2g(\nabla_X Y, Z) := X \cdot g(Y, Z) + Y \cdot g(X, Z) - Z \cdot g(X, Y) + g([X, Y], Z) + g([Z, X], Y) + g(X, [Z, Y]). \quad (331)$$

It is easy to check that such defined map  $(X, Y) \mapsto \nabla_X Y$  satisfies the properties given in the proposition 4.12. By the proposition 8.26 we get that such  $\nabla_X Y$  uniquely determines a connection  $\nabla$ . By the same constructive arguments as presented in [Kobayashi:Nomizu:1963], we can prove that the metrical connection on a formal manifold is unique (cf. op. cit., theorem §IV.2.2, proof B).  $\square$

**Corollary 9.5** (Kobayashi and Nomizu, §IV.2.4) In the terms of local coordinate system  $(x^1, \dots, x^n)$  the components of  $\Gamma_{jk}^i$  of a metrical connection  $\Gamma$  are such that

$$\sum_l g_{lk} \Gamma_{jk}^l = \frac{1}{2} \left( \frac{\partial g_{ki}}{\partial x^j} + \frac{\partial g_{jk}}{\partial x^i} + \frac{\partial g_{ji}}{\partial x^k} \right). \quad (332)$$

Thus, we have established the classically well-known objects  $g_{ij}$ ,  $\Gamma_{ij}^k$  and  $R_{ijk}^l$  in the synthetic context. For now on we will assume that we work only with the Levi-Civita connections. We can define now the

$$\text{Ricci tensor} \quad R_{kl} := R_{kil}^i, \quad (333)$$

the

$$\text{curvature scalar} \quad R := g^{kl} R_{kl}, \quad (334)$$

and the

$$\mathbf{Einstein\ tensor} \quad G_{ij} := R_{ij} - \frac{1}{2}Rg_{ij}. \quad (335)$$

Using the standard calculations on the coordinates, it can be shown that from the tensor version of Bianchi identities

$$\nabla_m R_{kij}^l = 0, \quad (336)$$

through the contraction of indices,

$$\begin{cases} \nabla_m (R_{jil}^i - R_{jli}^i) = 0, \\ g^{jl} \nabla_m (R_{jil}^i - R_{jli}^i) = 0, \end{cases} \quad (337)$$

it follows that

$$\nabla_j (R^{ij} - \frac{1}{2}Rg^{ij}) = 0. \quad (338)$$

Thus, we have

$$\nabla^j G_{ij} = 0. \quad (339)$$

Moreover, straight from the equation (330) we get that  $\nabla^j (g_{ij}\Lambda) = 0$  for any constant scalar value  $\Lambda$ , so

$$\nabla^j (G_{ij} + g_{ij}\Lambda) = \nabla^j (R_{ij} - \frac{1}{2}g_{ij}(R - 2\Lambda)) = 0. \quad (340)$$

Other properties of  $R_{jkl}^i$ ,  $R_{ij}$ ,  $R$  and  $G_{ij}$  are the same as in the classical differential geometry, and can be proven by the same calculations.

## 10 Some additional structures

The system of Synthetic Differential Geometry can be extended in many directions, and we do not intend to present here the comprehensive treatment of all areas. Thus, we will leave untouched such fields of development as principal fibre bundles, integration, variational calculus, topology, theory of solving of differential equations, theory of distributions, general actions, symplectic framework and hamiltonian as well as lagrangian formalism, although they all are developed in SDG (however, on different level of progress, in some areas still under construction). In this section we would like only to show a couple of definitions and axioms, namely of the curves, velocity and acceleration fields, geodesics, axiom of integration and perform a short discussion about topology.

**Definition 10.1** *Let  $p : E \rightarrow M$  be a vector bundle. A **curve** in  $E$  or a **vector curve** is a map  $X : \mathbb{R} \rightarrow E$ . The **derivative** of the curve  $X$  is the curve  $\frac{DX}{dt} : \mathbb{R} \rightarrow E$  such that*

$$\frac{DX}{dt}(x) = C(d \mapsto X(x+d)). \quad (341)$$

$\frac{DX}{dt}(x)$  is unique by the uniqueness of the connection map. We have also  $p \circ X = p \circ \frac{DX}{dt}$  and, by the properties of the connection map,

$$\begin{aligned} \frac{D(X+Y)}{dt}(x) &= \frac{DX}{dt}(x) + \frac{DY}{dt}(x), \\ \frac{D(f \cdot X)}{dt}(x) &= f'X(x) + f \cdot \frac{DX}{dt}(x), \\ \frac{D(X \circ f)}{dt}(s) &= f' \frac{DX}{dt}(f(x)). \end{aligned} \quad (342)$$

**Definition 10.2** The *velocity field* of a curve  $a : R \rightarrow M$  is a map  $\dot{a} : R \rightarrow M^D$  such that  $\dot{a}(t)(d) = a(t + d)$ . The *acceleration field* is a map  $\ddot{a} : R \rightarrow M^{D \times D}$  such that  $\ddot{a}(t)(d_1, d_2) = a(t + d_1 + d_2)$ . A curve  $a$  is called a *geodesic curve* with respect to connection  $\nabla$  if

$$\nabla(\dot{a}, \dot{a}) = \ddot{a}. \quad (343)$$

From these definitions we get that for a geodesic curve

$$\frac{D\dot{a}}{dt} = C \circ \ddot{a} = \ddot{a} \cdot \nabla K(\ddot{a}) = \ddot{a} \cdot \nabla(\dot{a}, \dot{a}) = 0. \quad (344)$$

In other words, the geodesic curve is *straight* in the sense of the connection  $\nabla$ .

So far we have developed such differential geometrical objects like tensor, vector and tangent bundles, vector fields, connections, differential forms, Lie derivatives and brackets, inner product, covariant derivative, exterior derivative, exterior covariant derivative, torsion and curvature. All these notions were defined *infinitesimally*, and their properties were also investigated on infinitesimal level. However, from physical point of view, we are interested mostly in *local*, i.e. *measurable* objects and observables. We should specify then the rule of transfer from infinitesimal to local level. This means that we have to *add* to our axiomatic system an *axiom of transfer* between these two levels. This axiom should manage the local structure which we *intend* to observe. Speaking more precisely: it is our *choice*, what particular *local* structure of space (or space-time) we impose. This choice may come from our presumptions, such like ‘the spacetime is partially ordered’. Once chosen local structure (or, better to say, the structure of local structure) determines partially the axiom of transfer, because imposes several properties on the codomain of transfer. As we intend to give the axiom of transfer between infinitesimal and local levels of calculus, called the *axiom of integration*, we have to specify the conditions imposed on local structure of space, which in SDG is modelled by the ring  $R$ . This have been done earlier by introducing several axioms (R1-R8) of the ring structure. Now we are ready to give the integration axiom.

### Integration Axiom

$$\forall f \in R^{[0,1]} \exists! g \in R^{[0,1]} \forall x \in [0,1] \exists! g' \in R^R \forall h \in D \quad g'(x) = f(x) \wedge g(0) = 0 \wedge g(x+h) = g(x) + f \cdot g'(x). \quad (345)$$

Such  $g$  is denoted as

$$g(x) =: \int_0^x f(t) dt. \quad (346)$$

The axiom given above has to be compatible with the orderings  $<$  and  $\leq$ . This is imposed by two following axioms:

#### Axiom I2 (Compatibility of $\int$ and $<$ )

$$\forall x \in [0,1] \quad f(x) > 0 \Rightarrow \int_0^1 f(x) dx > 0. \quad (347)$$

#### Axiom I3 (Compatibility of $\int$ and $\leq$ )

$$\forall x \in [0,1] \quad f(x) \geq 0 \Rightarrow \int_0^1 f(x) dx \geq 0. \quad (348)$$

The following axiom forces the existence of the inverse function:

#### Axiom I4 (Inverse function)

$$\forall f \in R^R \quad \forall x \in R \quad f'(x) \in \text{Inv } R \Rightarrow \exists U, V \subset R \text{ (open subsets) such that } x \in U \wedge f(x) \in V. \quad (349)$$

These axioms are sufficient to develop the integral calculus, and are the basic tool to promote all our statements from the infinitesimal to local level (see [Moerdijk:Reyes:1991] for details).

Note that so far we have not spoken about topology. A topology of the real line is a kind of mathematical structure, so it can be given by some axioms which later can be interpreted in some universe of discourse. We have said ‘a topology of the real line’ and not ‘a topology’, because we wish to concern the *geometrical* objects as primary to the mathematical additional structures. It means that the interpretation of topological axioms of the real line may vary from one universe of discourse (topos) to another. Moreover, there can be valuable universes of discourse which do not hold the axioms of topological structure, but nonetheless they can have interesting differential geometric structure! We will give here only the topological axioms in the pure form and with a minimal discussion of this topic. In fact, the subject of topology in topos is *very* wide area, because toposes were born from the category of sheaves over topological space and so they are in precise sense natural universes to talk about topology. The so-called Grothendieck topology is one of the central ideas when talking about topology in topos, but, as said earlier, we will leave this for further considerations. The topology  $\mathcal{O}(R)$  on the real line  $R$  is imposed in SDG by the following axioms:

**Axiom T1 (Compactness)** *For every open cover  $\mathcal{U}$  of the closed interval  $[0,1]$  there is a finite collection  $[n] \xrightarrow[\{U_1, \dots, U_n\}]{} \gg \mathcal{O}([0,1])$  which refines  $\mathcal{U}$ .*

**Axiom T2 (Open refinement)**

$$\forall F \in \mathcal{P}([0,1])^N (\forall x \exists n \ x \in F_n \Rightarrow \forall x \in R \exists U \in \mathcal{O}([0,1]) \exists n \in N \ x \in U \subset F_n). \quad (350)$$

So-called well-adapted models of SDG, what means such toposes which allow to compare the classical differential geometry with synthetic one, have also a natural Grothendieck topology (which is categorically defined property). In such case the Grothendieck topology at the stage **1** is the same as set-theoretical point-topology. On other stages we get the topology which may be called ‘pointless’, because its basic entity are open covers defined on the space, where  $x$  is no longer a set-theoretic global element (point) but some generalized element, varying over stages. It means that on the one hand topology appears in SDG by the additional (not obligatory) axioms, and then can be modelled in some models, while on the other hand the wide range of well-adapted models of SDG has its own Grothendieck topology, which can be used in synthetic differential geometry by imposing the axioms which enable our system to *see* this topological structure of a model. However, in both cases we do not *need* to concern the topology when talking about such geometrical objects like vector bundles, differential forms and connections. And thus, we will leave this subject open for future considerations.

## 11 Well-adapted topos models

SDG is built on the axiomatic base. These axioms can be interpreted in different categories. Every such interpretation of axioms of SDG in a particular category is called a *model* of SDG. By the obvious reasons, we are at most interested in such models of SDG which allow to compare the ‘classical’ analytic post-Cauchy-Weierstassian differential geometry with synthetic one. At the beginning of this chapter we have considered that we develop SDG in some, not precised, cartesian closed category. Later, by introducing the generalized Kock-Lawvere axiom, we have restricted the class of categories available to development of SDG only to these, which have finite colimits. So, we have to work in cocomplete cartesian closed category. But the fact, that we would like to interpret the intuitionistic logic of statements somehow ‘naturally’ inside this category, forces us to take an assumption that we work in topos, thus in the complete and cocomplete cartesian

closed category with subobject classifier. For now on we will consider only toposes as models of SDG.

The first, simplest example of a model of SDG is  $\mathbf{Set}^{\mathbf{R}\text{-Alg}}$ , the topos whose objects are functors from a category  $\mathbf{R}\text{-Alg}$  of (finitely presented)<sup>26</sup>  $\mathbf{R}$ -algebras to the category  $\mathbf{Set}$  of sets:

$$\mathbf{R}\text{-Alg} \xrightarrow{R} \mathbf{Set}. \quad (351)$$

Each such functor is a forgetful functor, which associates to an  $\mathbf{R}$ -algebra the set of its elements, and to every homomorphism  $f$  of  $\mathbf{R}$ -algebras the same  $f$  as function on sets.

**Proposition 11.1** *A functor  $R \in \text{Ob}(\mathbf{Set}^{\mathbf{R}\text{-Alg}})$  is a commutative ring with unit.*

**Proof.** For every  $A \in \text{Ob}(\mathbf{R}\text{-Alg})$  we have a ring  $R(A)$ , together with operations of addition  $+_A : R(A) \times R(A) \rightarrow R(A)$  and multiplication  $\cdot_A : R(A) \times R(A) \rightarrow R(A)$ , which are natural in the sense, that they are preserved by the homomorphisms in  $\mathbf{R}\text{-Alg}$ , thus also by the corresponding functors  $\mathbf{R}\text{-Alg} \rightarrow \mathbf{Set}$ . This induces naturally the operations on  $R$ .  $\square$

Thus, we have shown that the functor  $R \in \text{Ob}(\mathbf{Set}^{\mathbf{R}\text{-Alg}})$  is a commutative ring (with unit). This  $R$  will be a model of a synthetic real line  $R$  considered in the previous chapter. An object  $D \subset R$  has the following interpretation in  $\mathbf{Set}^{\mathbf{R}\text{-Alg}}$ :

$$\mathbf{R}\text{-Alg} \ni A \xrightarrow{D} D(A) = \{a \in A \mid a^2 = 0\}. \quad (352)$$

This construction may seem very esotherical at first, but in fact it strictly expresses the difference and the link between our *concepts* and their *models*. Our concepts are formulated in abstract and ‘background-free’ way: as some relations between elements. For example, the *concept* of a sphere  $S^2$  (called an algebraic *locus*) is

$$S^2 = \{(x, y, z) \mid x^2 + y^2 + z^2 = 1\}. \quad (353)$$

We may now take different backgrounds to express  $S^2$ , for example saying that elements of  $S^2$  should belong to some (commutative) algebra, thus, to some object in the category  $\mathbf{R}\text{-Alg}$ . We would like however to ‘see’ somehow ‘naturally’ how such sphere  $S^2$ , expressed in terms of  $\mathbf{R}\text{-Alg}$ , ‘looks like’ (these words are in parthenenses to show where our presumptions are hidden. This leads us to demand that  $S^2$  should give as an output the set of triples of elements of  $A \in \text{Ob}(\mathbf{R}\text{-Alg})$  which satisfy the ‘conditions’ given in the definition of  $S^2$ . Thus,  $S^2$  becomes a set-valued *functor* from  $\mathbf{R}\text{-Alg}$  to  $\mathbf{Set}$ .

$$\mathbf{R}\text{-Alg} \ni A \longmapsto S^2(A) \in \mathbf{Set}. \quad (354)$$

So, the *interpretation* of the locus  $S^2$  in  $\mathbf{Set}^{\mathbf{R}\text{-Alg}}$  is

$$\mathbf{R}\text{-Alg} \ni A \xrightarrow{S^2} S^2(A) = \{(x, y, z) \in A^3 \mid x^2 + y^2 + z^2 = 1\} \in \mathbf{Set}, \quad (355)$$

which means that  $S^2$  is considered as a functor which takes those elements from the ring  $A$  which fit to a pattern  $x^2 + y^2 + z^2 = 1$ , and produces a set which contains them. For now on we will consider the case  $\mathbf{R} = \mathbb{R}$ , where  $\mathbb{R}$  is the well-known classical field of the real numbers (i.e. the object  $\mathbb{R} := \mathbb{R}_C = \mathbb{R}_D$  in a Boolean topos  $\mathbf{Set}$ ). Note that the global elements of  $R(A)$  are the arrows  $\mathbf{1} \rightarrow R(A)$ , thus  $\{*\} \rightarrow R(A)$ , because we are working in  $\mathbf{Set}$  (of course, the

<sup>26</sup>We will assume that all algebras and rings considered in this section are finitely presented.



fact that  $R(A) \in \text{Ob}(\mathbf{Set})$  is true also in the general case when  $\mathbf{R}$  is *some* ring). The  $\mathbb{R}$ -algebra corresponding to  $\{*\}$  is the  $\mathbb{R}$ -algebra with one generator  $\mathbb{R}[X]$ , and the arrow corresponding to  $\mathbf{1} \xrightarrow{\lceil x \rceil} R(A)$  is an  $\mathbb{R}$ -algebra homomorphism  $\mathbb{R}[X] \xrightarrow{\phi_x} A$ . This means that

$$R(A) \cong \mathbb{R}\text{-Alg}(\mathbb{R}[X], A), \quad (356)$$

i.e. that  $R$  is a representable functor, and we have

$$R \cong \text{Hom}(\mathbb{R}[X], -). \quad (357)$$

By the Yoneda Lemma it means also that

$$\text{Hom}(R, R) \cong \text{Nat}(\text{Hom}(\mathbb{R}[X], -), \text{Hom}(\mathbb{R}[X], -)) \cong \text{Hom}(\mathbb{R}[X], \mathbb{R}[X]), \quad (358)$$

so the maps  $f : R \rightarrow R$  on the ring  $R$  (from the synthetic point of view) are the maps of polynomials with coefficients in  $\mathbb{R}$  (from the interpretational point of view). It can be shown (see [Kock:1981] for details), that  $\mathbf{Set}^{\mathbb{R}\text{-Alg}}$  satisfies the generalized Kock-Lawvere axiom (and some weak version of integration axiom), but it does not satisfy any other axioms of SDG. Thus, we will move now to more appropriate models of SDG.

Consider the ring of smooth functions  $f : \mathbb{R}^n \rightarrow \mathbb{R}$  and the ring of smooth functions  $g : \mathbb{R}^m \rightarrow \mathbb{R}$ . We can define a category of rings of smooth functions with such arrows that preserve the smooth structure. Thus, if we denote the object of ring of smooth functions  $f : \mathbb{R}^n \rightarrow \mathbb{R}$  by  $C^\infty(\mathbb{R}^n, \mathbb{R})$  or just as  $C^\infty(\mathbb{R}^n)$ , then the composition which preserves the smooth maps is given by

$$\begin{aligned} C^\infty(h) : C^\infty(\mathbb{R}^k, \mathbb{R})^n &\rightarrow C^\infty(\mathbb{R}^k, \mathbb{R})^m, \\ (g_1, \dots, g_n) &\longmapsto h \circ (g_1, \dots, g_n). \end{aligned} \quad (359)$$

To make such rings of smooth functions into the category, we have to define smooth homomorphisms between them as

$$\begin{aligned} C^\infty(\varphi, \mathbb{R}) : C^\infty(X \subseteq \mathbb{R}^n, \mathbb{R}) &\rightarrow C^\infty(Y \subseteq \mathbb{R}^m, \mathbb{R}), \\ \varphi : X &\rightarrow Y. \end{aligned} \quad (360)$$

We can generalize these terms and define the category  $C^\infty$  of  $C^\infty$ -*rings* (or  $C^\infty$ -*algebras*) as a category of such rings  $A$  that are equipped with the additional structure given by the map  $\mathbb{R} \rightarrow A$  such that the compositions (as well as identities and projections  $\mathbb{R}^n \rightarrow \mathbb{R}$  of the smooth maps  $\mathbb{R}^n \xrightarrow{f} \mathbb{R}^m$  are preserved by  $A^n \xrightarrow{A(f)} A^m$ . These are the arrows of category of  $C^\infty$ -rings and are called the  $C^\infty$ -*homomorphisms*. The category *dual* to the category of (finitely generated)  $C^\infty$ -rings is denoted as  $\mathbf{L}$  (so,  $\mathbf{L}^{op} \equiv (C^\infty)_{FG}$ ).<sup>27</sup> Note that  $\mathbb{R}[X_1, \dots, X_k]$  was the (finitely generated) free  $\mathbb{R}$ -algebra with  $k$  generators being the projections. Similarly  $C^\infty(\mathbb{R}^k, \mathbb{R}) = C^\infty(\mathbb{R}^k)$  is a free  $C^\infty$ -ring with  $k$  generators as projections. As a next example of  $C^\infty$ -rings we can consider the (classical) manifold  $M$  of class  $C^\infty$  and the ring of all  $\mathbb{R}$ -valued smooth functions on this manifold, the  $C^\infty$ -ring  $C^\infty(M, \mathbb{R})$ . We can also divide some  $C^\infty$ -ring by an ideal  $I$ , and get another  $C^\infty$ -ring  $C^\infty(X)/I$ .<sup>28</sup> Another important example of  $C^\infty$ -ring is a ring of *germs* of smooth functions.

<sup>27</sup>Note that  $\mathbf{R}\text{-Alg}$  was defined as a category of arrows  $f_A : \mathbf{R} \rightarrow A$ , where  $\mathbf{R}$  and  $A$  are some commutative rings, such that  $xy = yx$  for every  $x \in f_A(\mathbf{R})$  and for every  $y \in \mathbf{R}$ . Following this definition, we may consider the category  $\mathbb{R}\text{-Alg}$  of  $\mathbb{R}$ -algebras as the category of rings  $A$  equipped with the additional structure given by the map  $\mathbb{R} \rightarrow A$  and with the maps  $A^n \xrightarrow{A(p)} A^m$  preserving the structure of polynomials  $p = (p_1, \dots, p_n) : \mathbb{R}^n \rightarrow \mathbb{R}^m$  in such way that identities, projections and compositions are preserved:  $A(\text{id}) = \text{id}$ ,  $A(\pi) = \pi$  and  $A(p \circ q) = A(p) \circ A(q)$ . So, the constructions of  $\mathbb{R}$ -algebras and  $C^\infty$ -rings are similar.

<sup>28</sup>From the Hadamard lemma for functions  $f : \mathbb{R} \rightarrow \mathbb{R}$  and  $g_i : \mathbb{R}^n \times \mathbb{R}^n \rightarrow \mathbb{R}$ , where  $i \in [n]$ , we have that  $f(x) - f(y) = \sum_{i=1}^n (x_i - y_i)g_i(x, y)$  for  $x = \{x_1, \dots, x_n\}$  and  $y = \{y_1, \dots, y_n\}$ , where  $x, y \in \mathbb{R}^n$ . This means that  $A(f)(x) - A(f)(y) = \sum_{i=1}^n (x_i - y_i)A(g_i)(x, y)$  for some  $C^\infty$ -ring  $A$ . If we take now  $(x_i - y_i) = 0 \text{ mod } I$  (where  $I$  is the ideal), then  $A(f)(x) - A(f)(y) = 0 \text{ mod } I$ . Thus,  $C^\infty$ -rings divided by an ideal are  $C^\infty$ -rings.

**Definition 11.2** A *germ* at  $x \in \mathbb{R}^n$  is an equivalence class of such  $\mathbb{R}$ -valued functions which coincide on some open neighbourhood  $U$  of  $x$ , and is denoted as  $f|_x$  for some  $f : U \rightarrow \mathbb{R}$ . We denote a ring of germs at  $x$  as  $C_x^\infty(\mathbb{R}^n)$ . If  $I$  is an ideal, then  $I|_x$  is the object of germs at  $x$  of elements of  $I$ .

Of course,  $C_x^\infty(\mathbb{R}^n)$  is a  $C^\infty$ -ring and  $I|_x$  is an ideal of  $C_x^\infty(\mathbb{R}^n)$ . The *object of zeros*  $Z(I)$  of an ideal  $I$  is defined as

$$Z(I) = \{x \in \mathbb{R}^n \mid \forall f \in I \quad f(x) = 0\}. \quad (361)$$

We may introduce the notion of *germ-determined ideal* as such  $I$  that

$$\forall f \in C^\infty(\mathbb{R}^n) \quad \forall x \in Z(I) \quad f|_x \in I|_x \Rightarrow f \in I. \quad (362)$$

The *dual* to the full subcategory of (finitely generated)  $C^\infty$ -rings whose objects are of form  $C^\infty(\mathbb{R}^n)/I$  such that  $I$  is germ-determined ideal is denoted by  $\mathbf{G}$  (we take the *dual* category, because we want to make a topos of presheaves  $\mathbf{Set}^{\mathbf{G}^{op}}$ , where sets will be varying on the (finitely generated)  $C^\infty$ -rings and not on their duals).<sup>29</sup> Now we can turn back to interpreting the SDG, recalling that for  $\mathbb{R}$ -algebras we have used the functor

$$\mathbb{R}\text{-Alg} \ni A \longmapsto R(A) \in \mathbf{Set}, \quad (363)$$

as the model (interpretation) of the naive-SDG ring  $R$  in the topos  $\mathbf{Set}^{\mathbb{R}\text{-Alg}}$ . In the same way we may define the interpretation of the ring  $R$  in the topos  $\mathbf{Set}^{\mathbf{G}^{op}}$ :

$$\mathbf{G}^{op} \ni A \longmapsto R(A) \in \mathbf{Set}. \quad (364)$$

The topos  $\mathbf{Set}^{\mathbf{G}^{op}}$  of presheaves over the category of germ-determined  $C^\infty$ -rings equipped with the Grothendieck topology is called the *Dubuc topos*, and is denoted by  $\mathcal{G}$ .<sup>30</sup> This topos is not only very good well-adapted model of SDG, but it also has a good representation of classical paracompact  $C^\infty$ -manifolds. More precisely,

**Proposition 11.3** *The real line  $R$  interpreted as a functor object in the topos  $\mathcal{G}$  satisfies generalized Kock-Lawvere axiom, as well as axioms R1-R8, N1-N4, Delta Axiom and integration axioms (and other not mentioned here). Moreover, there is a full and faithful covariant embedding  $s$  from the category  $\mathbf{Man}^\infty$  of paracompact  $C^\infty$ -manifolds to the topos  $\mathcal{G}$  which transforms open coverings into covering families.*

**Proof.** See [Moerdijk:Reyes:1991].  $\square$

For some purposes we can also use the larger topos  $\mathbf{Set}^{\mathbf{L}^{op}} := \mathbf{Set}^{C^\infty}$ . It does not have the interpretation for an axiom R2 of local ring and an axiom N3 of Archimedean ring, but it is a good toy-model, easier to concern than  $\mathcal{G}$  is. Note that the equation (356):

$$R(A) \cong \mathbb{R}\text{-Alg}(\mathbb{R}[X], A) \quad (365)$$

has an analogue in case of the interpretation of SDG in topos  $\mathbf{Set}^{\mathbf{L}^{op}}$ :

$$R(\ell A) \cong \mathbf{Set}^{\mathbf{L}^{op}}(\ell A, \ell C^\infty(\mathbb{R})), \quad (366)$$

<sup>29</sup>Thus, we have  $\mathbf{G} \subset \mathbf{L}$  and  $\mathbf{G}^{op} \subset \mathbf{L}^{op} \subset C^\infty$  as well as  $\mathbf{Set}^{\mathbf{G}^{op}} \subset \mathbf{Set}^{\mathbf{L}^{op}} \subset \mathbf{Set}^{C^\infty}$ .

<sup>30</sup>More precisely, the topos  $\mathcal{G}$  is a subcategory of  $\mathbf{Set}^{\mathbf{G}^{op}}$  obtained by sheafification, and we have an inclusion  $\mathcal{G} \hookrightarrow \mathbf{Set}^{\mathbf{G}^{op}}$ . The left adjoint  $a : \mathbf{Set}^{\mathbf{G}^{op}} \rightarrow \mathcal{G}$  is called the *sheafification functor*. In other words,  $\mathcal{G}$  is the topos of *sheaves* on  $\mathbf{G}$ .

where  $\ell C^\infty(\mathbb{R})$  is the  $C^\infty$ -ring (the symbol  $\ell$  denotes here the fact, that we are working within the category which is dual to that of  $C^\infty$  rings). Thus, a real line of an axiomatic SDG becomes now

$$R \cong \text{Hom}_{\mathbf{Set}^{\mathbf{L}^{op}}}(-, \ell C^\infty(\mathbb{R})), \quad (367)$$

or, using the formal logical sign which denotes interpretation in the model,

$$\mathbf{Set}^{\mathbf{L}^{op}} \models R \cong \text{Hom}_{\mathbf{Set}^{\mathbf{L}^{op}}}(-, \ell C^\infty(\mathbb{R})). \quad (368)$$

This means that the element of ring  $R$ , the real number of naive intuitionistic set theory, is some morphism  $\ell A \rightarrow \ell C^\infty(\mathbb{R})$ . We say that we have a **real at stage**  $\ell A$ . Thus, our *concept* of the real line  $R$  of Synthetic Differential Geometry can be *modelled (interpreted)* by the different rings (stages) of smooth functions on the *classical* space  $\mathbb{R}^n$  (which can be, however, defined categorically, as an  $n$ -ary product of an object  $\mathbb{R}_D$  of Dedekind reals in the Boolean topos  $\mathbf{Set}$ ). For example, at the stage  $\ell A = C^\infty(\mathbb{R}^n)/I$ , where  $I$  is some ideal of the ring  $C^\infty(\mathbb{R}^n)$ , a *real (real variable, real number)* is an equivalence class  $f(x) \bmod I$ , where  $f \in C^\infty(\mathbb{R}^n)$ . An interpretation of the most important (naive) objects of SDG is following [Moerdijk:Reyes:1991]:

smooth real line	$R = Y(\ell C^\infty(\mathbb{R})) = s(\mathbb{R})$
point	$\mathbf{1} = Y(\ell(C^\infty(\mathbb{R})/(x))) = s(\{*\}) = \{x \in R   x = 0\}$
first-order infinitesimals	$D = Y(\ell(C^\infty(\mathbb{R})/(x^2))) = \{x \in R   x^2 = 0\}$
$k^{\text{th}}$ -order infinitesimals	$D_k = Y(\ell(C^\infty(\mathbb{R})/(x^{k+1}))) = \{x \in R   x^{k+1} = 0\}$
infinitesimals	$\Delta = Y(\ell C_0^\infty(\mathbb{R})) = \{x \in R   \forall n \in \mathbb{N} \quad -\frac{1}{n+1} < x < \frac{1}{n+1}\}$

The symbol  $Y$  denotes the Yoneda functor  $\text{Hom}(-, \ell A) =: Y(\ell A)$ , while  $s$  denotes the functor<sup>31</sup>  $s : \mathbf{Man}^\infty \rightarrow \mathbf{Set}^{\mathbf{L}^{op}}$ , introduced in the proposition 11.3 (the symbol  $Y$  is often omitted, so one writes  $\ell C^\infty(\mathbb{R})/I$  instead of  $Y(\ell C^\infty(\mathbb{R})/I)$ ).

It seems that the ‘heaven of total smoothness’ of SDG should be somehow paid for. And indeed, it is. The simplification of a structure of geometrical theory raises the complication of its interpretation: we have to construct special toposes for interpreting SDG, going beyond set theory and the topos  $\mathbf{Set}$ . However, such complication may unexpectedly become a solution of many of our problems. Particularly, the well-adapted model  $\mathcal{G}$  of SDG is a topos of functors from (sheafified germ-determined duals of)  $C^\infty$ -rings to  $\mathbf{Set}$ , which means that we express differential geometry not in terms of points on manifold, but through such smooth functions on it, which have the same *germ*, what means that they coincide on some neighbourhood. In the Dubuc topos  $\mathcal{G}$  we have the interpretation (identification):

$$\boxed{\text{the real line } R \cong \text{a functor } R : C^\infty \supset \mathbf{G}^{op} \longrightarrow \mathbf{Set}}$$

A functor  $R$  is representable by the  $C^\infty$ -ring  $\ell C^\infty(\mathbb{R})$ , what means that

$$R \cong \text{Hom}(-, \ell C^\infty(\mathbb{R})). \quad (369)$$

The *real*  $x$  at stage  $\mathbf{1}$ , thus a global element of a real line  $R$ , is given in the axiomatic system by

$$x \in R \iff x \in_{\mathbf{1}} R \iff \mathbf{1} \xrightarrow{x} R. \quad (370)$$

Under the interpretation in  $\mathcal{G}$  it becomes

$$x \in \text{Hom}(-, \ell C^\infty(\mathbb{R})) \iff x \in_{\mathbf{1}} \text{Hom}(-, \ell C^\infty(\mathbb{R})) \iff \mathbf{1} \xrightarrow{x} \text{Hom}(-, \ell C^\infty(\mathbb{R})) \iff \quad (371)$$

<sup>31</sup>The existence of such functor is easy to accept, because in the classical case *a differentiable manifold is uniquely determined by the algebraic structure of its commutative ring of differentiable functions* [Isham:1995].

$$\iff x \in \text{Hom}(\text{Hom}(-, \ell C^\infty(\mathbb{R}^0)), \text{Hom}(-, \ell C^\infty(\mathbb{R}))) \cong x \in \text{Hom}(\ell C^\infty(\mathbb{R}^0), \ell C^\infty(\mathbb{R})), \quad (372)$$

where the last isomorphism is obtained by the Yoneda lemma. So, *the interpretation of a concept of real* at stage  $\ell C^\infty(\mathbb{R}^n)/I$  is an equivalence class of *smooth functions*  $f(x) \bmod I$ , where  $f \in C^\infty(\mathbb{R}^n)$ . The real number is ‘smoothly varying’ over some space  $\mathbb{R}^n$ .

## Some historical remarks

Synthetic Differential Geometry can be traced back to the famous *Categorical Dynamics* lectures of William Lawvere given in Chicago in 1967 and published in [Kock:1979]. Some of important ideas and notions present in SDG were given in works of André Weil, Alexandre Grothendieck and Charles Ehresmann. The real development of SDG started in the second half of 1970s, with the works of Wraith (unpublished), Kock [Kock:1977], [Kock:1978] and others. Weil algebras were introduced by Weil in [Weil:1953]. The idea of a microlinear space was presented in the work of Bergeron [Bergeron:1980]. The generalized Kock-Lawvere axiom was given in [Kock:1981]. Vector fields and bundles were investigated in SDG in [Reyes:Wraith:1979], [Kock:1979] and [Kock:Reyes:1979]. Connections (as well as connection maps) were introduced in [Kock:Reyes:1979]. An important later development of this field is in [Moerdijk:Reyes:1991], and we follow here mainly the presentation given in this book, although their treatment is very condensed, and we have tried to give more graphical explanations. The iterated tangent bundles were investigated in [Bunge:Sawyer:1984]. The strong difference with applications to connections are discussed in [Kock:Lavendhomme:1984]. Differential forms are developed in [Kock:1979] and [Kock:etal:1980]. Further developments in this area were [Belair:1981], [Kock:1981], [Minguez:1985], [Minguez:1988a] and [Minguez:1988b]. Curvature and torsion were introduced in [Kock:Reyes:1979]. Further developments are [Kock:Lavendhomme:1984], [Lavendhomme:1987] and [Lavendhomme:1996]. Nishimura in a series of papers [Nishimura:1997], [Nishimura:2000] and [Nishimura:2001] has established the first and second Bianchi identities in the synthetic context using the calculus of strong differences on microcubes. Axiomatic structure of SDG is discussed in [Kock:1981], [Moerdijk:Reyes:1991] and [Grinkevich:1996a], [Grinkevich:1996b]. The subject of intuitionistic fields and rings are concerned in [Mulvey:1974] and [Mulvey:1979]. The notion of apartness appears for the first time and is developed in the works of Heyting [Heyting:1940], [Heyting:1970]. However, Heyting has defined the apartness on the field of fractions, while in SDG we consider  $R$  which is the field of quotients. The corresponding formulation for the case of the field of quotients was given by Grinkevich in [Grinkevich:1996a]. Some elements of presentation of the basis in SDG are taken from Fearnas [Fearnas:2002] and Grinkevich [Grinkevich:1996a], [Grinkevich:1996b]. Formal étale maps nad formal manifolds were concerned in the context of SDG in [Kock:Reyes:1979]. Further development of this area is in [Kock:1981]. Grinkevich in [Grinkevich:1996a] gives some new interesting details. The ‘coordinatization’ of curvature tensor was given in [Kock:Reyes:1979] and is recalled in [Moerdijk:Reyes:1991]. The properties of the metric were analysed in [Grinkevich:1996a] and are reviewed shortly in [Grinkevich:1996b]. The theory of well-adapted models of SDG (presented briefly in the section 3.2) was created by Eduardo Dubuc [Dubuc:1979], [Dubuc:1980], [Dubuc:1981a], [Dubuc:1981b], [Dubuc:1986] and was developed later by Moerdijk and Reyes and established in their monography [Moerdijk:Reyes:1991]. Dubuc was also an inventor of the topos  $\mathcal{G}$  and the one who began the systematic studies of  $C^\infty$ -rings, followed also by the works of Moerdijk and Reyes (and van Quê). The comprehensive treatment of this are as well as a standard reference is the monography [Moerdijk:Reyes:1991]. So far, the only books about SDG were: the foundational monography of Anders Kock [Kock:1981], rather condensed but also readable monography about well-adapted models of Ieke Moerdijk and Gonzalo Reyes [Moerdijk:Reyes:1991], the pedagogically naive-style presentation (i.e. without introducing the categories and toposes) by René Lavendhomme [Lavendhomme:1996] (its earlier version was published in French as [Lavendhomme:1987]) and the elementary textbook of John Bell [Bell:1998]. The book of Moerdijk and Reyes, although it is about the smooth *models* of infinitesimal calculus, gives also a very good treatment of connections in SDG, more general than the one given in [Lavendhomme:1996]. These two boks are together with [Kock:1981] the standard references in the field. In our presentation of SDG we made use of some parts of

---

material presented in these books. Because of the lack of spacetime, we have omitted some additional material, as integration, theory of principal fibre bundles, variational calculus or topology (axiomatic and in models). We would like to note that this text does not cover also a different version of a synthetic approach to differential geometric notions (such like curvature, connection and parallel transport) developed by Kock in the series of papers [Kock:1980], [Kock:1982], [Kock:1983], [Kock:1985], [Kock:1996], [Kock:1998], whose idea is to deal directly with pure geometrical notion of the points on a manifold, as well as their first and second neighbourhood on the diagonal.

## References

- [1] Artin, M., Grothendieck, A. and Verdier, J.-L., *Théorie des Topos* (SGA 4), Springer LNM 269, 270 (1972).
- [2] Baez, J., *Topos theory for physicists*, <http://www.lns.cornell.edu/spr/2001-01/msg0030351.html>. (2001)
- [3] Baez, J., *Quantum Quandries: A Category-Theoretic Perspective*, quant-ph/0404040. (2004)
- [4] Barr, M., Wells, C., *Toposes, Triples and Theories*, Springer-Verlag, Berlin 1983. Available at <http://www.cwru.edu/artsci/math/wells/pub/ttt.html>.
- [5] Bell, J.L., *From Absolute to Local Mathematics*, Synthese, 69 (1986) 3, pp. 409-426.
- [6] Bell, J.L., *Toposes and Local Set Theories: An Introduction*, Oxford University Press, Oxford 1988.
- [7] Bell, J.L., *A Primer of Infinitesimal Analysis*, Cambridge University Press, Cambridge 1998.
- [8] Bergeron, F., *Objet infinitésimalement linéaire dans un modèle adapté de GDS*, in: Géométrie Différentielle Synthétique, ed. G. Reyes, Rapport de Recherches, DMS 80-12, Univ. de Montréal, 1980.
- [9] Bertram, W., *Differential Geometry, Lie Groups and Symmetric Spaces over General Base Fields and Rings*, math.DG/0502168. (2005)
- [10] Blass, A., *The interaction between category theory and set theory*, in: Mathematical Applications of Category Theory, Contemporary Mathematics vol. 30, AMS Providence, 1983.
- [11] Boole, G., *The Calculus of Logic*, Cambridge and Dublin Mathematical Journal, Vol. 3 (1848), pp. 183-198.
- [12] Boileau, A., Joyal, A., *La logique des topos*, Journal of Symbolic Logic, 46 (1981) pp. 6-16.
- [13] Boyer, C.B., *The History of the Calculus and its Conceptual Development*, Dover 1959.
- [14] Bunge, M., *Toposes in Logic and Logic in Toposes*, Topoi, 3, no.1, pp. 13-22. (1984)
- [15] Bunge, M., Heggie, M., *Synthetic calculus of variations*, in: Mathematical Applications of Category Theory, Contemporary Mathematics, No. 30, AMS Providence 1984.
- [16] Bunge, M., Sawyer, P., *On connections, geodesics and sprays in synthetic differential geometry*, Cahiers de Topologie et Géométrie Différentielle Catégoriques 25 (1984) pp. 221-258.
- [17] Bunge, M., Dubuc, E., *Local concepts and germ representability*, in: D.W. Kueker, E.G.K. Lopez-Escobar and C.H. Smith (eds.), Mathematical Logic and Theoretical Computer Science, Marcel Dekker, New York 1987, pp. 93-160.
- [18] Cartan, E., *Leçons sur la géométrie des espaces de Riemann*, Gauthier-Villars, Paris 1928.
- [19] Cartan, E., *Sur les variétés à connexion affine et la théorie de la relativité généralisée*, Gauthier Villars, 1955. (English translation: *On manifolds with an affine connection and the theory general relativity*, transl. A. Magnon and A. Ashtekar, with foreword by A. Trautman, Bibliopolis, Napoli 1986.)
- [20] Davis, M., *Applied Nonstandard Analysis*, Wiley, New York 1977.
- [21] Demazure, M., Gabriel, P., *Groupes algébriques (Tome I)*. North-Holland, Amsterdam 1970.
- [22] Dieudonné, J., *History of functional analysis*, North-Holland, Amsterdam 1981.
- [23] Dombrowski, P., *On the geometry of the tangent bundle*, J. Reine Angew. Math. 210 (1962), pp. 73-88.
- [24] Dubuc, E., *Sur les modèles de la géométrie différentielle synthétique*, Cahiers de Topologie et Géométrie Différentielle Catégoriques 20 (1979), pp. 231-279.
- [25] Dubuc, E., *Schemas  $C^\infty$* , Prepublications de la Université de Montreal 80-81, ed. G.E. Reyes (1980).
- [26] Dubuc, E.,  *$C^\infty$  Schemes*, American Journal of Mathematics, John Hopkins University, Vol. 103-4 (1981).
- [27] Dubuc, E., *Open Covers and Infinitary Operations in  $C^\infty$ -rings*, Cahiers de Topologie et Géométrie Différentielle Catégoriques 22 (1981).
- [28] Dubuc, E., *Germ representability and Local integration of vector fields in a well adapted model of SDG*, Journal of Pure and Applied Algebra 64 (1990).
- [29] Ehresmann, C., *Les connexions infinitésimales dans un espace fibré différentiable*, in: Colloque de Topologie (Espaces Fibrés), Bruxelles 1950, Masson et Cie, Paris 1951, pp. 29-55.
- [30] Eilenberg, S., Mac Lane, S., *Group Extensions and Homology*, Annals of Mathematics, 43 (1942) pp. 757-831.
- [31] Eilenberg, S., Mac Lane, S., *General Theory of Natural Equivalences*, Transactions of the American Mathematical Society, 58 (1945) pp. 231-294.

- [32] Fearn, J.D., *A Physical Quantum model in a Smooth Topos*, quant-ph/0202079. (2002)
- [33] Feferman, S., *Categorical Foundations and Foundations of Category Theory*, Logic, Foundations of Mathematics and Computability, ed. R. Butts and J. Hintikka, Reidel, Dordrecht 1977, pp. 149-169.
- [34] Fourman, M.P., Mulvey, C.J., Scott, D.S., *Applications of Sheaf Theory to Algebra, Analysis and Topology*, (eds.), Lecture Notes in Mathematics 753, Springer 1979.
- [35] Fulton, W., MacPherson, R., *Categorical Framework for the Study of Singular Spaces*, Memoirs AMS 243, Providence, Rhode Island, 1981.
- [36] Gel'fand, I.M., *Matematičeskij Sbornik*, t.9 (1941) pp. 3-24. (in Russian)
- [37] Goldblatt, R., *Topoi. The categorical analysis of logic*, Studies in Logic and the Foundations of Mathematics vol. 98, North-Holland, Oxford 1979.
- [38] Godbillon, C., *Géométrie Différentielle et Mécanique Analytique*, Hermann, Paris 1969.
- [39] Grinkevich, E.B., *Metric in Synthetic Differential Geometry*, Master Thesis, Omsk 1996. (in Russian). Available at [http://www.univer.omsk.su/~topoi/Literature/grin\\_dip.zip](http://www.univer.omsk.su/~topoi/Literature/grin_dip.zip)
- [40] Grinkevich, E.B., *Synthetic Differential Geometry: A Way to Intuitionistic Models of General Relativity in Toposes*, gr-qc/9608013. (1996)
- [41] Grothendieck, A., *Sur quelques points d'algèbre homologique*, Tohoku Math. J. 9 (1957) pp. 119-221.
- [42] Guts, A.K., *A topos-theoretic approach to the foundations of Relativity Theory*, Soviet Math. Dokl. 43 (1991), No. 3, pp. 904-907.
- [43] Guts, A.K., *Topos-theoretic model of the Deutsch multiverse*, Mathematical structures and modelling, No. 8, (2001), pp. 76-90. (in Russian)
- [44] Guts, A.K., *Topos-theoretic model of the Deutsch multiverse*, physics/0203071. (2002)
- [45] Guts, A.K., *The theory of Multiverse, multiplicity of physical objects and physical constants*, gr-qc/0210072. (2002)
- [46] Guts, A.K., *The Elements of Time Theory*, Nasledye Publ., Dialog-Syberia 2004.
- [47] Guts, A.K., Grinkevich, E.B., *Toposes in General Theory of Relativity*, gr-qc/9610073. (1996)
- [48] Guts, A.K., Zvyagintsev, A.A., *Solution of the vacuum Einstein equations in Synthetic Differential Geometry of Kock-Lawvere*, physics/990916. (1999)
- [49] Guts, A.K., Zvyagintsev, A.A., *Interpretation of intuitionistic solution of the vacuum Einstein equations in smooth topos*, gr-qc/0001076. (2000)
- [50] Hawkings, E., Markopoulou, F., Sahlmann, H., *Evolution in quantum casual histories*, Class. Quant. Grav. 20 (2003), pp. 3839-2854. Also available at hep-th/0302111.
- [51] Hellman, G., *Does category theory provide a framework for mathematical structuralism?*, Philosophia Mathematica (3) 2003, 11, pp. 129-157.
- [52] Hermida, C., Makkai, M., Power, J., *On weak higher-dimensional categories I*, Journal of Pure and Applied Algebra 154 (2000) pp. 221-246.
- [53] Hermida, C., Makkai, M., Power, J., *On weak higher-dimensional categories II*, Journal of Pure and Applied Algebra 157 (2001) pp. 247-277.
- [54] Hermida, C., Makkai, M., Power, J., *On weak higher-dimensional categories III*, Journal of Pure and Applied Algebra 166 (2002) pp. 83-104.
- [55] Heyting, A., *Die formalen Regeln der intuitionistischen Logik*, Sitzungsber. preuss. Akad. Wiss., Berlin 1930, pp. 42-56.
- [56] Heyting, A., *Die formalen Regeln der intuitionistischen Mathematik*, Sitzungsber. preuss. Akad. Wiss., Berlin 1930, pp. 57-71, 158-169.
- [57] Heyting, A., *Untersuchungen über intuitionistische Algebra*, Verhandelingen Akad. Amsterdam, 1. sectie 18 N° 2. (1941)
- [58] Heyting, A., *Intuitionism – An Introduction*, Studies in Logic and Foundations of Mathematics, North-Holland, Amsterdam 1956. Third revised edition 1971.
- [59] Isham, C.J., *Modern Differential Geometry For Physicists*, World Scientific Lecture Notes in Physics Vol. 32, World Scientific, Singapore 1991.
- [60] Isham, C.J., *Structural Issues in Quantum Gravity*, gr-qc/9510063. (1995)
- [61] Isham, C.J., *Topos Theory and Consistent Histories: The Internal Logic of the Set of all Consistent Sets*, gr-qc/9607069. (1996)
- [62] Isham, C.J., *Some reflections on the status of conventional quantum theory when applied to quantum gravity*, quant-ph/0206090. (2002)
- [63] Isham, C.J., *A New Approach to Quantising Space-Time: I. Quantising on a General Category*, gr-qc/0303060. (2003)
- [64] Isham, C.J., *A New Approach to Quantising Systems: II. Quantising on a Category of Sets*, gr-

- qc/0304077. (2003)
- [65] Isham, C.J., *Quantising on a Category*, quant-ph/0401175. (2004)
- [66] Isham, C.J., Butterfield, J., *Some Possible roles for Topos Theory in Quantum Theory and Quantum Gravity*, gr-qc/9910005. (1999)
- [67] Johnstone, P.T., *Topos Theory*, LMS Monograph 10, Academic Press Inc, London 1977.
- [68] Johnstone, P.T., *Sketches of an Elephant: a Topos Theory Compendium*, Vol. 1, Oxford Logic Guides 43, Oxford University Press, Oxford 2002.
- [69] Johnstone, P.T., *Sketches of an Elephant: a Topos Theory Compendium*, Vol. 2, Oxford Logic Guides 44, Oxford University Press, Oxford 2002.
- [70] Kan, D.M., *Adjoint functors*, Transactions of the AMS, 87, pp. 294-329.
- [71] Kasch, F., *Moduln und Ringe*, Teubner, Stuttgart 1977.
- [72] Kennison, J.F., *Solution manifolds for systems of differential equations*, Theory and Applications of Categories, Vol. 7, No. 13, 2000, pp. 239-262.
- [73] Kobayashi, S., Nomizu, K., *Foundations of Differential Geometry*, Vol. I, Wiley Interscience, New York 1963.
- [74] Kobayashi, S., Nomizu, K., *Foundations of Differential Geometry*, Vol. II, Wiley Interscience, New York 1969.
- [75] Kock, A., *A simple axiomatics for differentiation*, Mathematica Scandinavica 40 (1977) pp. 183-193.
- [76] Kock, A., *Taylor series for calculus for ring objects of line type*, Journal of Pure and Applied Algebra 12 (1978) pp. 271-293.
- [77] Kock, A., *Differential Forms in Synthetic Differential Geometry*, Aarhus Preprint Series No. 28. (1978)
- [78] Kock, A., *Formal real rings and infinitesimal stability*, in: Topos Theoretical Methods in Geometry, Aarhus Math. Inst. Var. Publ. Series No. 30 (1979).
- [79] Kock, A., *On the synthetic theory of vector fields*, in: Topos Theoretical Methods in Geometry, Aarhus Math. Inst. Var. Publ. Series No. 30 (1979).
- [80] Kock, A., (ed.), *Topos Theoretical Methods in Geometry*, Aarhus Math. Inst. Var. Publ. Series No. 30 (1979).
- [81] Kock, A., *Synthetic Differential Geometry*, London Mathematical Society Lecture Note Series, vol. 51, Cambridge University Press, Cambridge 1981.
- [82] Kock, A., *Properties of well-adapted models for synthetic differential geometry*, Journal of Pure and Applied Algebra 20 (1981) pp. 55-70.
- [83] Kock, A., *Remarks on connections and sprays*, in: Category Theoretic Methods in Geometry, Aarhus Var. Publ. Series 35 (1983).
- [84] Kock, A., *A combinatorial theory of connections*, in: Mathematical Applications of Category Theory, AMS Contemporary Mathematics 30 (1983) pp. 132-144.
- [85] Kock, A., (ed.), *Category Theoretic Methods in Geometry*, Aarhus Var. Publ. Series 35 (1983).
- [86] Kock, A., *Combinatorics of curvature, and the Bianchi identity*, Theory and Applications of Categories, 2 (1996) pp. 69-89.
- [87] Kock, A., *Geometric Construction of the Levi-Civita parallelism*, Theory and Application of Categories, Vol. 4, No. 9, 1998, pp. 195-207.
- [88] Kock, A., Lavendhomme, R., *Strong infinitesimal linearity, with applications to strong difference and affine connections*, Cahiers de Topologie et Géométrie Différentielle Catégoriques 25 (1984) pp. 311-324.
- [89] Kock, A., Reyes, G.E., *Manifolds in formal differential geometry*, in: Applications of Sheaves, Lecture Notes in Mathematics 735, Springer 1979.
- [90] Kock, A., Reyes, G.E., *Connections in formal differential geometry*, in: Topos Theoretic Methods in Geometry, Aarhus Var. Publ. Series 30 (1979).
- [91] Kock, A., Reyes, G.E., *Models for synthetic integration theory*, Mathematica Scandinavica 48 (1981) pp. 145-152.
- [92] Kock, A., Reyes, G.E., *Some differential equations in SDG*, math.CT/0104164. (2001)
- [93] Kock, A., Reyes, G.E., *Ordinary differential equations and their exponentials*, University of Aarhus, Preprint Series No. 12, 2004.
- [94] Kock, A., Reyes, G.E., Veit, B., *Forms and integration in Synthetic Differential Geometry*, Aarhus Preprint Series 31 (1980).
- [95] Kolař, I., *Fundamental vector fields on associated fibre bundles*, Časopis pro pest. mat. 102 (1977), pp. 419-425.



- [96] Kolař, I., *On the second tangent bundle and generalized Lie derivatives*, Tensor N.S. 38 (1982) pp. 98-102.
- [97] Kolař, I., Michor, P.W., Slovák, J., *Natural operations in differential geometry*, Springer, Berlin 1993.
- [98] Komrakov, B.P., *Structures on manifolds and affine spaces*, Nauka i Technika, Minsk 1978. (in Russian)
- [99] Kriegel, A., Michor, P., *The Convenient Setting of Global Analysis*, AMS 1997.
- [100] Kripke, S.A., *Semantic analysis of intuitionistic logic I*, in: Formal Systems and Recursive Functions, ed. J.N. Crossley and M.A. Dummett, North-Holland, Amsterdam 1965, pp. 92-130.
- [101] Lambek, J., Scott, P.J., *Aspects of Higher Order Categorical Logic*, in: Mathematical Applications of Category Theory, Contemporary Mathematics vol. 30, AMS Providence, 1983.
- [102] Lambek, J., Scott, P.J., *Introduction to Higher Order Categorical Logic*, Cambridge University Press, Cambridge 1986.
- [103] Landry, E., Marquis, J.-P., *Categories in Context: Historical, Foundational, and Philosophical*, Philosophia Mathematica 3 (2005) 13, pp. 1-43.
- [104] Lang, S., *Algebra*, Addison-Wesley, New York 1965.
- [105] Lavendhomme, R., *Notes sur l'algèbre de Lie d'un groupe de Lie en géométrie différentielle synthétique*, Rapport 111, Inst. de Math., Louvain-La-Neuve 1981.
- [106] Lavendhomme, R., *Leçons de Géométrie Différentielle Synthétique Naïve*, Monographies de Math. 3, Inst. Math. Louvain-La-Neuve 1987.
- [107] Lavendhomme, R., *Basic Concepts of Synthetic Differential Geometry*, Kluwer Academic Publishers, Dordrecht 1996.
- [108] Lavendhomme, R., Nishimura, H., *Differential Forms in Synthetic Differential Geometry*, Int. Journ. of Theor. Phys., Vol. 37, No. 11, 1998, pp. 2823-2832.
- [109] Lawvere, F.W., *Functorial Semantics of Algebraic Theories*, Proceedings of the National Academy of Sciences U.S.A., 50 (1963) pp. 869-872. (Ph.D. Thesis, Columbia University, New York 1963.)
- [110] Lawvere, F.W., *An Elementary Theory of the Category of Sets*, Proceedings of the National Academy of Sciences U.S.A., 52 (1964) pp. 1506-1511.
- [111] Lawvere, F.W., *The Category of Categories as a Foundation for Mathematics*, Proceedings of the La Jolla conference on Categorical Algebra, Springer-Verlag, New York 1966, pp. 1-21.
- [112] Lawvere, F.W., *Adjointness in Foundations*, Dialectica, 23 (1969) pp. 281-295.
- [113] Lawvere, F.W., *Quantifiers and Sheaves*, in: Actes du Congrès International des Mathématiciens, Nice 1970, pp. 329-334.
- [114] Lawvere, F.W., *Categorical Dynamics*, in: Topos Theoretic Methods in Geometry, ed. A. Kock, Aarhus Various Publ. Series 30 (1979). (Lectures given in Chicago in 1967.)
- [115] Lawvere, F.W., *Foundations and Applications: Axiomatization and Education. New Programs and Open Problems in the Foundation of Mathematics*, Bulletin of Symbolic Logic, 9, 2 (2003) pp. 213-224.
- [116] Lie, S., *Allgemeine Theorie der partiellen Differentialgleichungen erster Ordnung*, Math. Ann. 9 (1876) pp. 246-296.
- [117] Lie, S., *Vorlesungen über Differentialgleichungen*, ed. by G. Scheffers, Leipzig und Berlin 1912.
- [118] Leinster, T., *A Survey of Definitions of  $n$ -categories*, Theory and Applications of Categories, 10 (2002) pp. 1-70.
- [119] Lusin, N.N., *Collected Works*, t. 3, Moskva 1959. (in Russian)
- [120] Mac Lane, S., *Categories for the Working Mathematician*, Springer, New York 1971.
- [121] Mac Lane, S., Birkhoff, G., *Algebra*, Macmillan, New York 1967.
- [122] Mac Lane, S., Moerdijk, I., *Sheaves in Geometry and Logic. A First Introduction to Topos Theory*, Springer, New York 1992.
- [123] Makkai, M., *Towards a Categorical Foundation of Mathematics*, Lecture Notes in Logic 11, Springer, Berlin 1998, pp. 153-190.
- [124] Makkai, M., Reyes, G.E., *First order categorical logic*, Lecture Notes in Mathematics 611, Springer, Berlin 1977.
- [125] Malgrange, B., *Ideals of Differentiable Functions*, Oxford 1966.
- [126] McLarty, C., *Learning from Questions on Categorical Foundations*, Philosophia Mathematica 3 (2005) 13, pp. 44-60.
- [127] Medvedev, F.A., *Non-standard analysis and the history of classical analysis*, in: Regularities of developments of contemporary mathematics, Nauka, Moskva 1987. (in Russian)

- [128] Mikkelsen, C.J., *Lattice-theoretic and logic aspects of elementary topoi*, Aarhus Universitet Various Publ. Series 25, 1976.
- [129] Moerdijk, I., Reyes, G.E., *Smooth spaces vs continuous spaces in models of SDG*, J. Pure Appl. Alg. 32 (1984), pp. 143-176.
- [130] Moerdijk, I., Reyes, G.E., *Rings of smooth functions and their localizations, I*, International Journal of Algebra, 99 (1986), pp. 324-336.
- [131] Moerdijk, I., Reyes, G.E., *Models for Smooth Infinitesimal Analysis*, Springer, New York 1991.
- [132] Moerdijk, I., van Quê, N. and Reyes, G.E., *Rings of smooth functions and their localizations, II*, in: D.W. Kueker, E.G.K. Lopez-Escobar and C.H. Smith (eds.), *Mathematical Logic and Theoretical Computer Science*, Marcel Dekker, New York 1987, pp. 277-300.
- [133] Minguez, M.C., *Cálculo diferencial sintético y su interpretacion en modelos de prehaces*, Publ. Sem. Mat. Serie II, Sec. 2, No. 15, Univ. Zaragoza 1985.
- [134] Minguez, M.C., *Wedge product of forms in Synthetic Differential Geometry*, Cahiers de Topologie et Géométrie Différentielle Catégoriques, 29 (1988) 1, pp. 59-66.
- [135] Minguez, M.C., *Some combinatorial calculus on Lie Derivative*, Cahiers de Topologie et Géométrie Différentielle Catégoriques, 29 (1988) 3, pp. 241-247.
- [136] Mulvey, C., *Intuitionistic algebra and representation of rings*, Memoris AMS 148, Providence, 1974.
- [137] Mulvey, C., *Representations of rings and modules*, Lecture Notes in Mathematics 753, Springer, Berlin 1979, pp. 542-585.
- [138] Nishimura, H., *Synthetic Hamiltonian Mechanics*, Int. Journ. of Theor. Phys. 36 (1997) pp. 259-279.
- [139] Nishimura, H., *Theory of microcubes*, Int. Journ. of Theor. Phys. 36 (1997) pp. 1099-1131.
- [140] Nishimura, H., *Nonlinear connections in synthetic differential geometry*, Journal of Pure and Applied Algebra 131 (1998), pp. 49-77.
- [141] Nishimura, H., *Infinitesimal Calculus of Variations*, Int. Journ. of Theor. Phys., Vol. 38, No. 6, 1999. pp. 1771-1782.
- [142] Nishimura, H., *Another curvature in synthetic differential geometry*, Bull. Belg. Math. Soc. 7 (2000), pp. 161-171.
- [143] Nishimura, H., *The first Bianchi identity in synthetic differential geometry*, Journal of Pure and Applied Algebra 160 (2001) pp. 263-274.
- [144] Osius, G., *A note on Kripke-Joyal semantics for the internal language of topoi*, in: *Model Theory and Topoi*, ed. F.W. Lawvere, Lecture Notes in Mathematics 445, Springer 1975.
- [145] van Quê, N., Reyes, G.E., *Smooth functors and synthetic calculus*, in: *The L.E.J. Brouwer Cantenary Symposium*, North Holland 1982, pp. 377-395.
- [146] Paré, R., *Colimits in topoi*, Bull. amer. Math. Soc., 80 (1974) pp. 556-561.
- [147] Penon, J., *De l'infinitesimal au local*, Ph.D. Thesis, Paris 1985.
- [148] Patterson, L.N., *Connections and prolongations*, Can. J. Math. 27, 4 (1975) pp. 766-791.
- [149] Rasiowa, H., Sikorski, R., *The Mathematics of Metamathematics*, PWN, Warszawa 1963.
- [150] Reyes, G.E., *Synthetic reasoning and variable sets*, in: Lawvere, F.W., and Schanuel, W., (eds.), *Categories in continuum physics*, Springer Lecture Notes 1174, Berlin 1986, pp. 69-82.
- [151] Reyes, G.E., Wraith, G.C., *A note on tangent bundles in a category with a ring object*, Mathematica Scandinavica 42 (1978) pp. 53-63.
- [152] Robinson, A., *Non-standard analysis*, Proc. Roy. Acad. Sci. Amst., ser. A, 1961, 64, pp. 432-440.
- [153] Robinson, A., *Introduction to model theory and to the metamathematics of algebra*, North-Holland, Amsterdam 1963.
- [154] Robinson, A., *Non-standard analysis*, North-Holland, Amsterdam 1966.
- [155] Rousseau, C., *Complex structures in topoi*, in: *Topos Theoretical Methods in Geometry*, Aarhus Math. Inst. Var. Publ. Series No. 30 (1979).
- [156] Russell, B., Whitehead, A.N., *Principia Mathematica*, London 1910-1913.
- [157] Sorensen, M.H., Urzyczyn, P., *Lectures on the Curry-Howard Isomorphism*, Elsevier 2005.
- [158] Schwinger, J., *Quantum Electrodynamics*, Dover, New York 1958.
- [159] Schutz, B.F., *Geometrical methods of mathematical physics*, Cambridge University Press, Cambridge 1982.
- [160] Stachel J, lecture given in May 2005 at Relativity Seminar in Institute for Theoretical Physics, Warsaw. (unpublished)
- [161] Wald, R.M., *General Relativity*, The University of Chicago Press, Chicago 1984.
- [162] Weil, A., *Théorie des points proches sur les variétés différentiables*, in: *Conference Geom. Diff.*, Strasbourg 1953. (Reprinted in: *Oeuvres scientifiques, collected papers*, vol. 2, Springer 1979, pp.

- 103-109.)
- [163] White, J.E., *The method of iterated tangents, with applications in local Riemannian geometry*, Pitman, Boston 1982.
- [164] Yoneda, N., *On the homology theory of modules*, J. Fac. Sci. Tokyo, Sec. 1, 1954, 7, pp. 193-227.
- [165] Zawadowski, M., *Elements of Category Theory*, Lecture Notes (unpublished), Warszawa 2002. (in Polish). Available at [http://duch.mimuw.edu.pl/~zawado/TK\\_all.pdf](http://duch.mimuw.edu.pl/~zawado/TK_all.pdf).

## Index

- $C^\infty$ -algebras, 81
- $C^\infty$ -homomorphisms, 81
- $C^\infty$ -rings, 81
- $k$ -linear form, 52
- $n$ -dimensional model, 70
- $n$ -homogeneous, 51
- $n$ -microcube, 51
- $n$ -twist, 51
- 2-tangent, 34
  
- acceleration field, 78
- affine connection, 35, 38
- affine scheme, 27
- affine space, 46
- affine space structure, 46
- antisymmetrization map, 54
- apart, 65, 72
- apartness, 65
- apartness relation, 67
- attached at, 28
- augmentation, 25
- axiom of integration, 78
  
- base point, 28, 68
- Bianchi identities, 59
- boundary operator, 55
  
- canonical form, 57
- Cauchy reals, 63
- change of model, 71
- Christoffel symbols, 73
- classical, 52
- classical  $k$ -linear form, 52
- classical differential  $n$ -form, 53
- classical tensor product, 52
- closed interval, 62
- collection of vectors, 66
- commutator, 31
- components of connection, 73
- connection form, 58
- connection map, 43
- constructive, 74
- covariant derivative, 44
- covering family, 70
- curvature, 58
- curvature form, 58
- curvature scalar, 76
- curvature tensor, 58
- curve, 77
  
- decidable, 21
- Dedekind reals, 63
- delta function, 72
- derivative, 77
- differential, 23
- differential  $n$ - $\phi$ -form, 57
- differential  $n$ -form, 53
- differential  $n$ -form with values in vector bundle  
     $p$  relative to  $\phi$ , 57
- dimension, 67
- directional derivative, 23, 31
- dual basis, 72
- Dubuc topos, 18, 82
  
- Einstein tensor, 77
- Euclidean  $R$ -module, 23
- exterior covariant derivative, 57
- exterior covariant differential, 57
- exterior derivative, 55
- exterior differential, 55
- exterior product, 54
  
- fibre, 28
- field of fractions, 63
- field of quotients, 63
- finite, 66
- finite basis, 67
- finite cardinal, 66
- finite collection of vectors, 66
- finite linear combination of vectors, 66
- finitely presented  $R$ -algebra, 24
- first-order, 20
- formal, 25
- formal  $n$ -dimensional manifold, 70
- formal étale, 68
- formally real ring, 63
  
- generate, 67
- generic tangent vector, 27
- geodesic curve, 78
- geometric field, 63
- germ, 18, 82
- germ-determined ideal, 18, 82
  
- higher-order infinitesimals, 22
- horizontal vectors, 40
  
- ideal of augmentation, 25
- infinitesimal, 27

- infinitesimal  $n$ -chains, 51
- infinitesimal parallelogram, 34
- infinitesimals, 20, 25
- interior product, 56
- invertible elements, 60
- iterated tangent bundle, 46
  
- Levi-Civita connection, 76
- Lie algebra, 32
- Lie bracket, 32
- Lie derivative, 31, 56
- Lie group, 32
- Lie monoid, 32
- linearly independent, 67
- local card, 71
- local coordinate system, 71
  
- marked  $n$ -microcube, 51
- marking, 51
- metric tensor, 75
- metrical connection, 76
- microlinear space, 27
- microsquare, 34
- mutually free, 67
  
- $n$ -microcube, 50
- nilpotent infinitesimals, 22
- nondegenerate, 75
- nonnegative, 75
- norm, 75
  
- object of infinitesimals, 64
- object of zeros, 18, 82
- open interval, 62
  
- parallel transport, 36, 43
- parallelizable, 71
- partial derivative, 23
- perceives, 27
- property W, 32
  
- quasi-colimits, 27
  
- real at stage  $\ell A$ , 19, 83
- regular epic, 69
- Ricci tensor, 76
- Riemann-Christoffel tensor, 58
- Riemannian structure, 75
  
- section, 28
- sheafification functor, 18, 82
- small objects, 25
- spectrum, 24
  
- strong difference, 47
- strongly linearly dependent, 67
- sub-bundles, 40
- symmetric, 35, 75
  
- tangent, 28
- tangent bundle, 28
- tangent space, 28
- tangent vector, 28
- tensor bundles, 52
- tensor product, 52
- torsion, 50
- torsion form, 58
- torsion free, 50
- torsor structure, 46
- translation space structure, 46
- trivial bundle, 57
- twist map, 49
  
- vector bundle, 28
- vector curve, 77
- vector field, 31
- vector space, 28
- velocity field, 78
- vertical vectors, 40
  
- Weil algebra, 25
- Whitney sum, 40