

Quantum Error Correction

Adam Bednorz

2026-05-12/13

Errors during transmission or idling

Bit-flip, accidental X

$$|0\rangle \rightarrow |1\rangle, |1\rangle \rightarrow |0\rangle$$

Phase-flip, accidental Z

$$|0\rangle \rightarrow |0\rangle, |1\rangle \rightarrow -|1\rangle$$

Protection,

$$\alpha|0\rangle + \beta|1\rangle \rightarrow \alpha|000\rangle + \beta|111\rangle$$

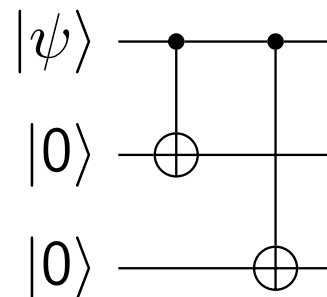

Correcting bit-flip

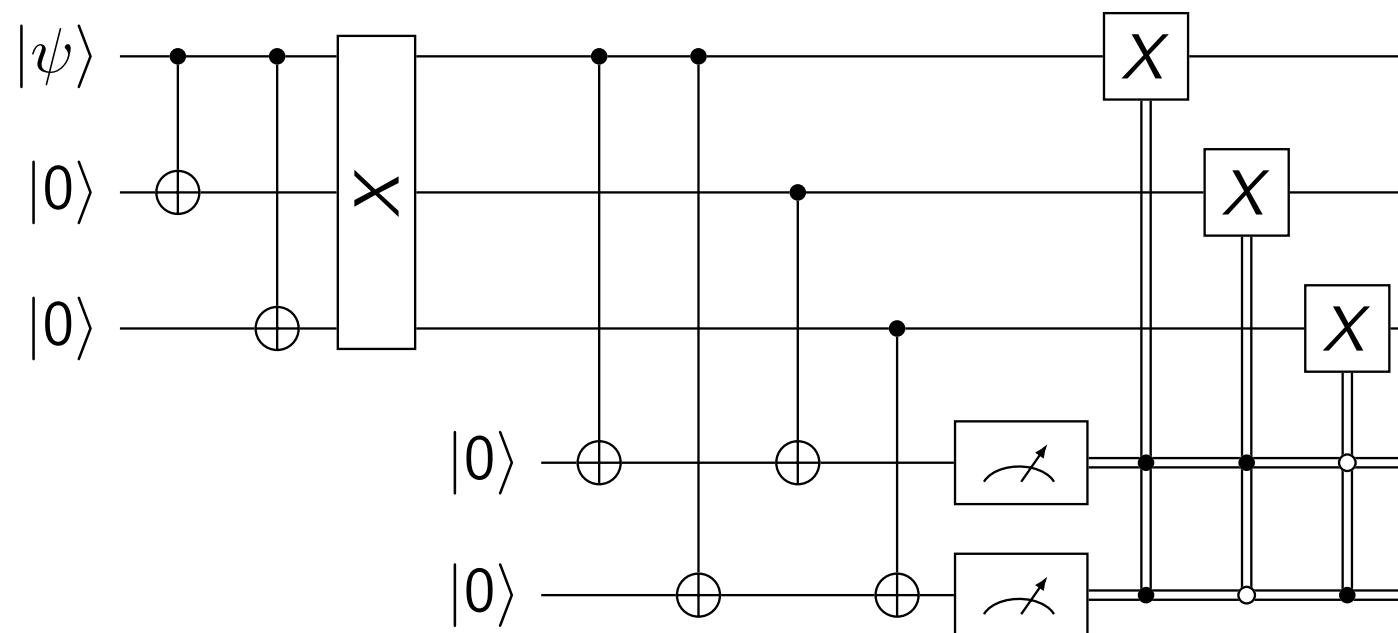

Single X flip

$$0 : (\alpha|000\rangle + \beta|111\rangle)|00\rangle, \quad 1 : (\alpha|100\rangle + \beta|011\rangle)|11\rangle,$$

$$2 : (\alpha|010\rangle + \beta|101\rangle)|10\rangle, \quad 3 : (\alpha|001\rangle + \beta|110\rangle)|01\rangle,$$

Results \rightarrow correction: $00 \rightarrow$ none, $11 \rightarrow X_1$, $10 \rightarrow X_2$, $01 \rightarrow X_3$.

Correcting phase-flip

$$Z = HXH$$

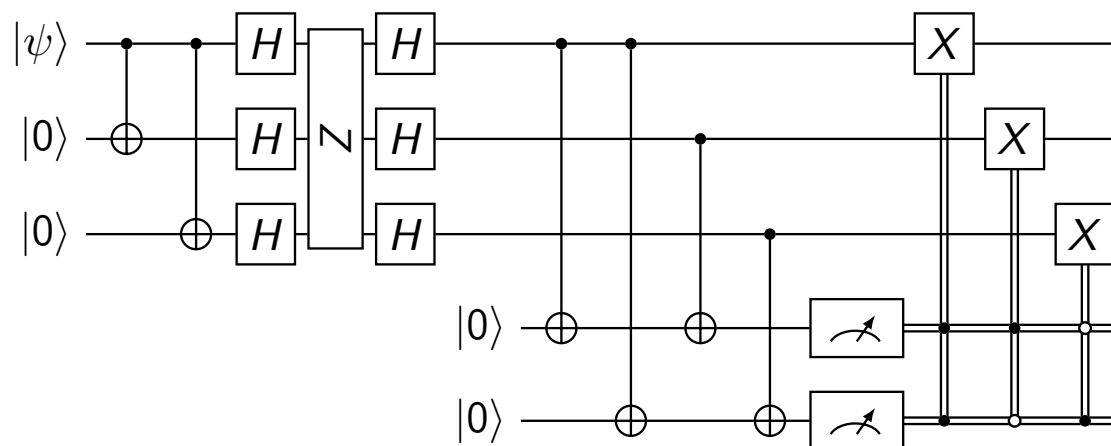

Single Z flip

$$0 : (\alpha|000\rangle + \beta|111\rangle)|00\rangle, \quad 1 : (\alpha|100\rangle + \beta|011\rangle)|11\rangle,$$

$$2 : (\alpha|010\rangle + \beta|101\rangle)|10\rangle, \quad 3 : (\alpha|001\rangle + \beta|110\rangle)|01\rangle,$$

Results \rightarrow correction: $00 \rightarrow$ none, $11 \rightarrow X_1$, $10 \rightarrow X_2$, $01 \rightarrow X_3$.

9-qubit Shor code (1995)

Errors: single bit-flip and single phase-flip

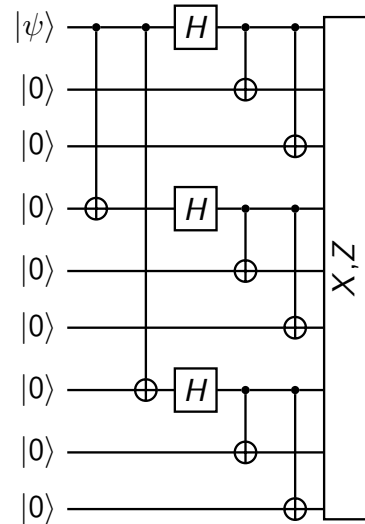

State $\alpha|0\rangle + \beta|1\rangle \rightarrow$

$$\frac{1}{\sqrt{8}}(\alpha(|000\rangle + |111\rangle)(|000\rangle + |111\rangle)(|000\rangle + |111\rangle) + \beta(|000\rangle - |111\rangle)(|000\rangle - |111\rangle)(|000\rangle - |111\rangle))$$

Full correction

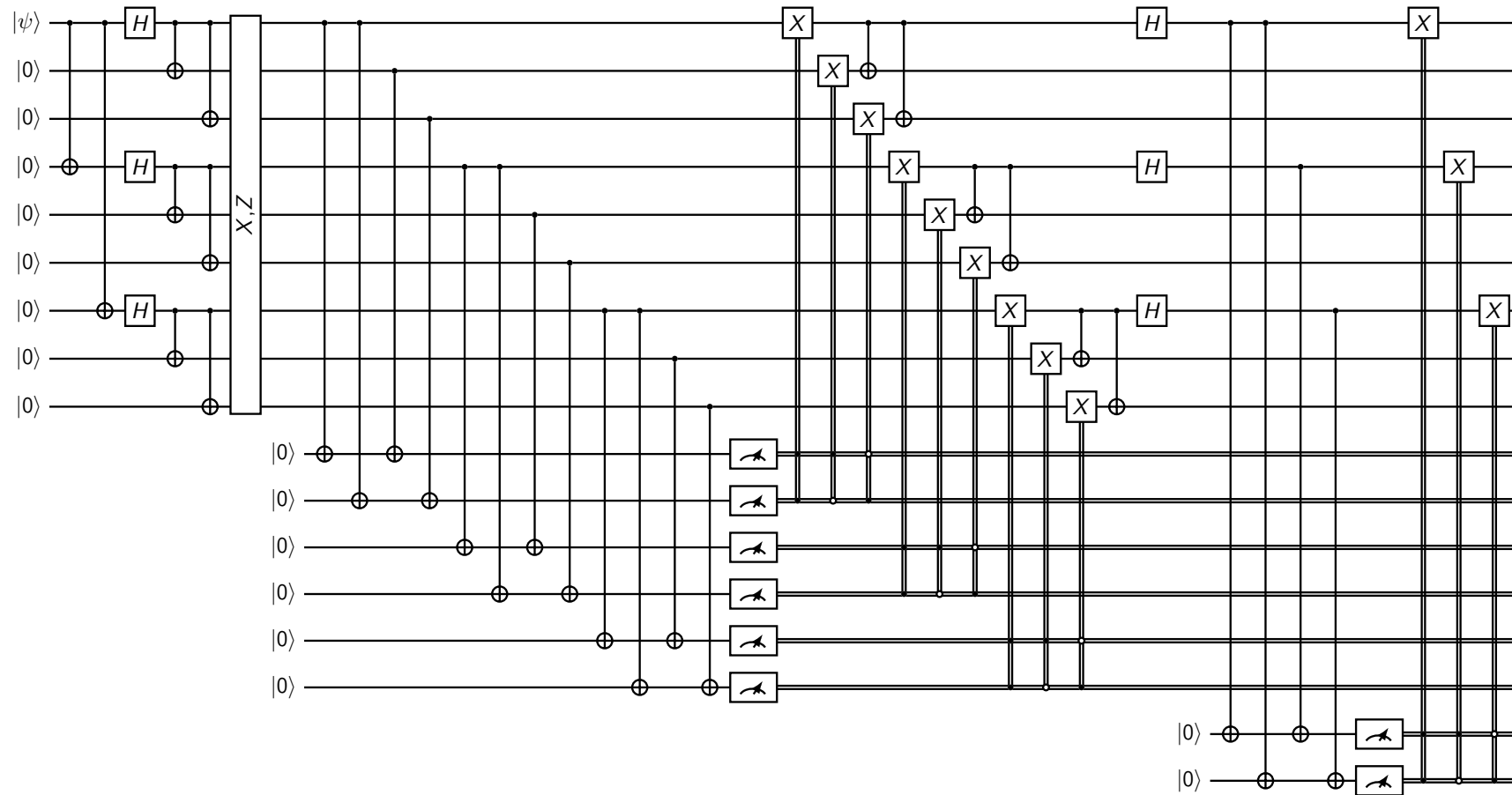

Stabilizers

Error E , $E^2 = I$, and stabilizer K , $K^2 = I$, $K = K^\dagger$ (e.g. X , Z)

Eigenspaces $K|\psi_\pm\rangle = \pm|\psi_\pm\rangle$, eigenvalues $K = \pm 1$.

$$EK = -KE$$

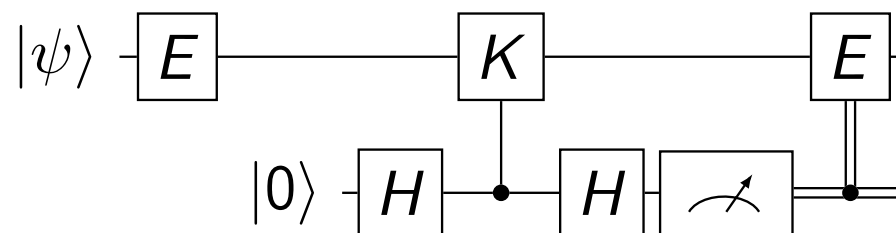

When the ancilla detects the change of eigenspace by K , it corrects by reversing the error.

Error correcting codes

Commuting family of stabilizers $K_1 = ZZI$, $K_2 = ZIZ$, $K_3 = XXX$.
Other examples: Kitaev $[[5, 1, 3]]$ and Shor $[[9, 1, 3]]$

					Z	Z	I	I	I	I	I	I	I
					Z	I	Z	I	I	I	I	I	I
X	Z	Z	X	I	I	I	I	Z	Z	I	I	I	I
I	X	Z	Z	X	I	I	I	Z	I	Z	I	I	I
X	I	X	Z	Z	I	I	I	I	I	I	Z	Z	I
Z	X	I	X	Z	I	I	I	I	I	I	Z	I	Z
					X	X	X	X	X	X	I	I	I
					X	X	X	I	I	I	X	X	X