

Shortest path optimizations

From graphs to ants

Problem

- I'm visiting Rome for only a few days, and I want to make the most of it. How I can plan my sightseeing in a way that minimizes the walking between attractions?



Problem

ROMA



Problem

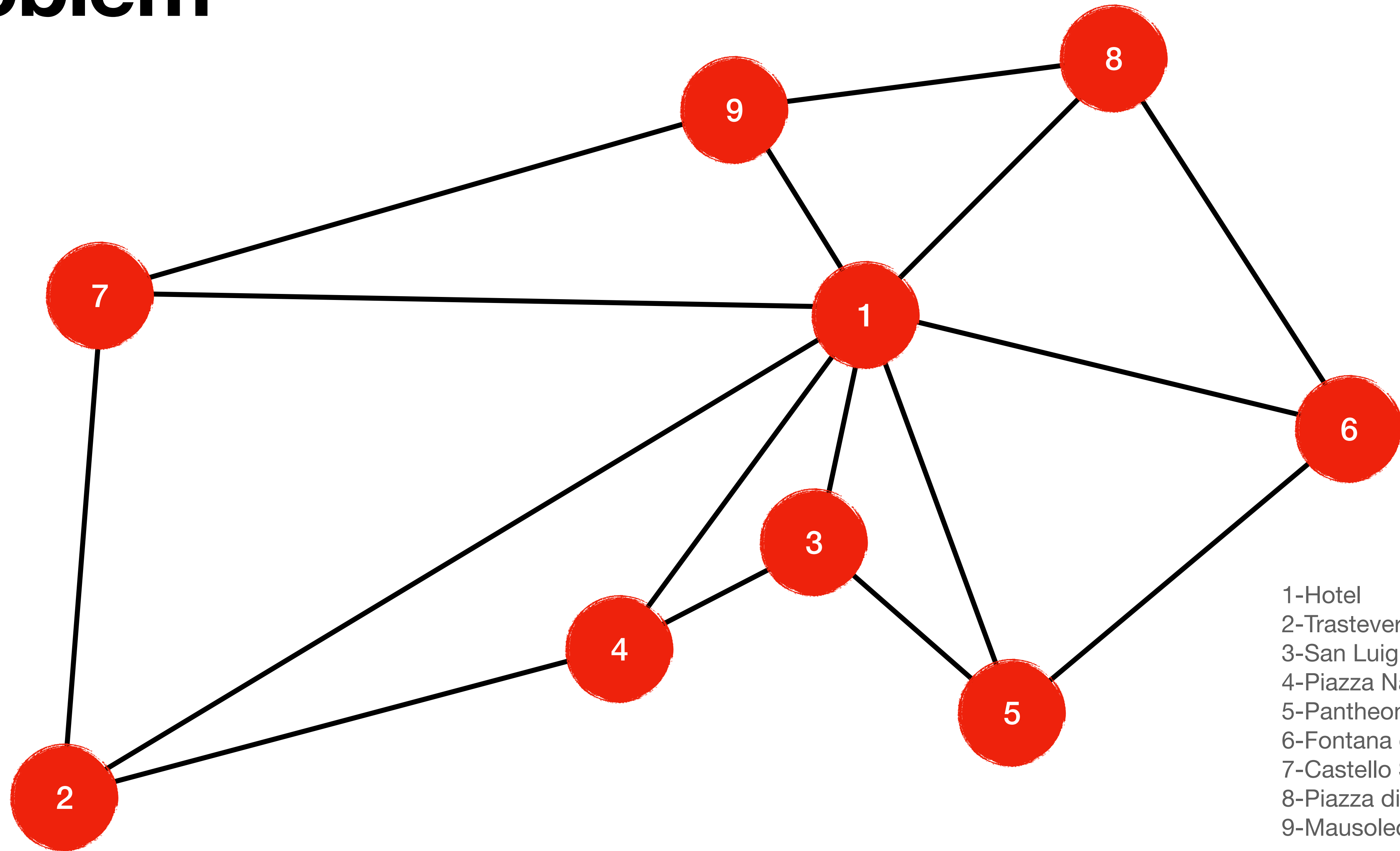

- 1-Hotel
- 2-Trastevere
- 3-San Luigi
- 4-Piazza Navona
- 5-Pantheon
- 6-Fontana de Trevi
- 7-Castello San Angelo
- 8-Piazza di Spagna
- 9-Mausoleo di Augusto

Problem

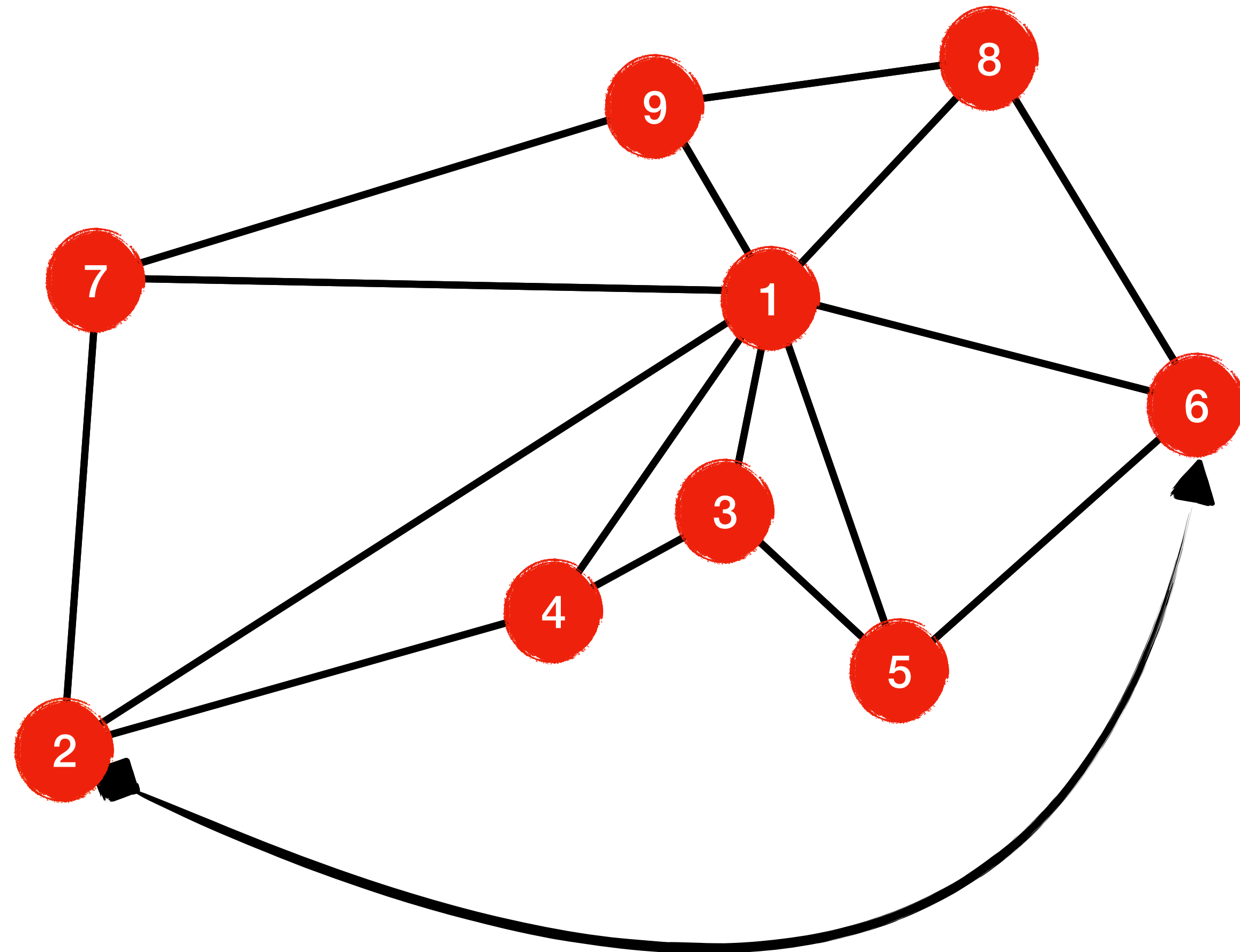

1-Hotel

2-Trastevere

3-San Luigi

4-Piazza Navona

5-Pantheon

6-Fontana de Trevi

7-Castello San Angelo

8-Piazza di Spagna

9-Mausoleo di Augusto

Why this problem matters to you?

ELECTRIC POWER DISTRIBUTION

Enter your sub headline here

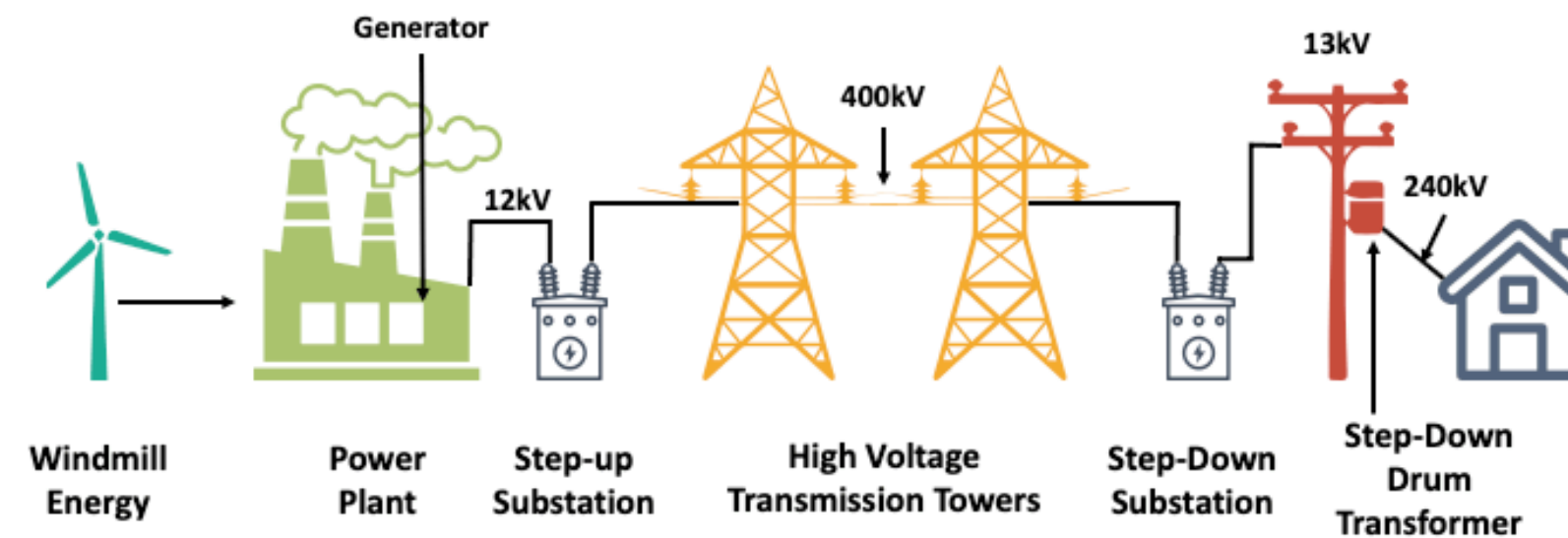

Warner L and Vogel U 2008 Optimization of energy supply networks using ant colony optimization Proc. Environmental Informatics and Industrial Ecology

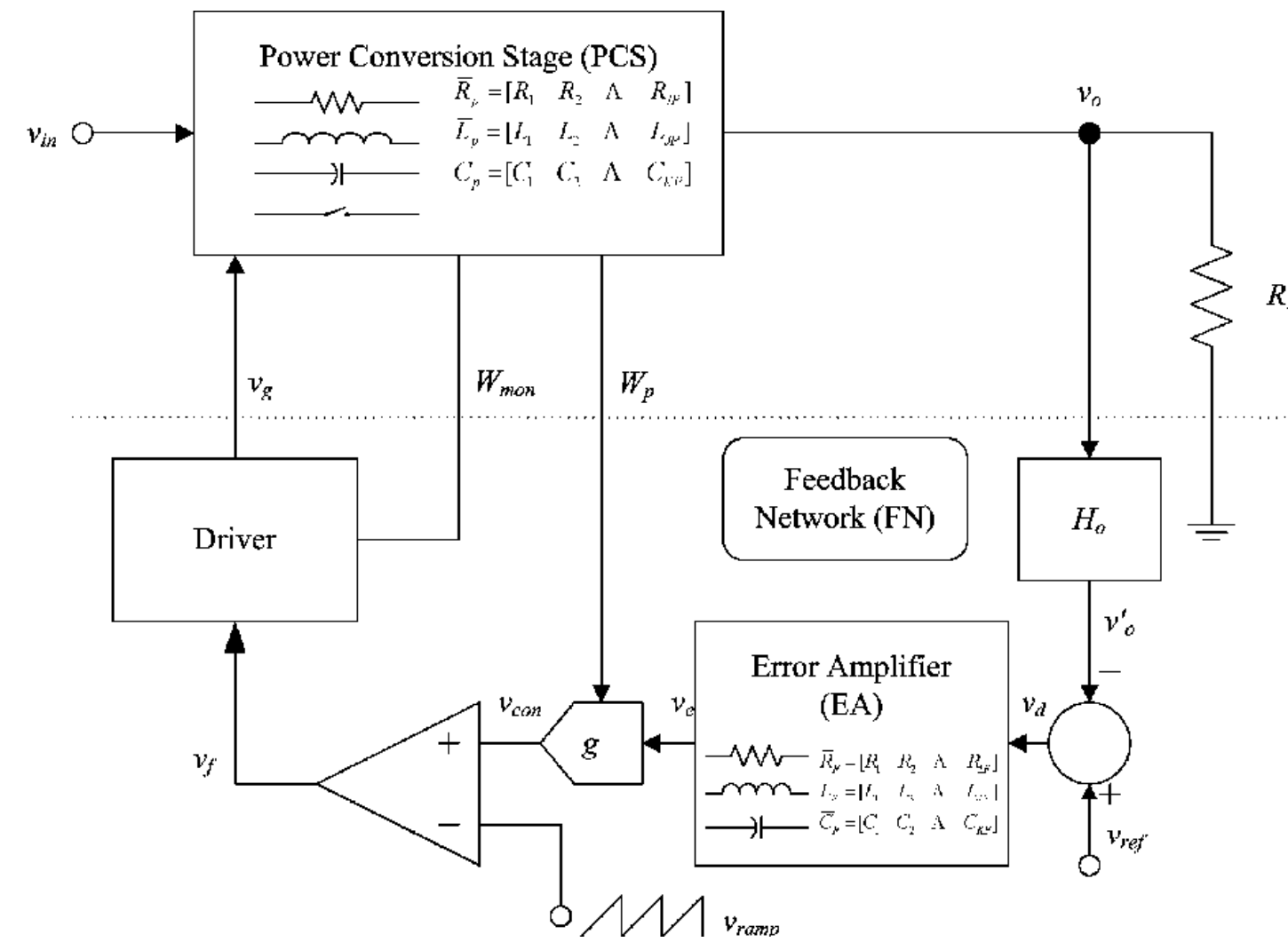

Zhang J, Chung H S-H, Lo A W-L and Huang T
2009 Extended Ant Colony Optimization
Algorithm for Power Electronic Circuit Design
IEEE Trans. Power Electron. 24 147-62

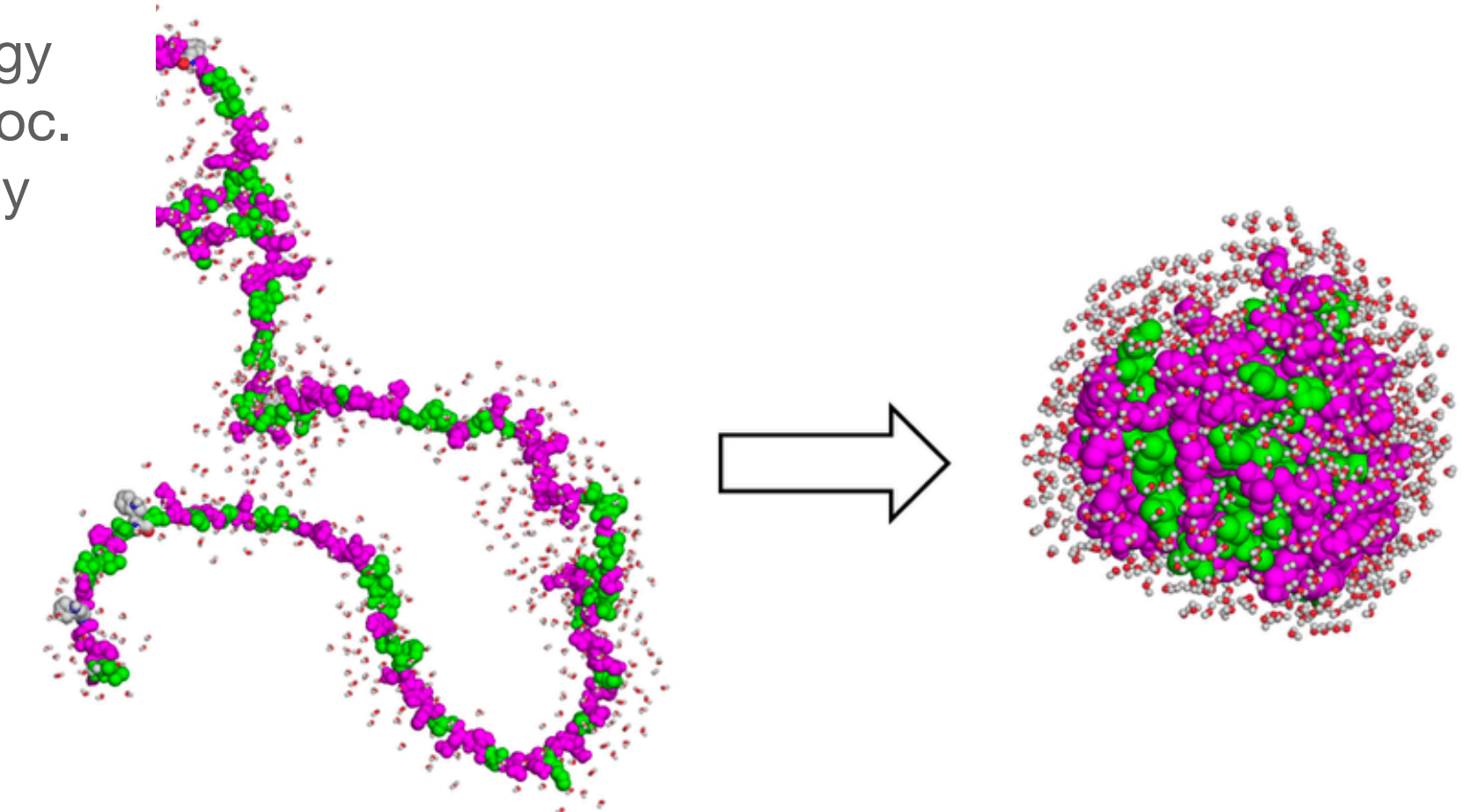

Unfolded

Folded

Hu X, Zhang J, Xiao J and Li Y 2008 Protein folding in hydrophobic-polar lattice model: a flexible ant-colony optimization approach
Protein Pept. Lett. 15 469-77

Why this problem matters to you?

ELECTRIC POWER DISTRIBUTION
Enter your sub headline here

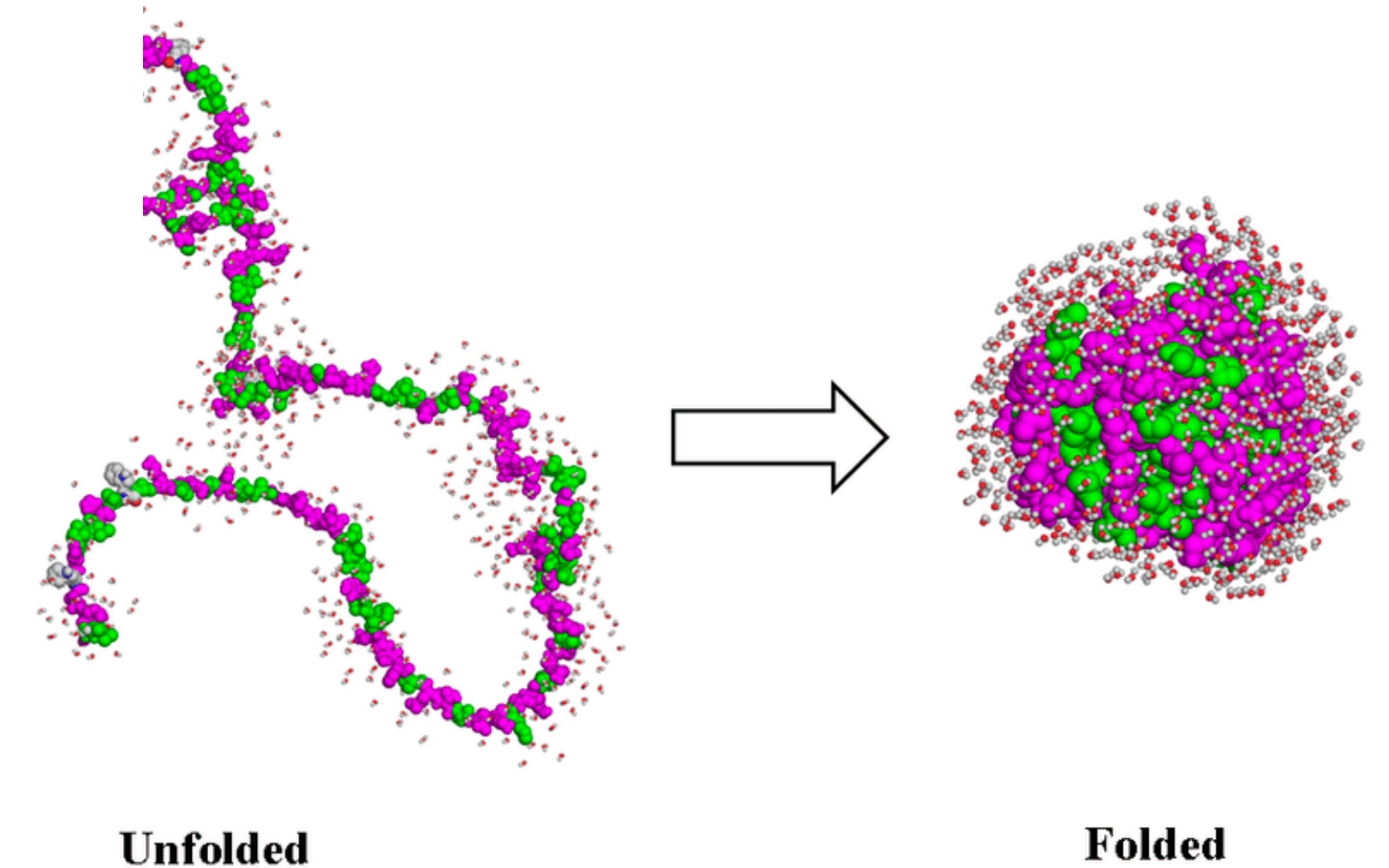
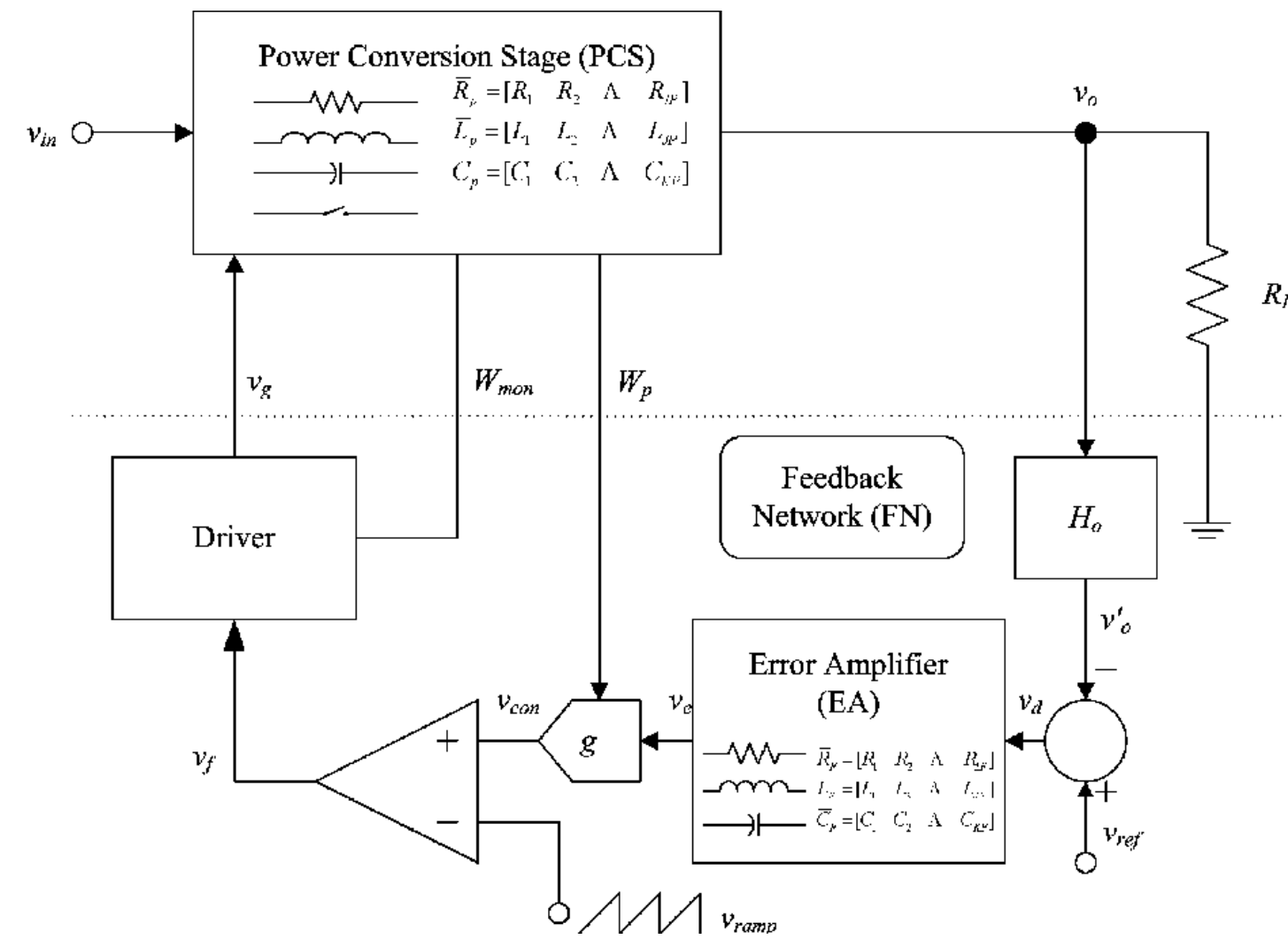
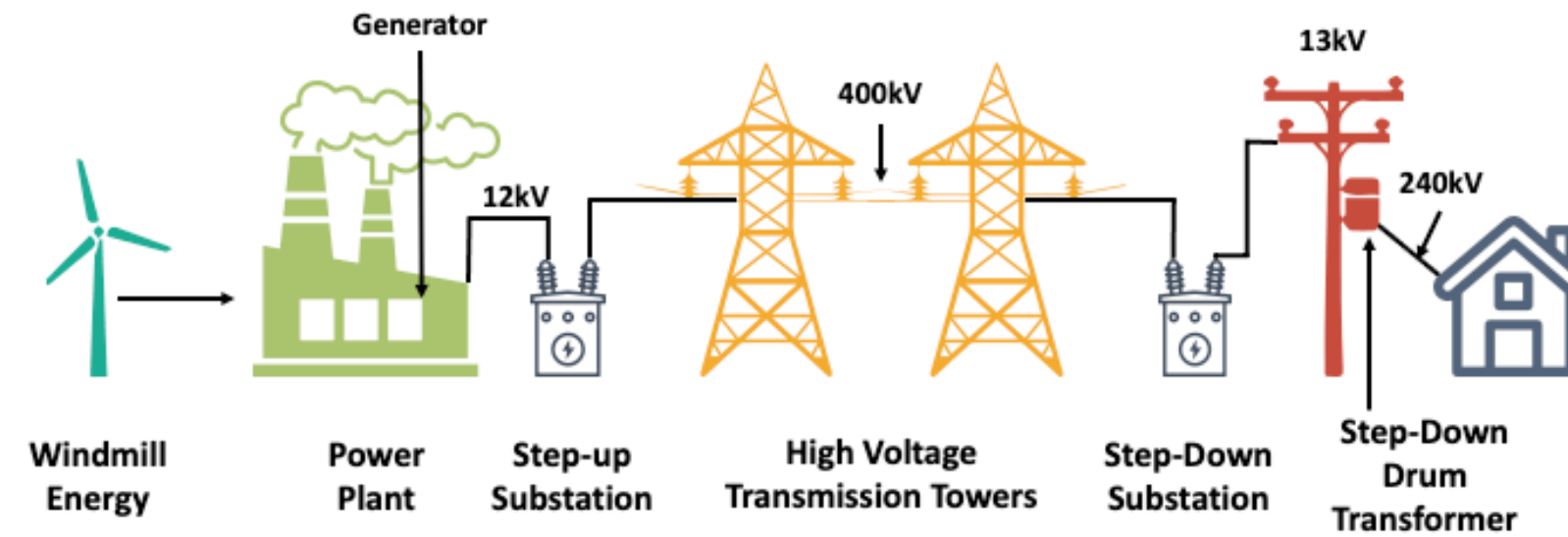

Optimization problems!

Going back to my holidays

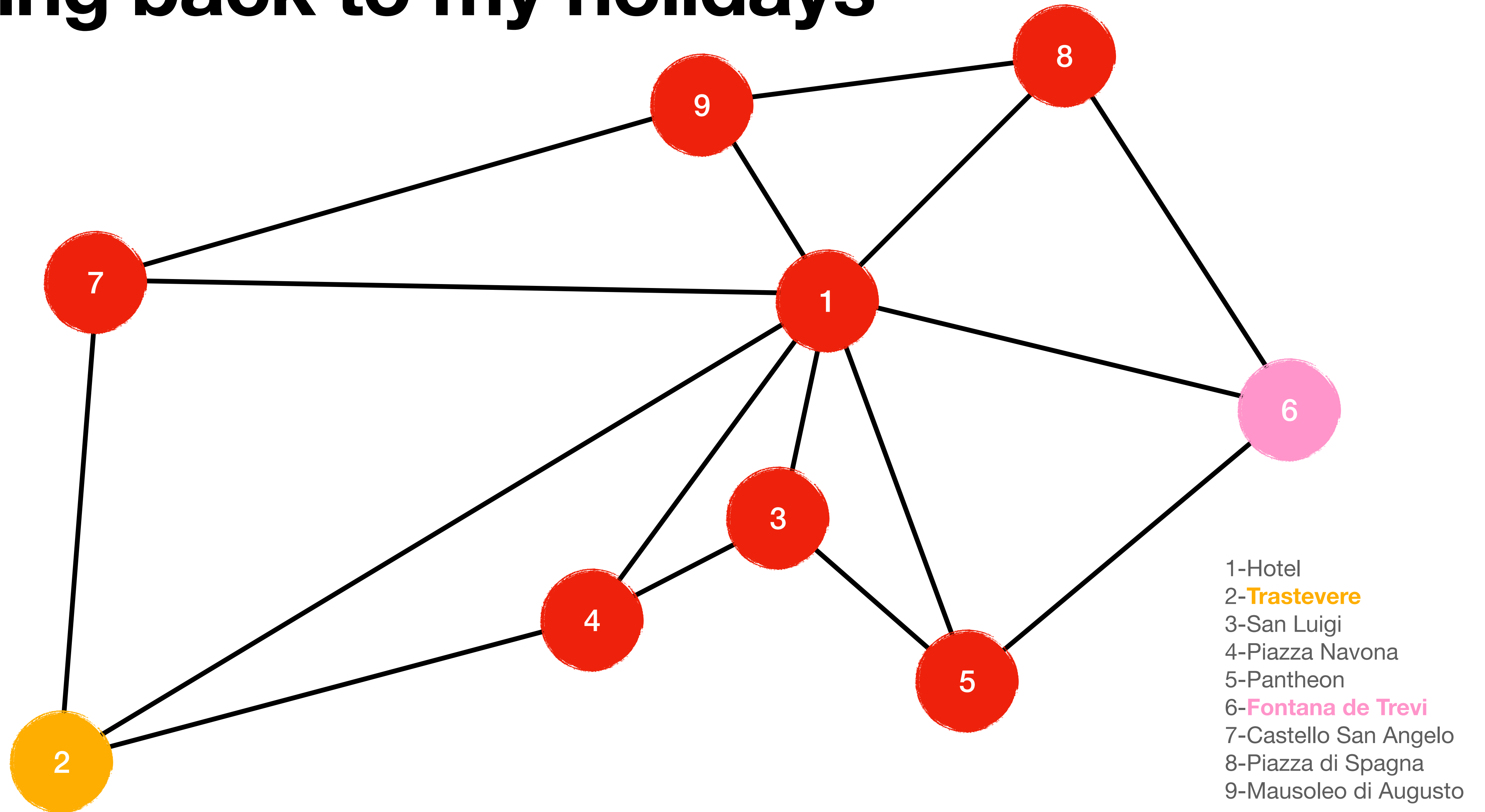

Going back to my holidays

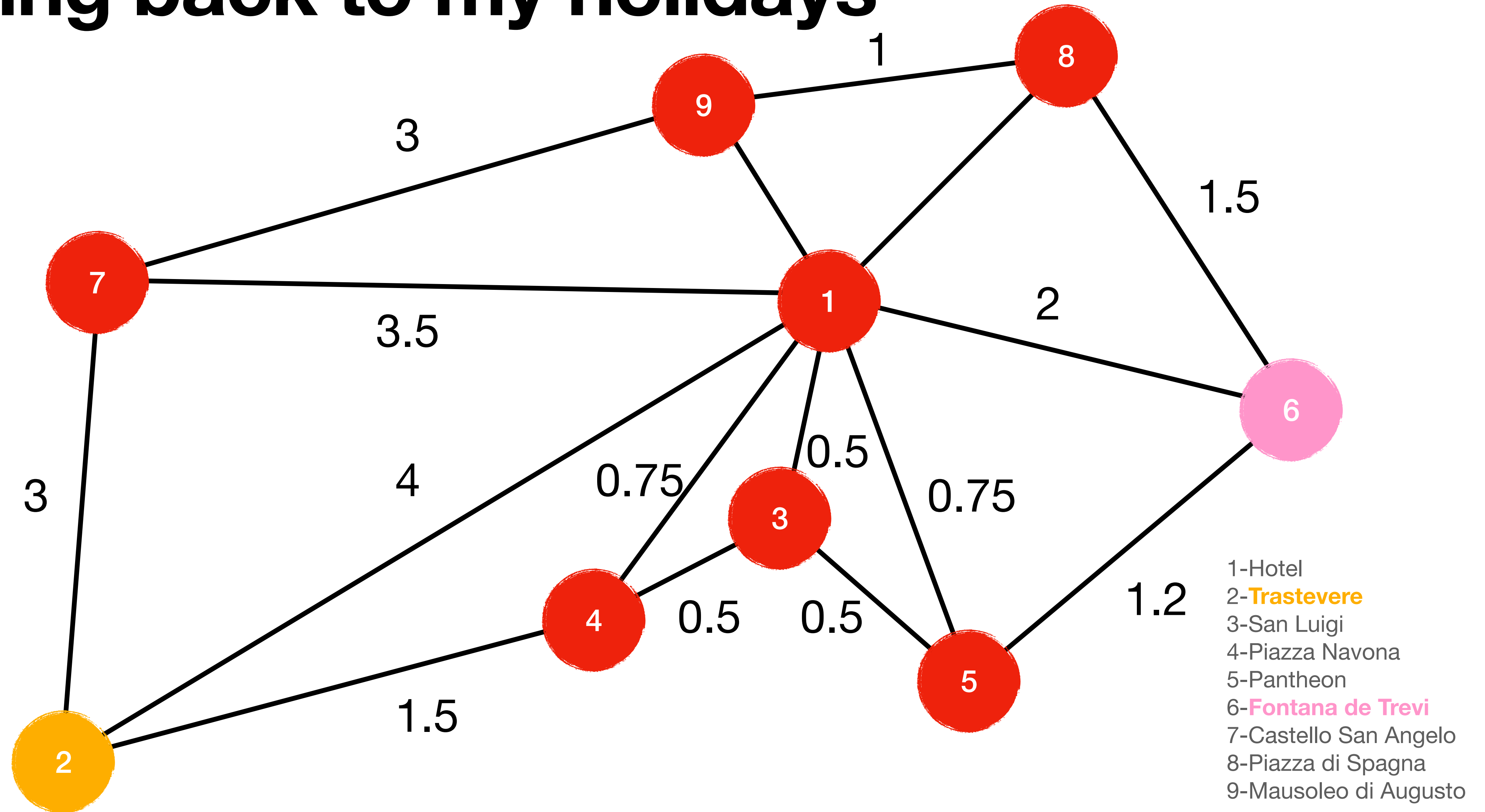

Brute force

- Starting at the node 2 we can calculate the shortest path to the next node connected to it. Then re run the procedure for the next until we find a solution, this is called *Breadth-first search*.

Brute force

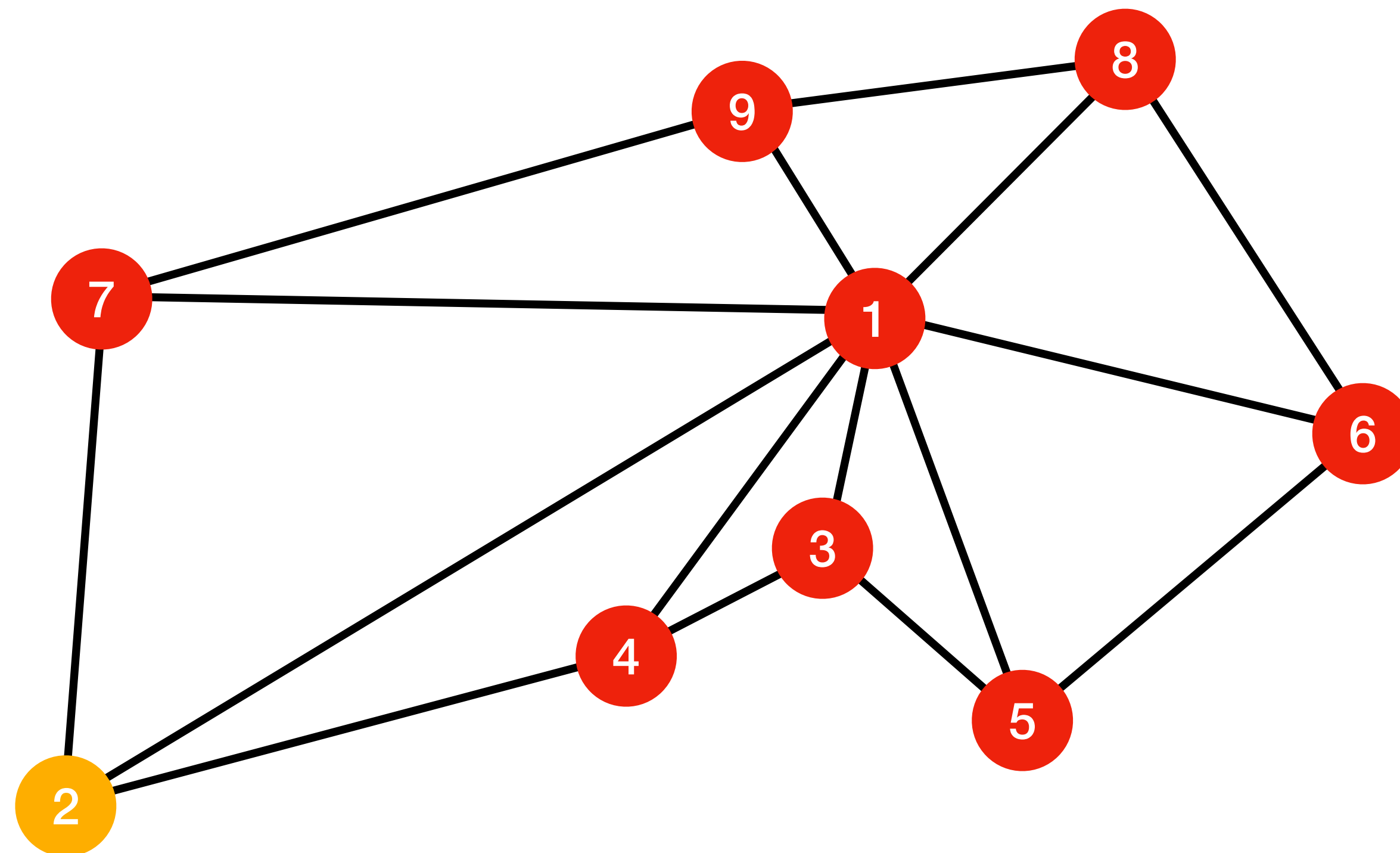

2

Brute force

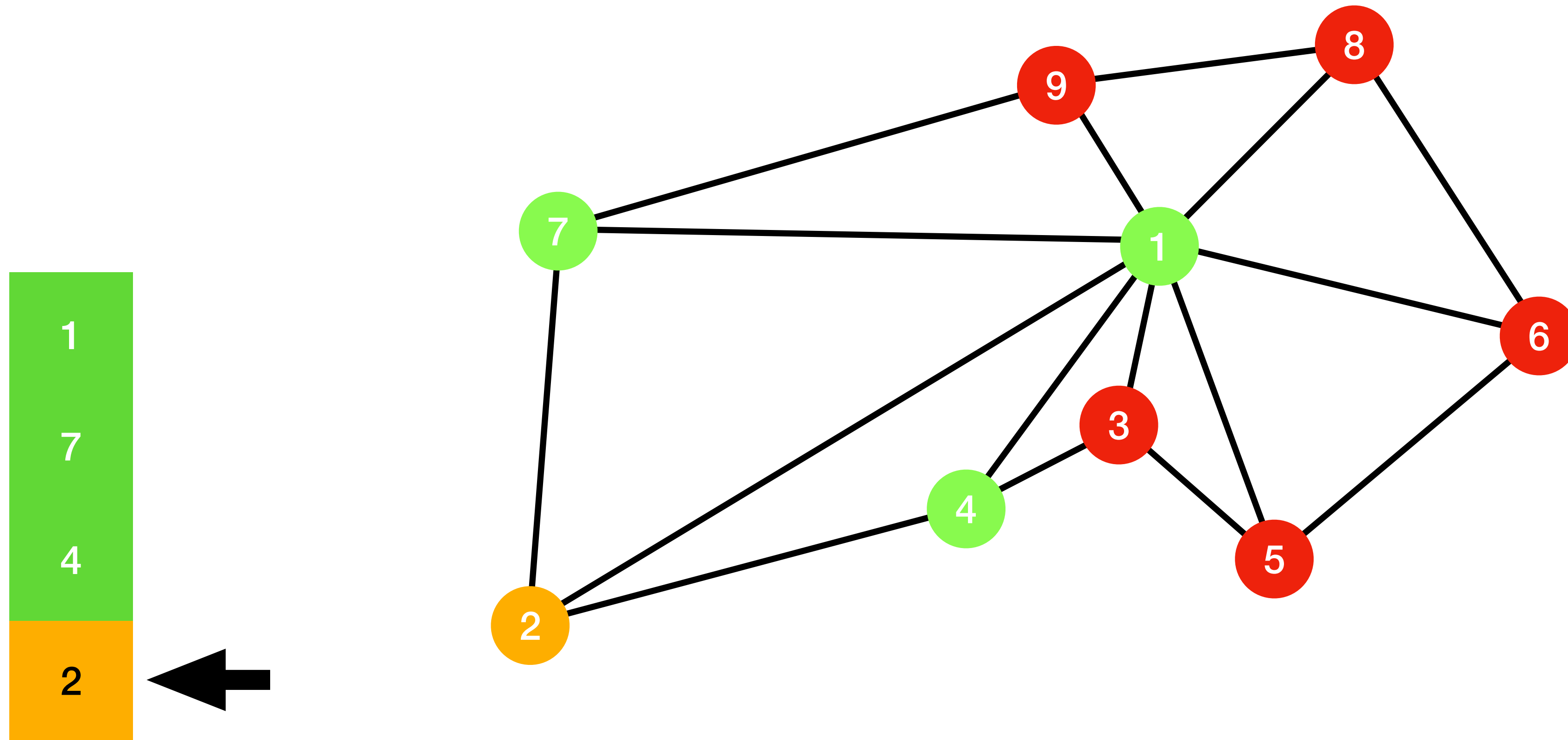

Brute force

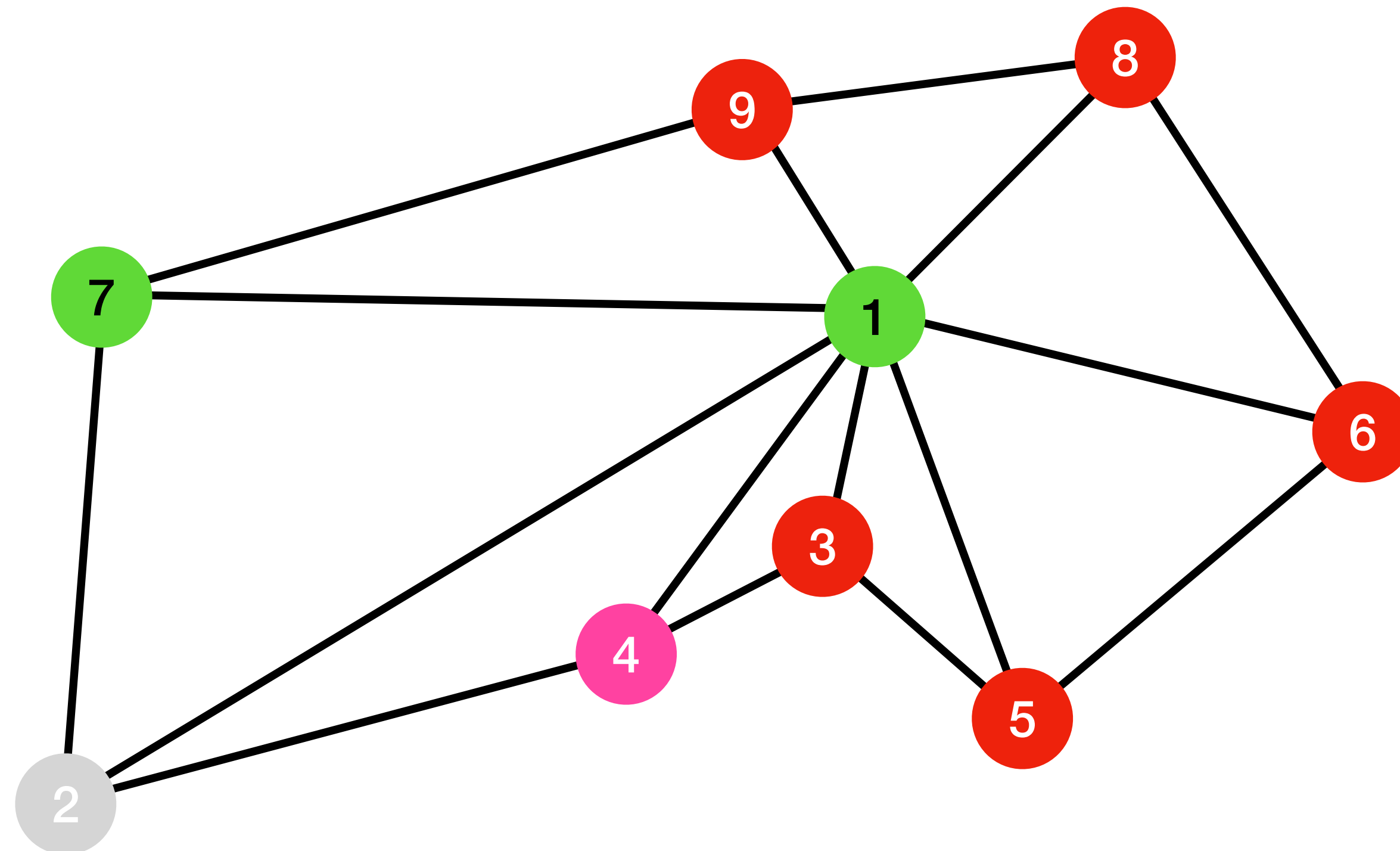
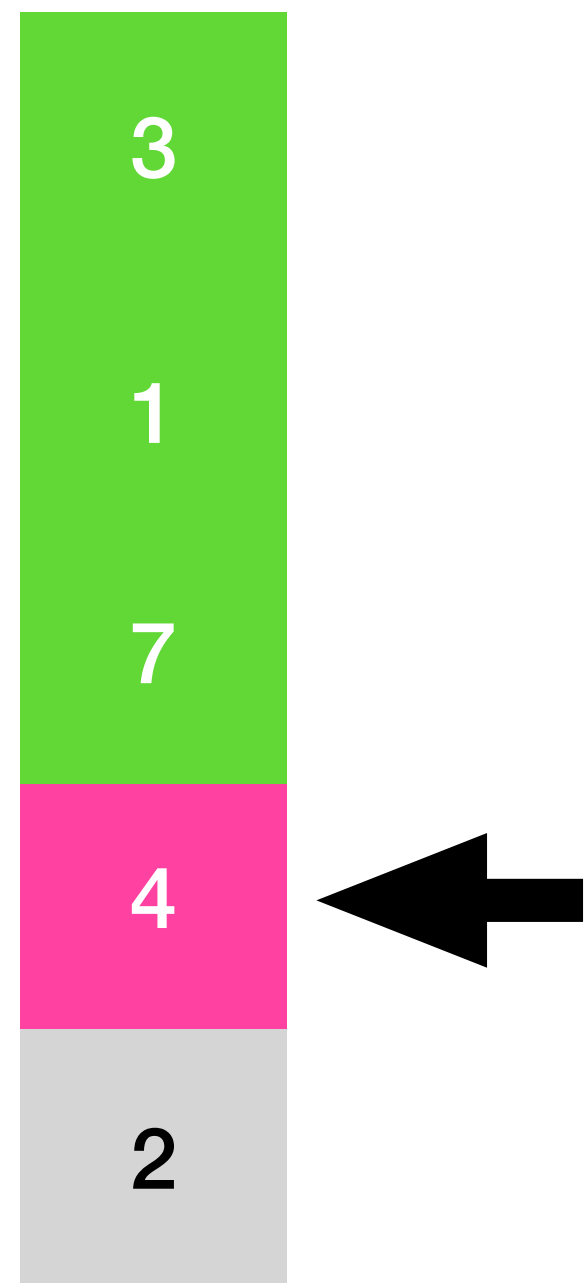

Brute force

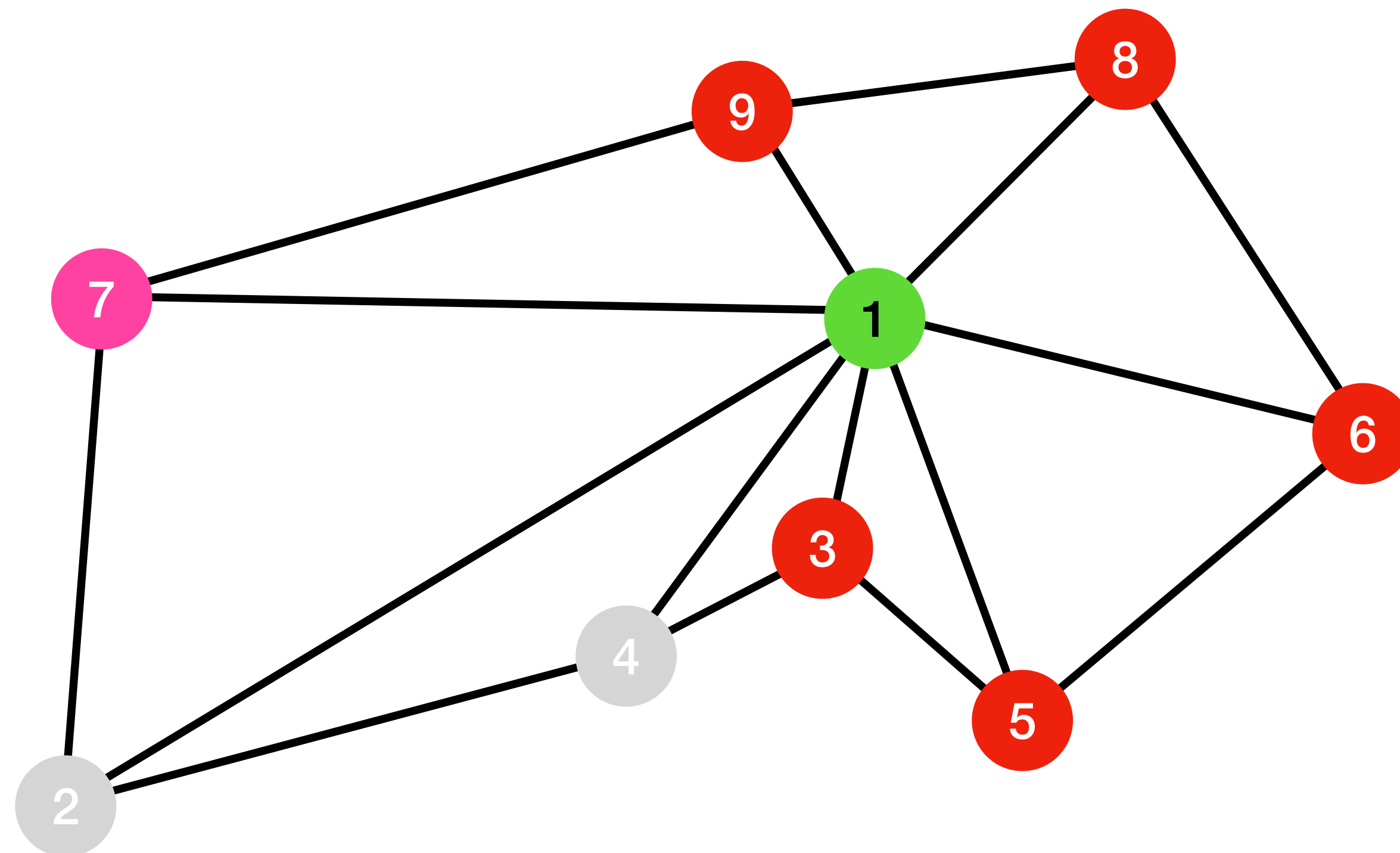
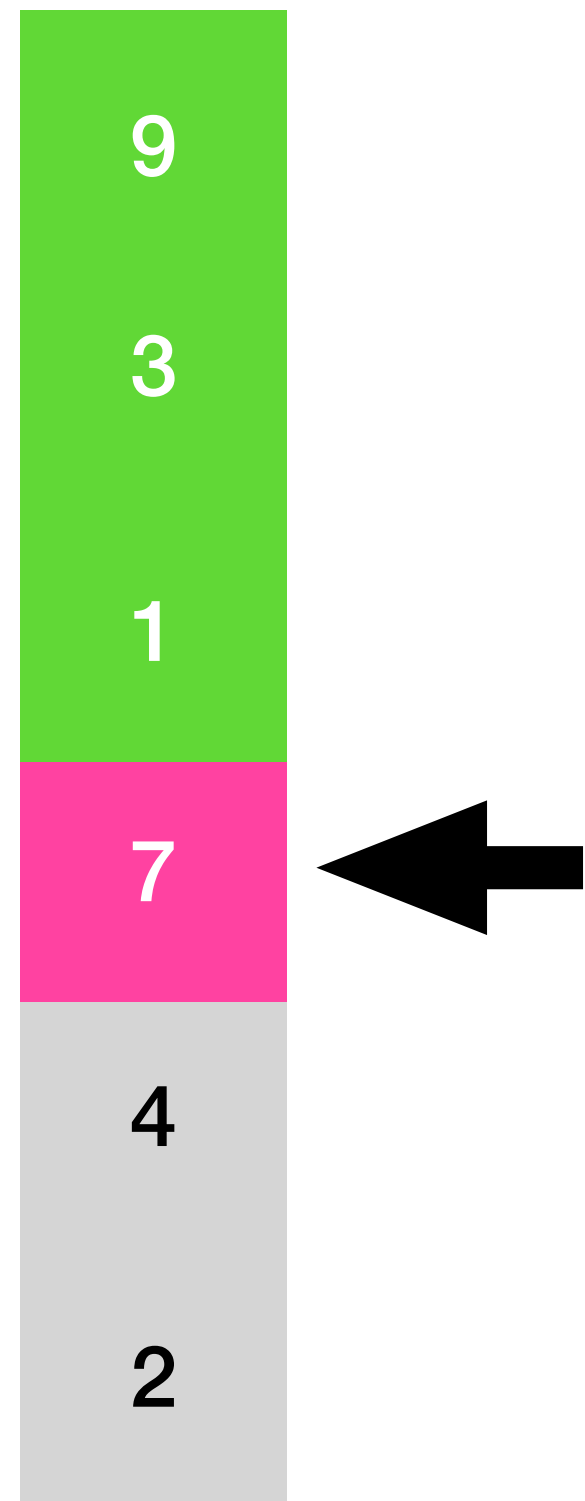

Brute force

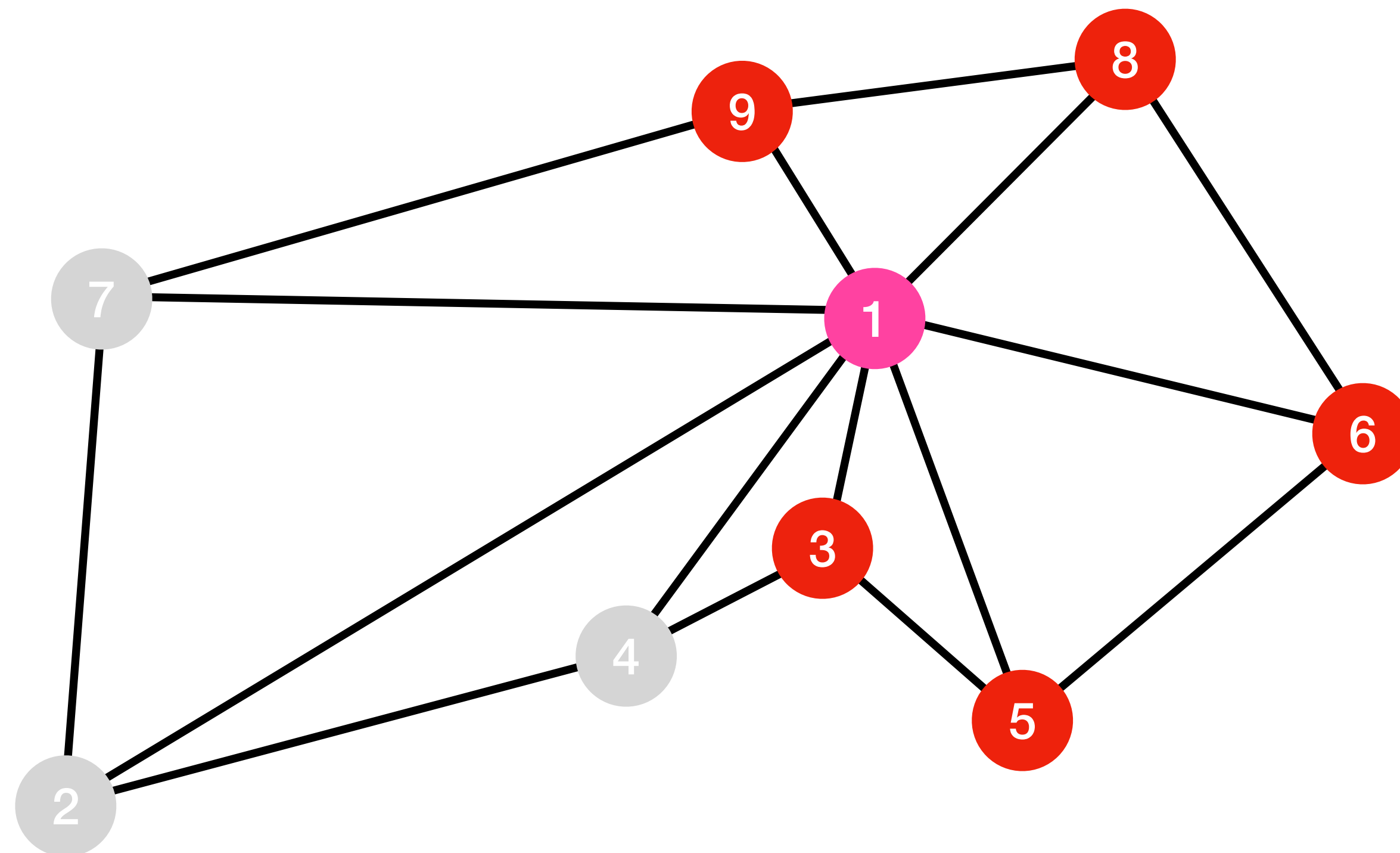
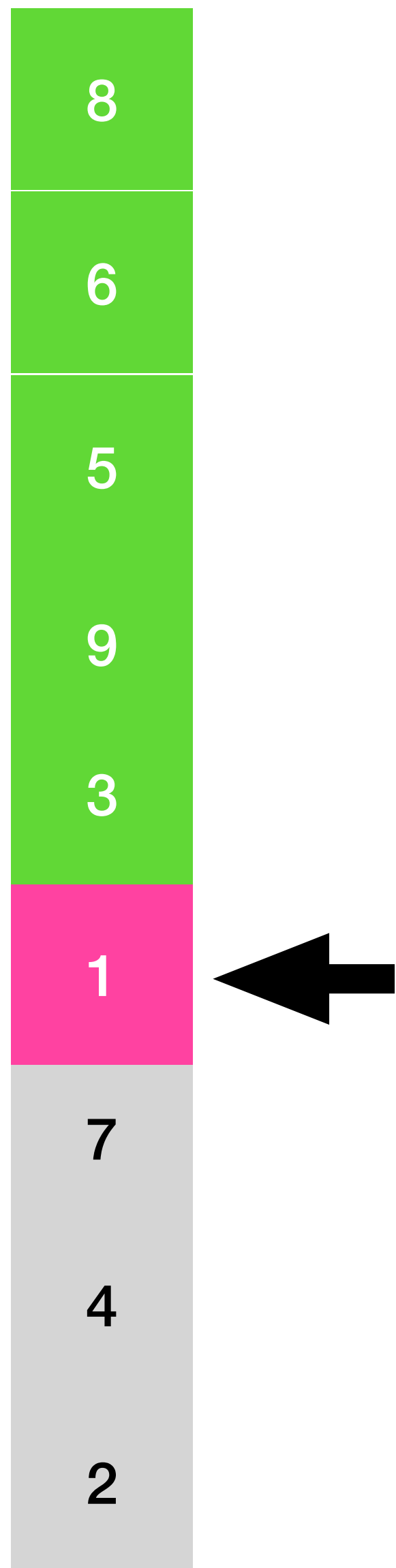

Brute force

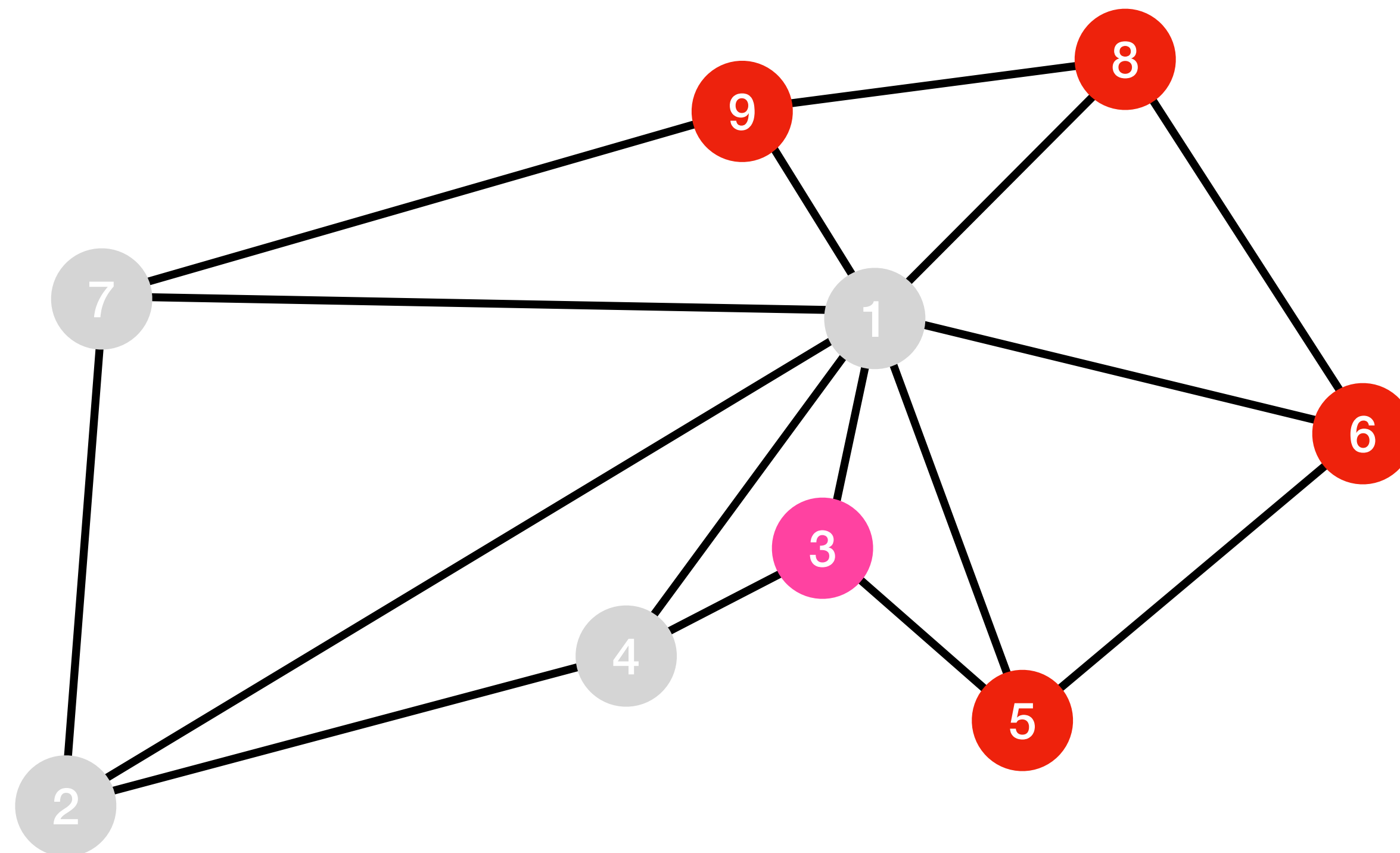
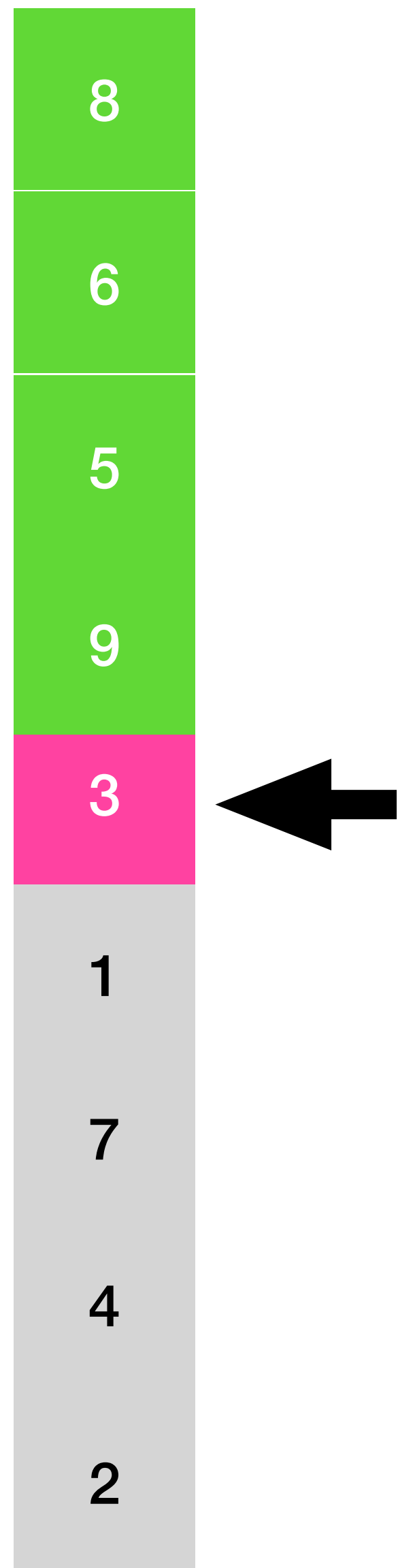

Brute force

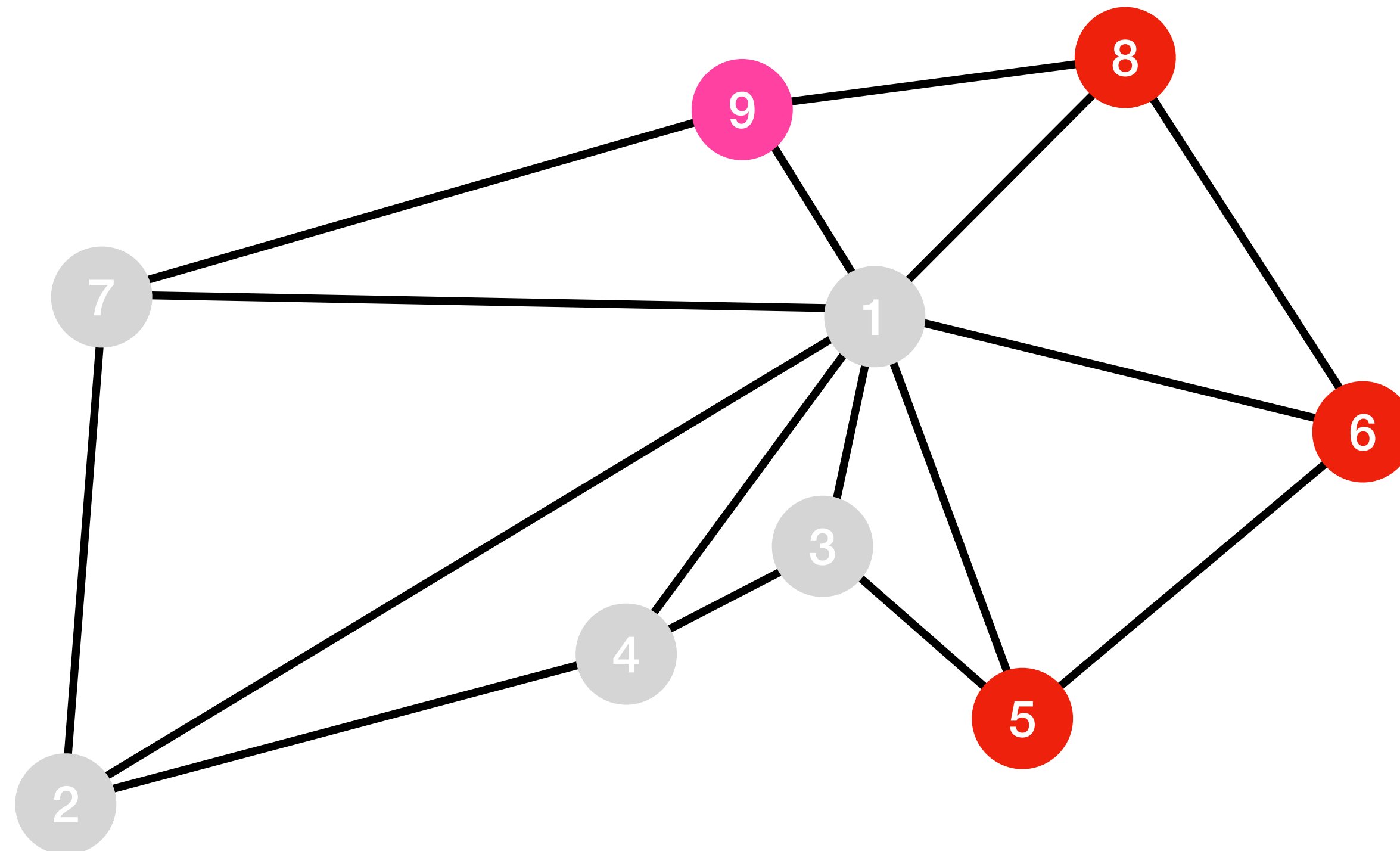
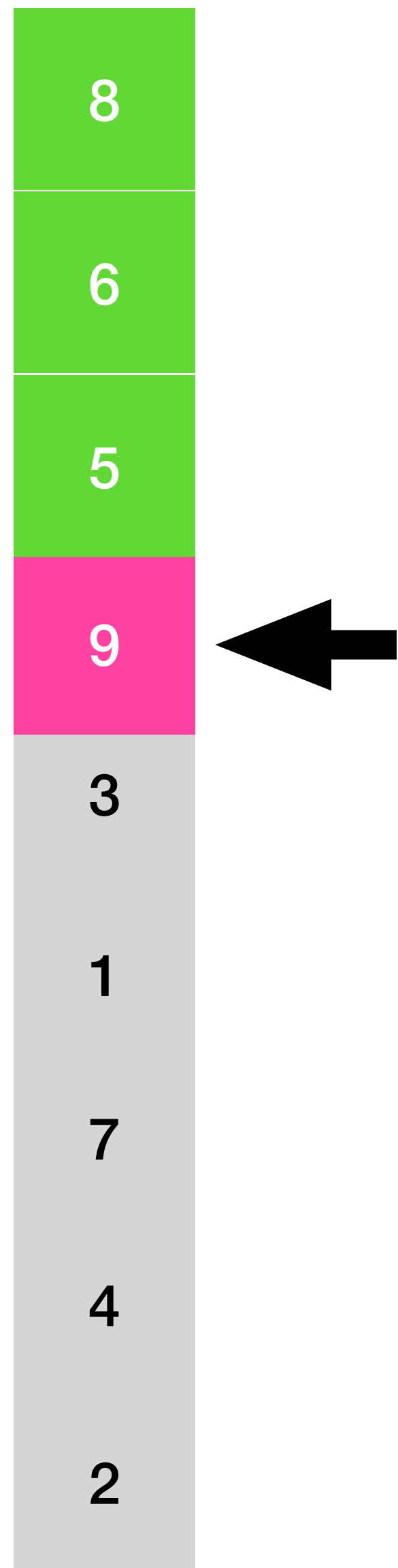

Brute force

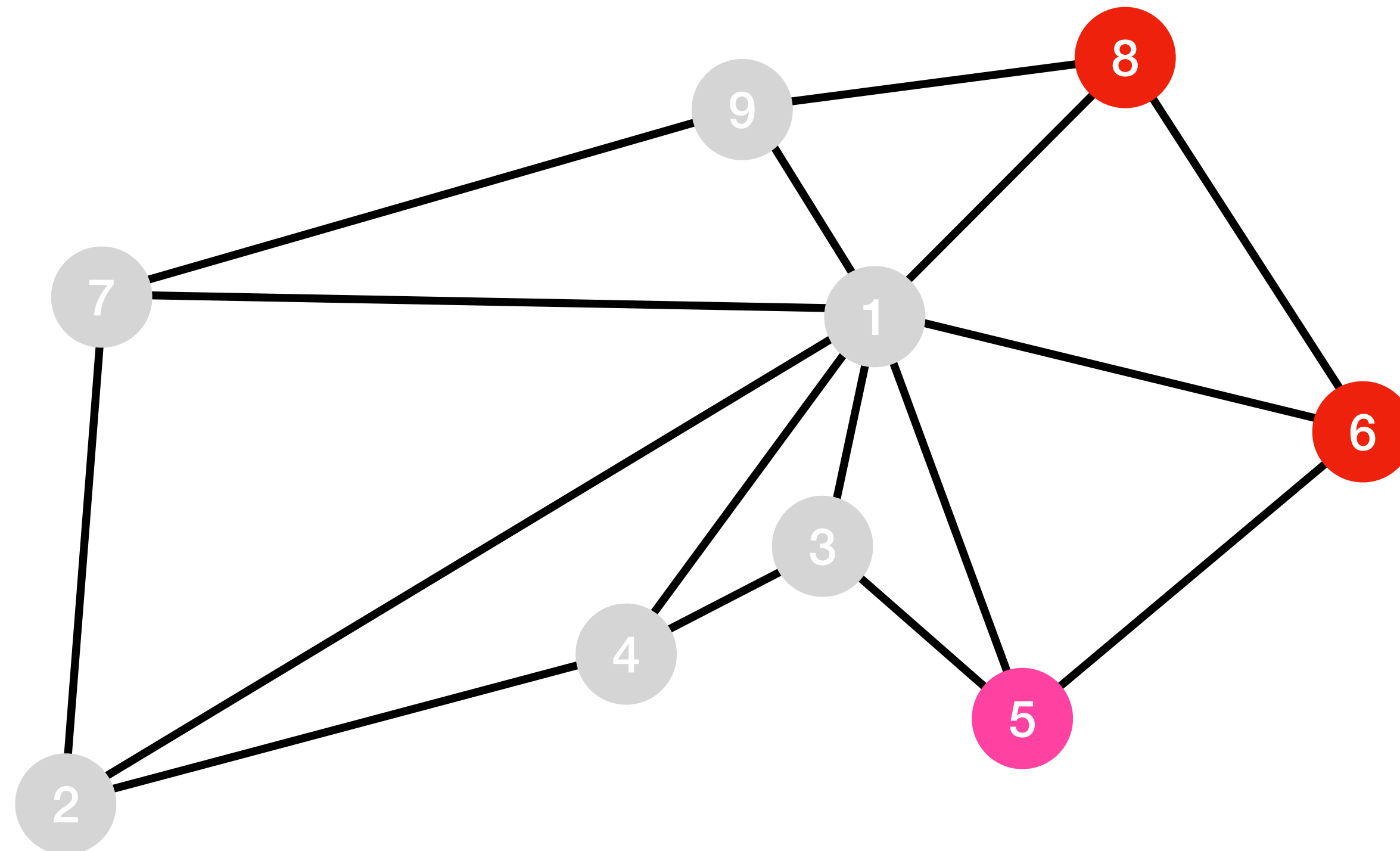
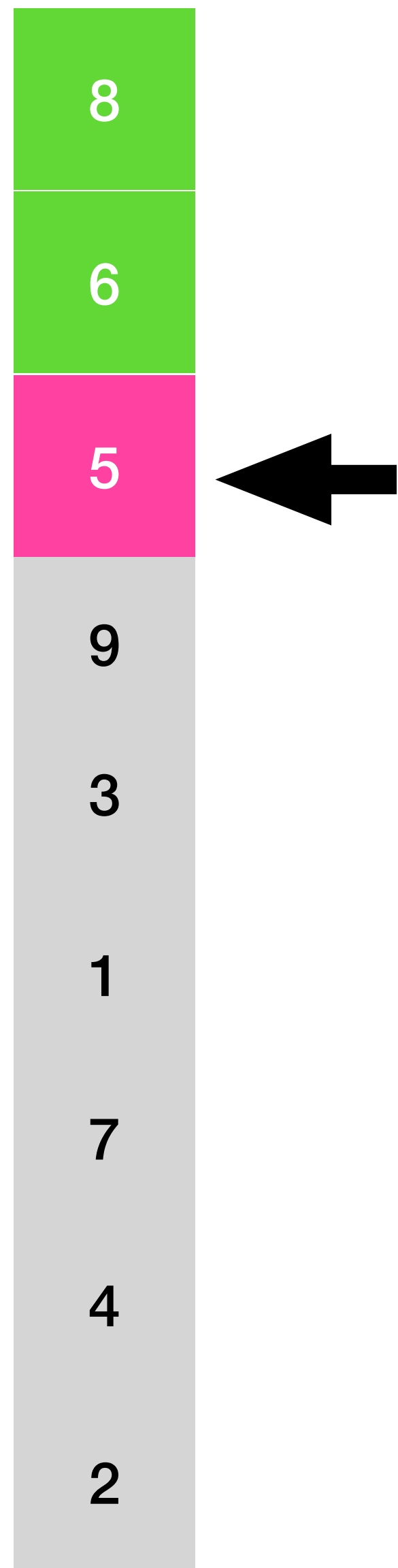

Brute force

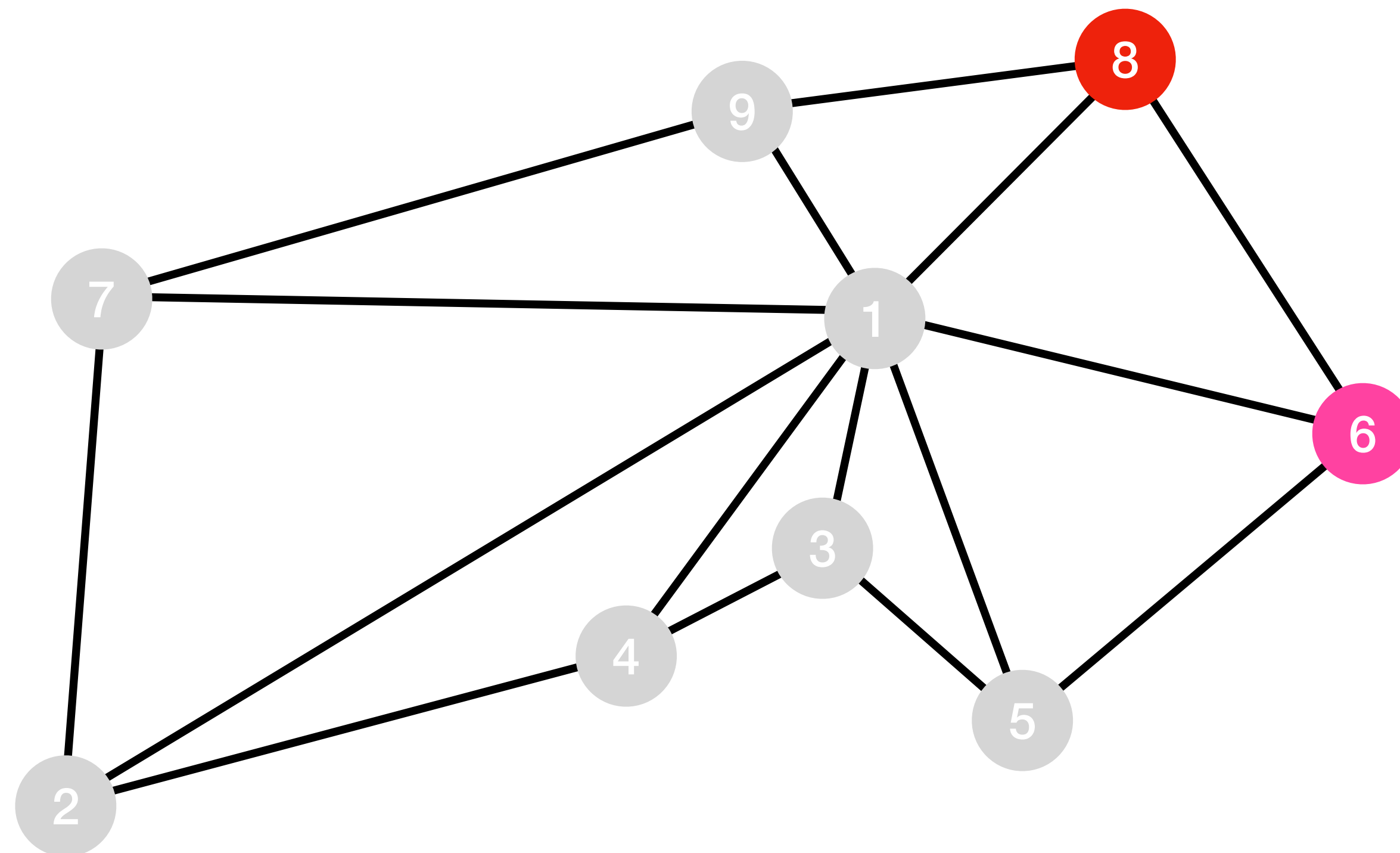
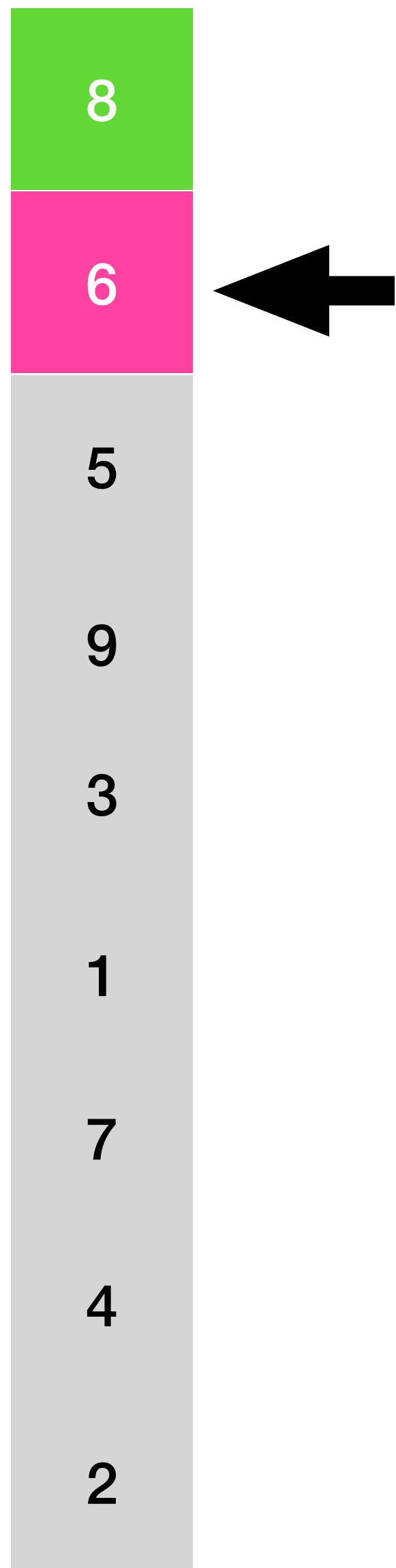

Brute force

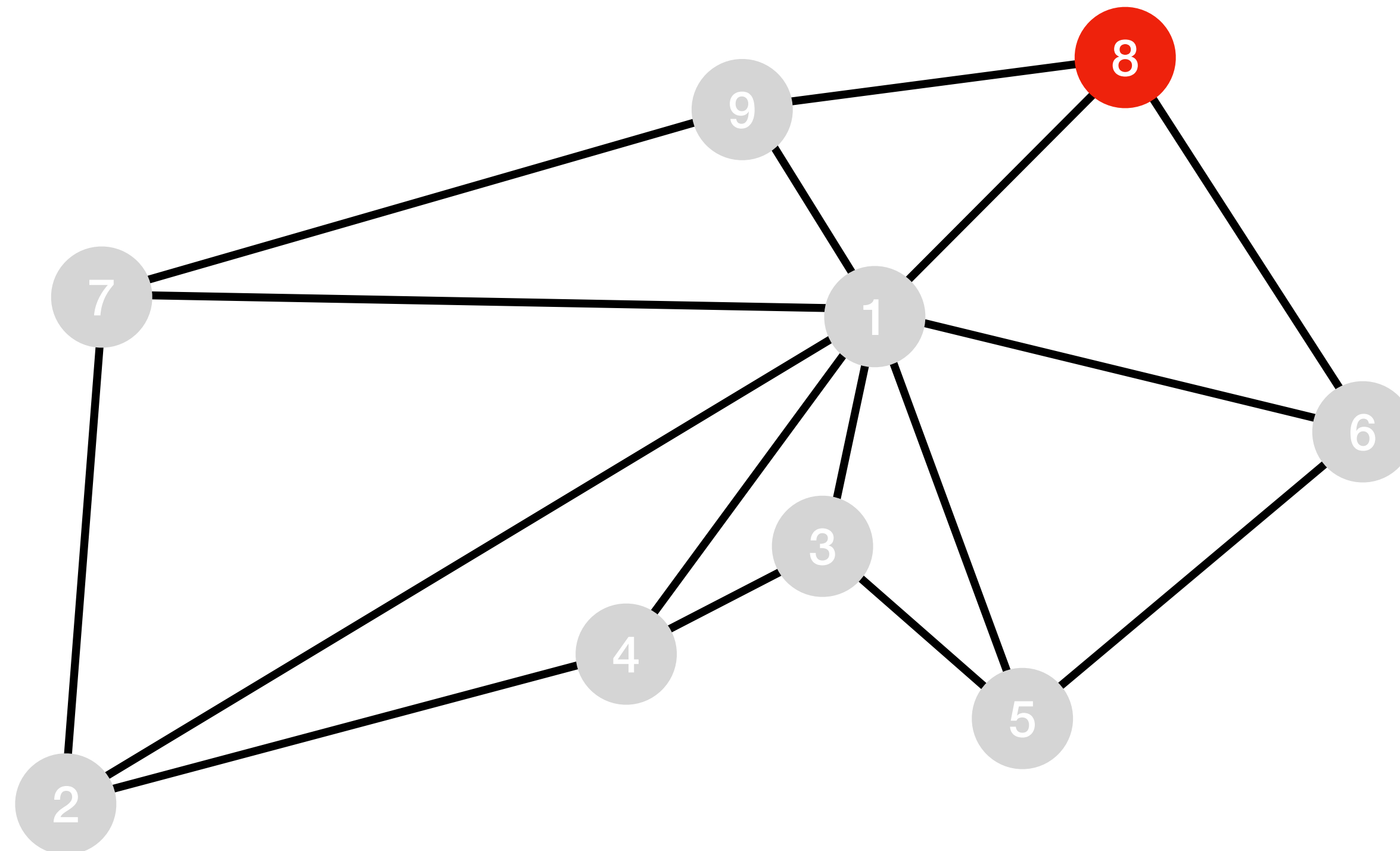
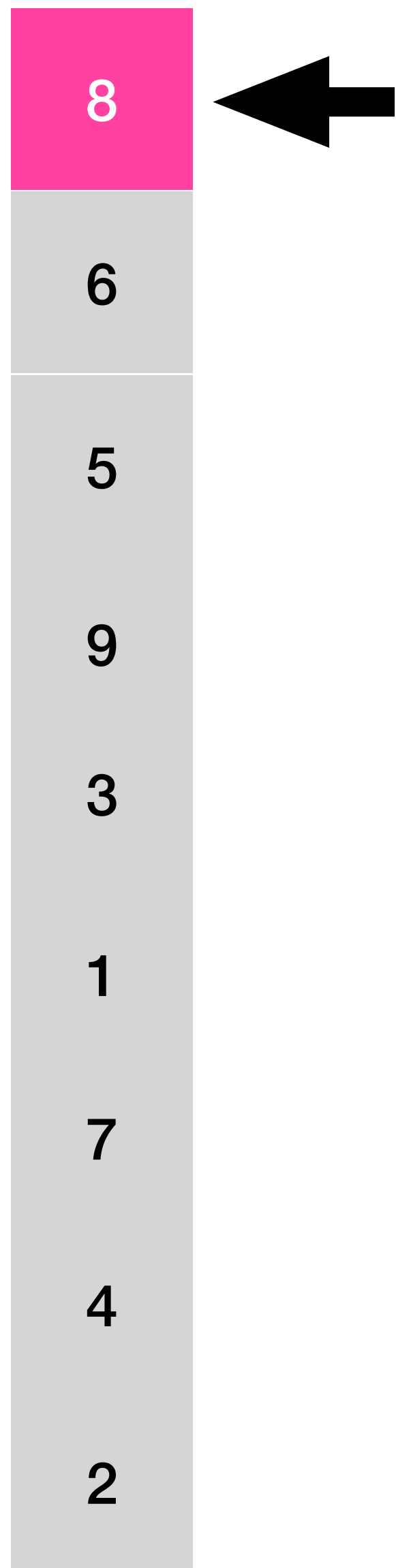

Brute force

Adjacency matrix

	1	2	3	4	5	6	7	8	9
1	0	1	1	1	1	1	1	1	1
2	1	0	-1	1	-1	-1	1	-1	-1
3	1	-1	0	1	1	-1	-1	-1	-1
4	1	1	1	0	-1	-1	-1	-1	-1
5	1	-1	1	-1	0	1	-1	-1	-1
6	1	-1	-1	-1	1	0	-1	1	-1
7	1	1	-1	-1	-1	-1	0	-1	1
8	1	-1	-1	-1	-1	1	-1	0	1
9	1	-1	-1	-1	-1	-1	1	1	0

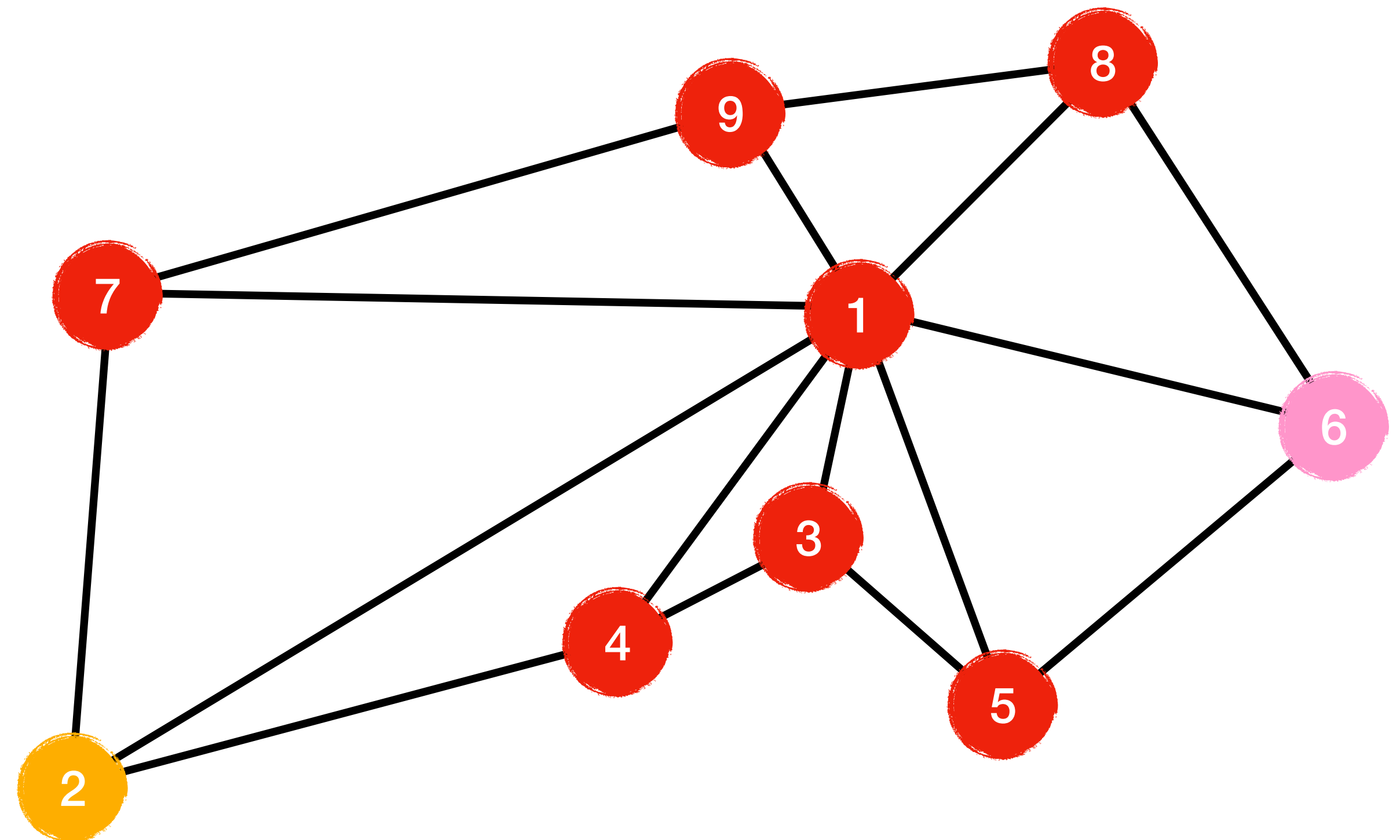



Ants

Swarm Intelligence

Ants

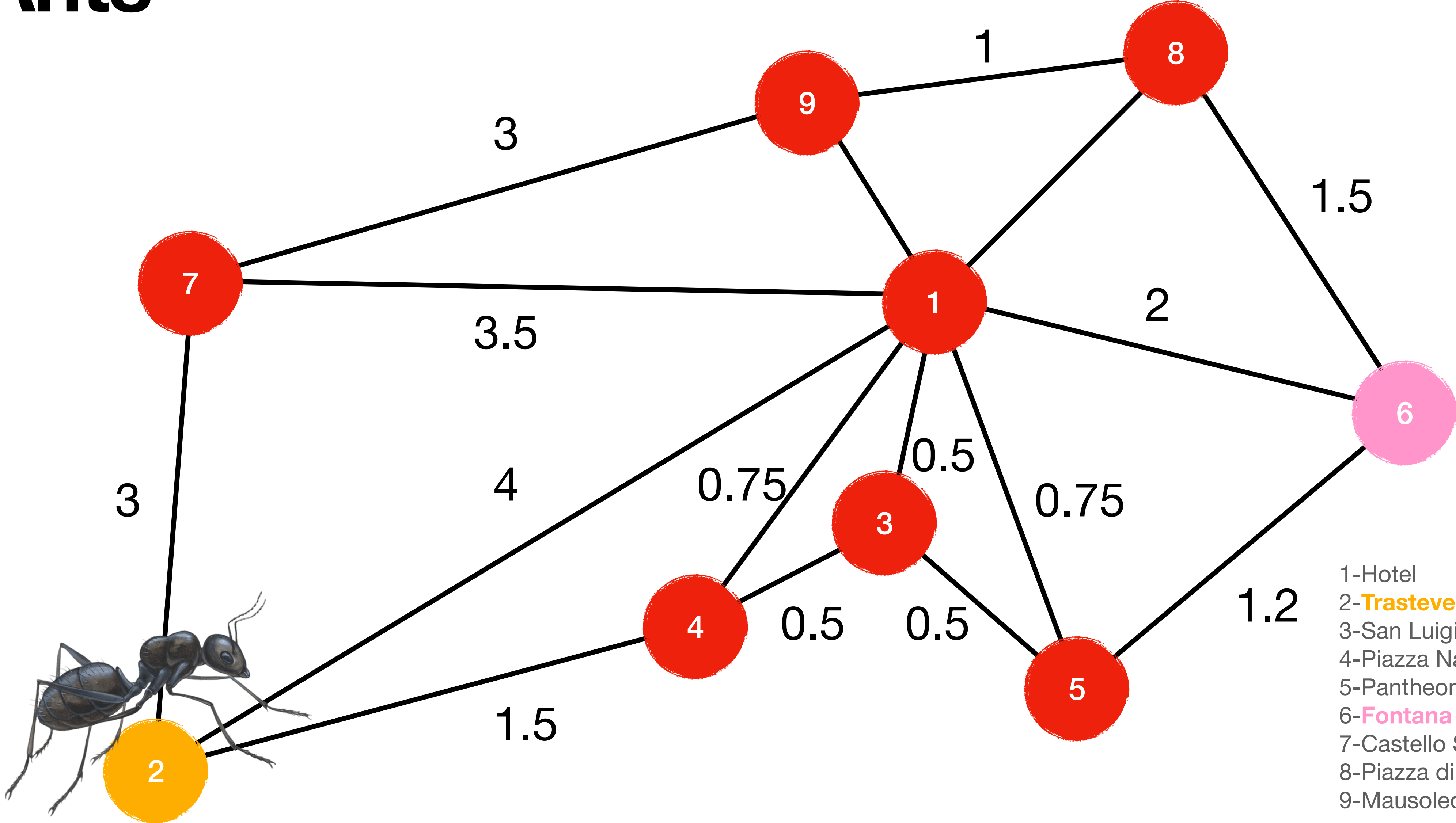

- 1-Hotel
- 2-Trastevere
- 3-San Luigi
- 4-Piazza Navona
- 5-Pantheon
- 6-Fontana de Trevi
- 7-Castello San Angelo
- 8-Piazza di Spagna
- 9-Mausoleo di Augusto

Ants

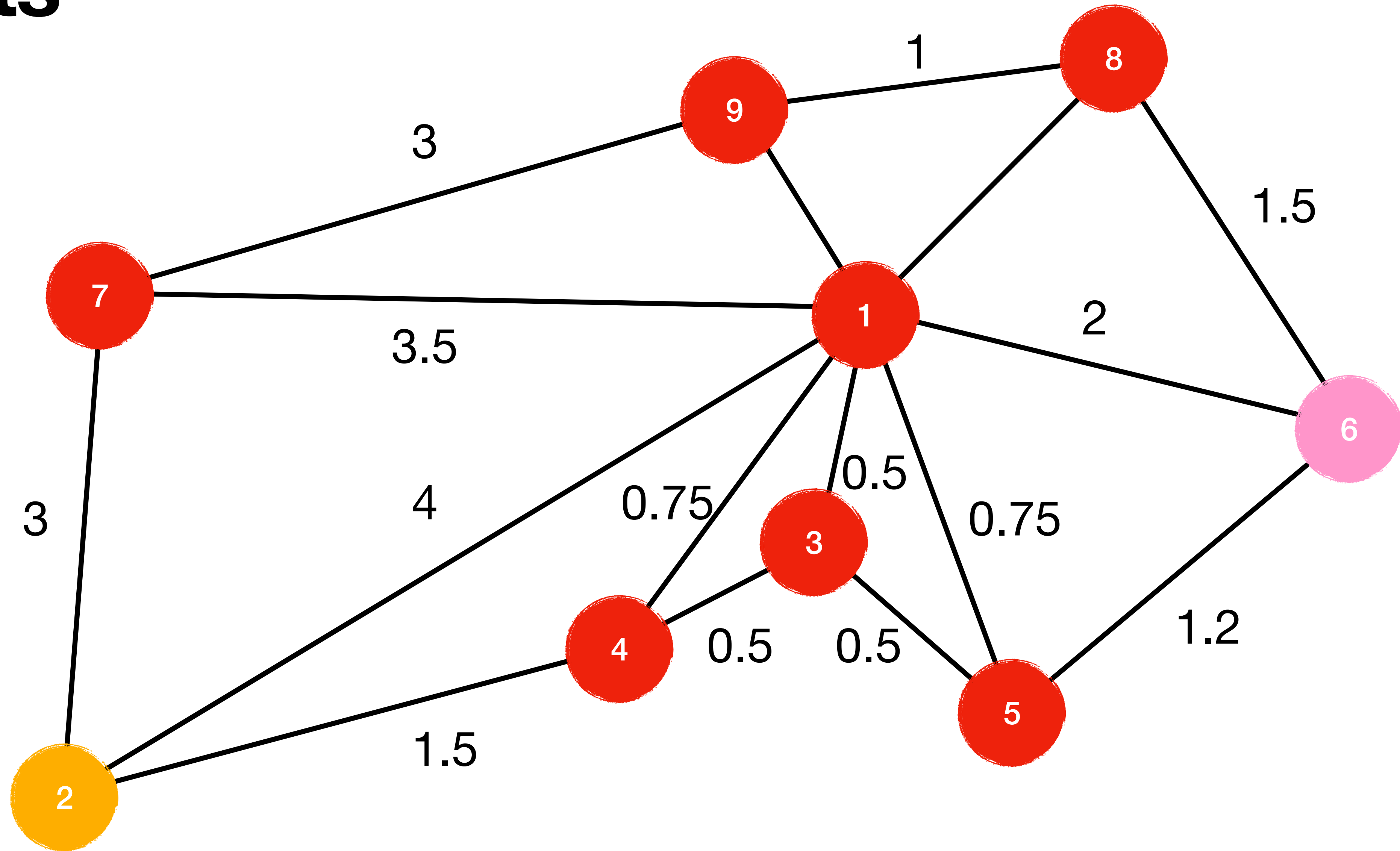

Pheromone trails

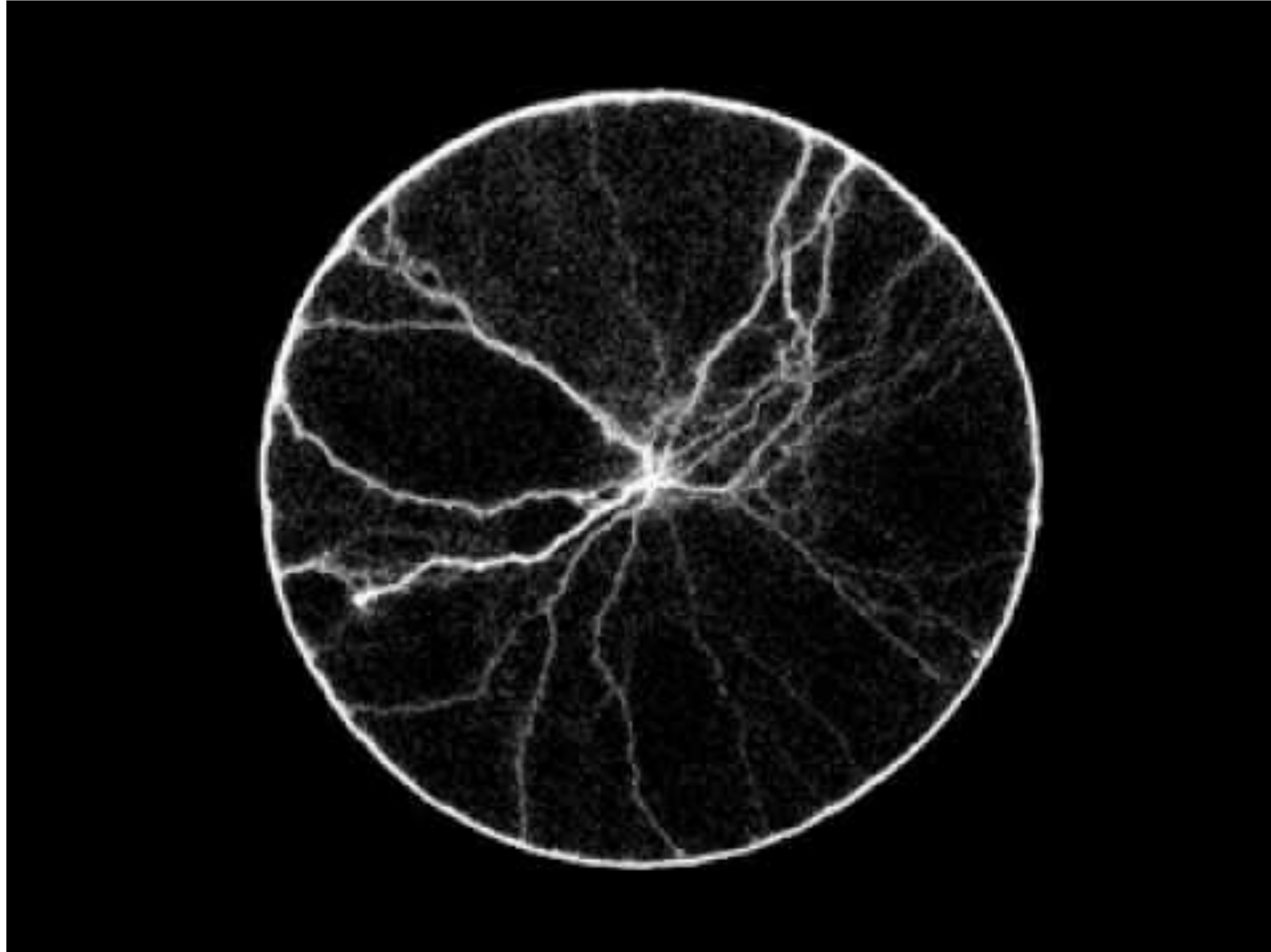
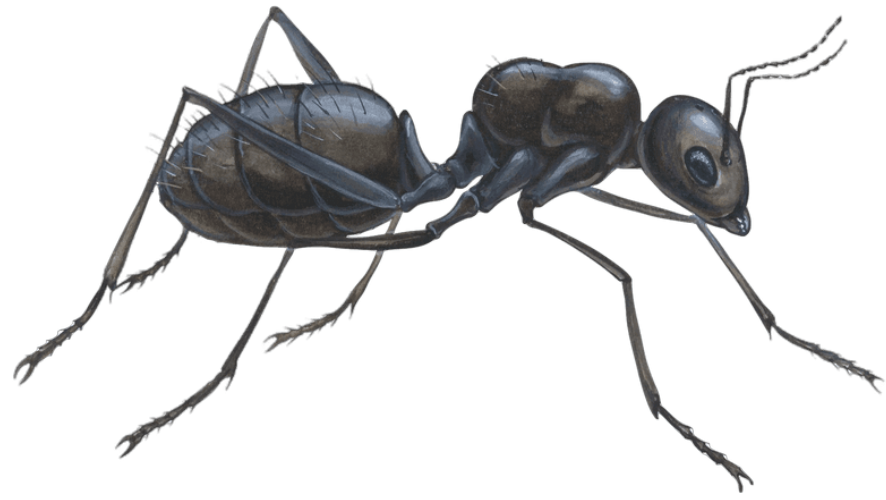

Modelling ant “social” behaviour

... with artificial ants

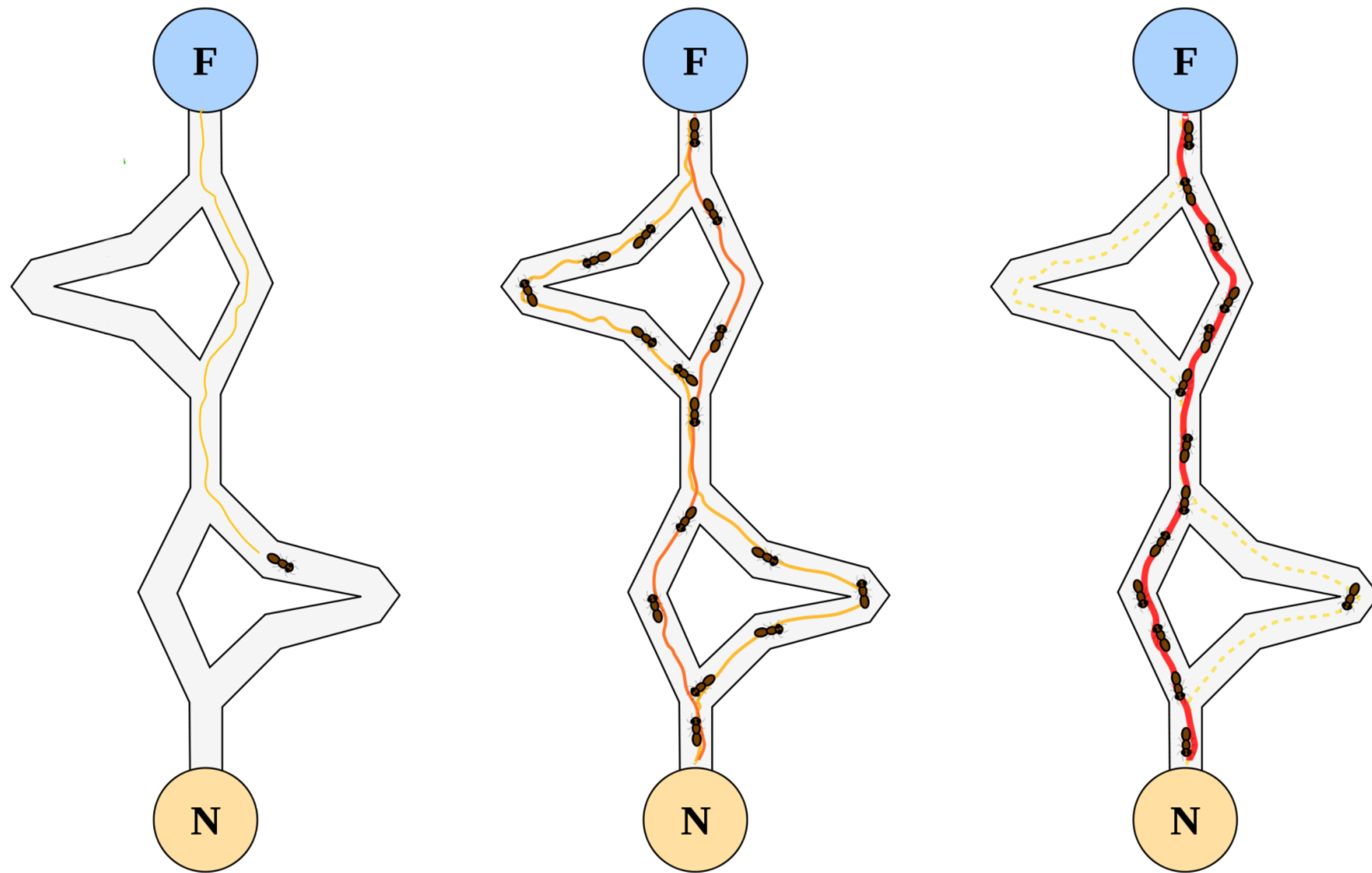

“The shortest path contains more pheromones due high traffic”

Modelling ant “social” behaviour

... with artificial ants

$$p_{ij} = \frac{w_{ij}^{\alpha} \tau_{ij}^{\beta}}{\sum_{\langle i,k \rangle} w_{ik}^{\alpha} \tau_{ik}^{\beta}} \text{ with } 0 < \alpha < 1 \text{ and } \beta \geq 1$$

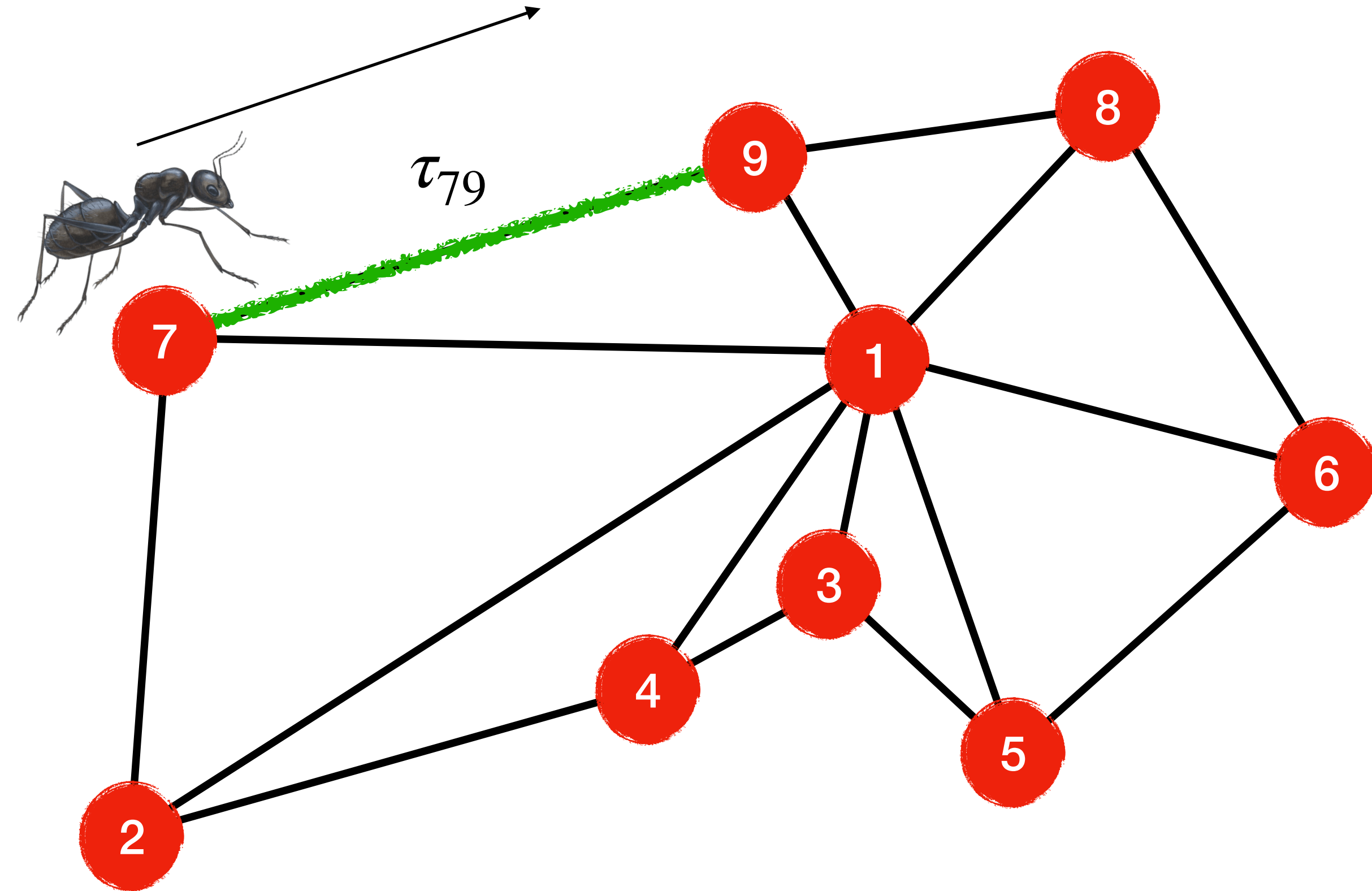

τ_{ij} pheromones laid at ij edge

w_{ij} weight between ij edge

Modelling ant “social” behaviour

... with artificial ants

$$P_{ij} = \frac{w_{ij}^{\alpha} \tau_{ij}^{\beta}}{\sum_{\langle i,k \rangle} w_{ik}^{\alpha} \tau_{ik}^{\beta}} \text{ with } 0 < \alpha < 1 \text{ and } \beta \geq 1$$

Pheromones updates

$$\Delta \tau_{ij,n} = \begin{cases} \frac{Q}{L(P_n)} & \text{if an ant } n \text{ crossed } ij \\ 0 & \text{otherwise} \end{cases}$$

$P_n = \{s, i_1, i_2, \dots, i_k, f\}$ vertex sequence

$$L(P_n) = \sum_{j \in P_n} d_{j,j+1} \text{ path distance}$$

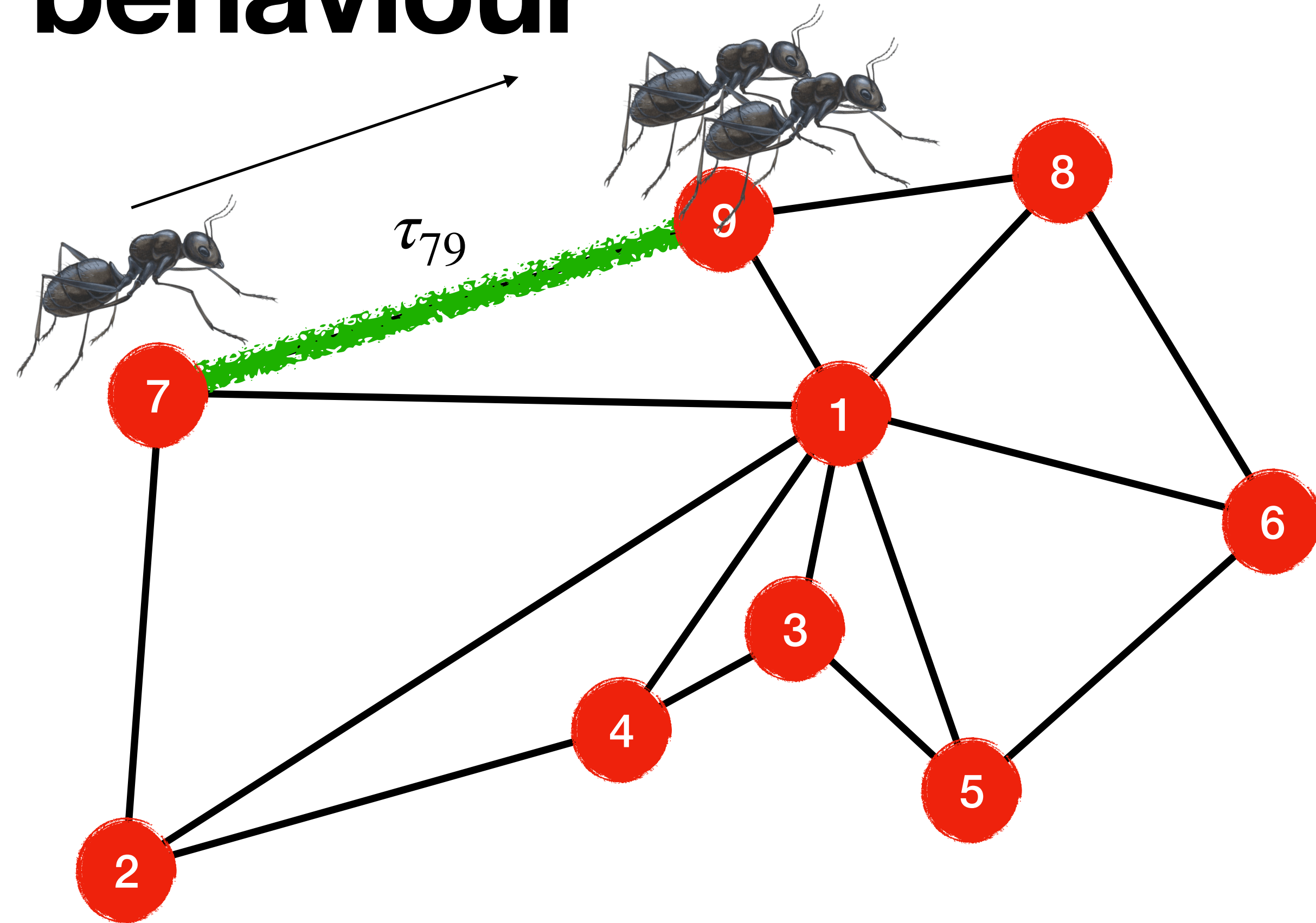

τ_{ij} pheromones laid at ij edge

w_{ij} weight between ij edge

Modelling ant “social” behaviour

... with artificial ants

Pheromones updates

$$\tau_{ij} = (1 - \rho)\tau_{ij} + \sum_{n \in \bar{ij}} \Delta\tau_{ij,n}$$

$\sum_{\bar{ij}}$ sum over all the ants that reached f

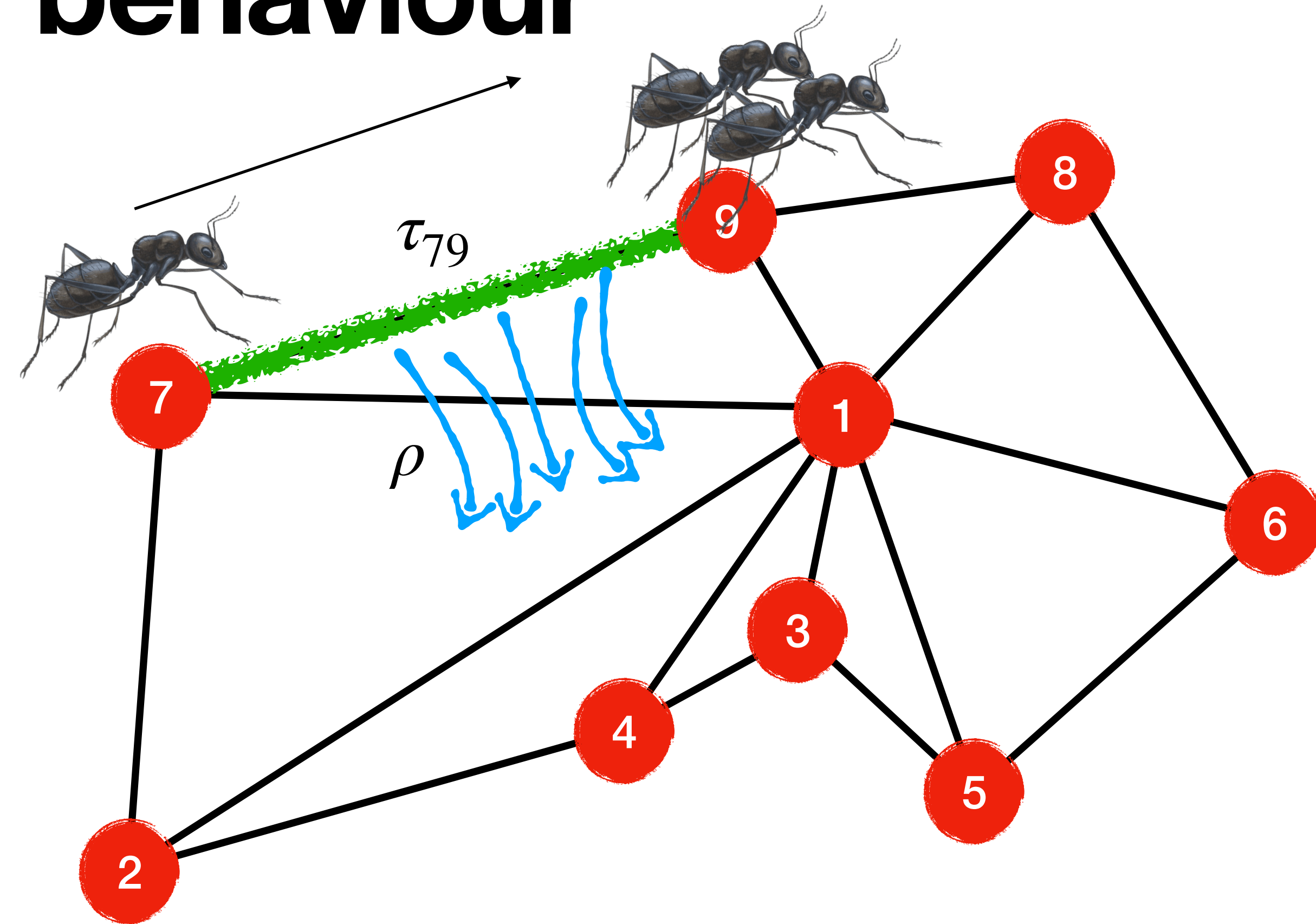

τ_{ij} pheromones laid at ij edge

w_{ij} weight between ij edge

ρ evaporation rate

Ants in action

- Adjacency Matrix
- Weight Matrix
- Pheromone Matrix

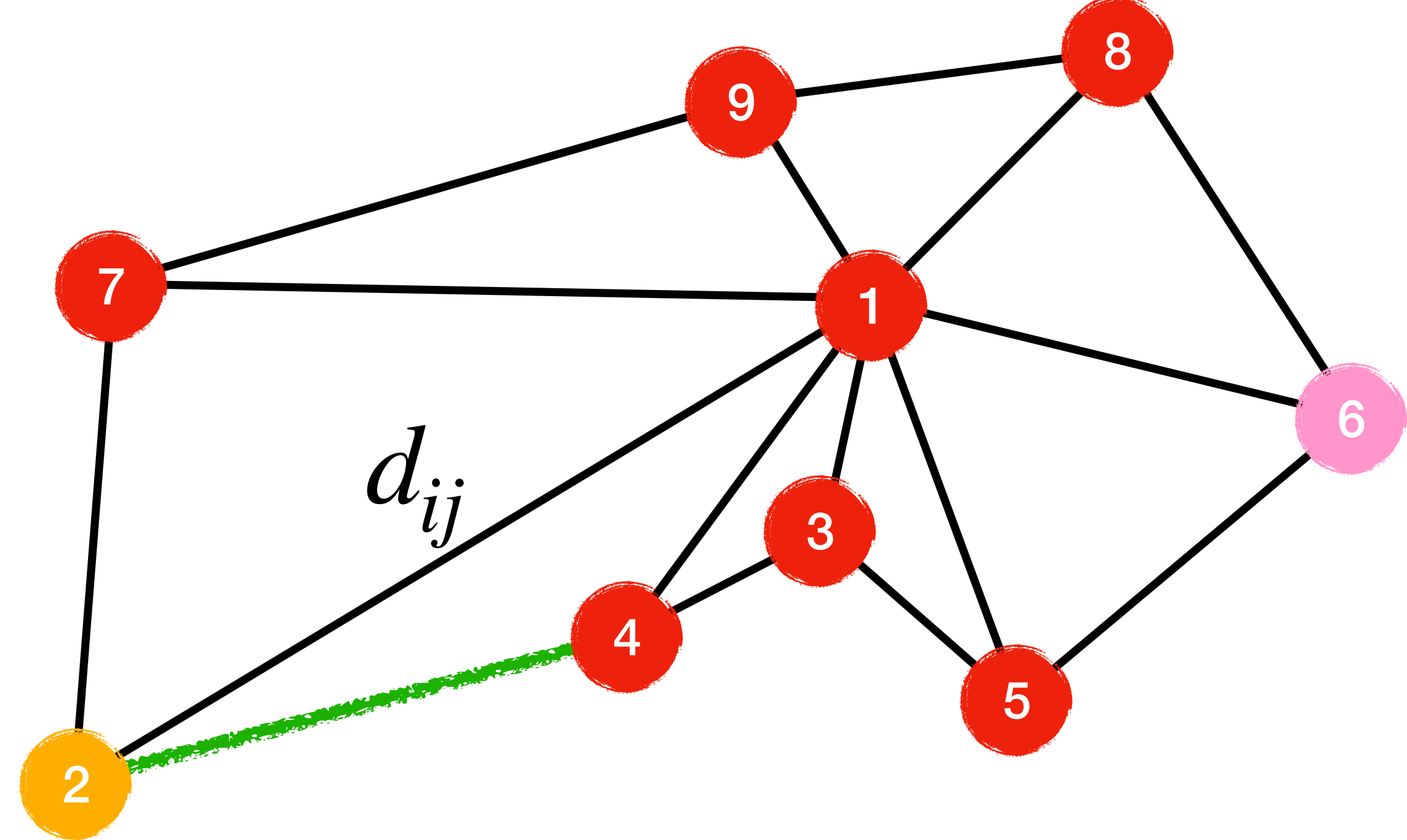

Adjacency Matrix

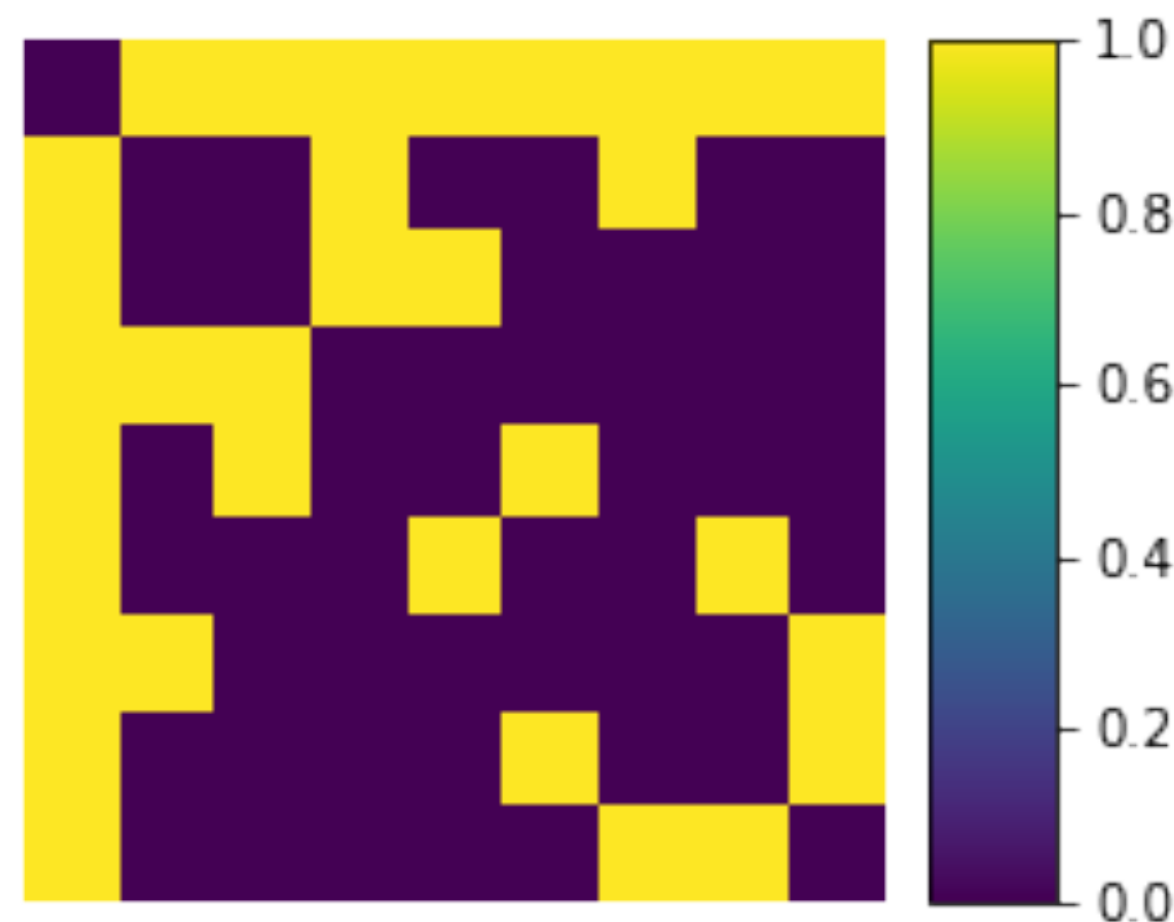

Weight Matrix := d_{ij}^{-1}

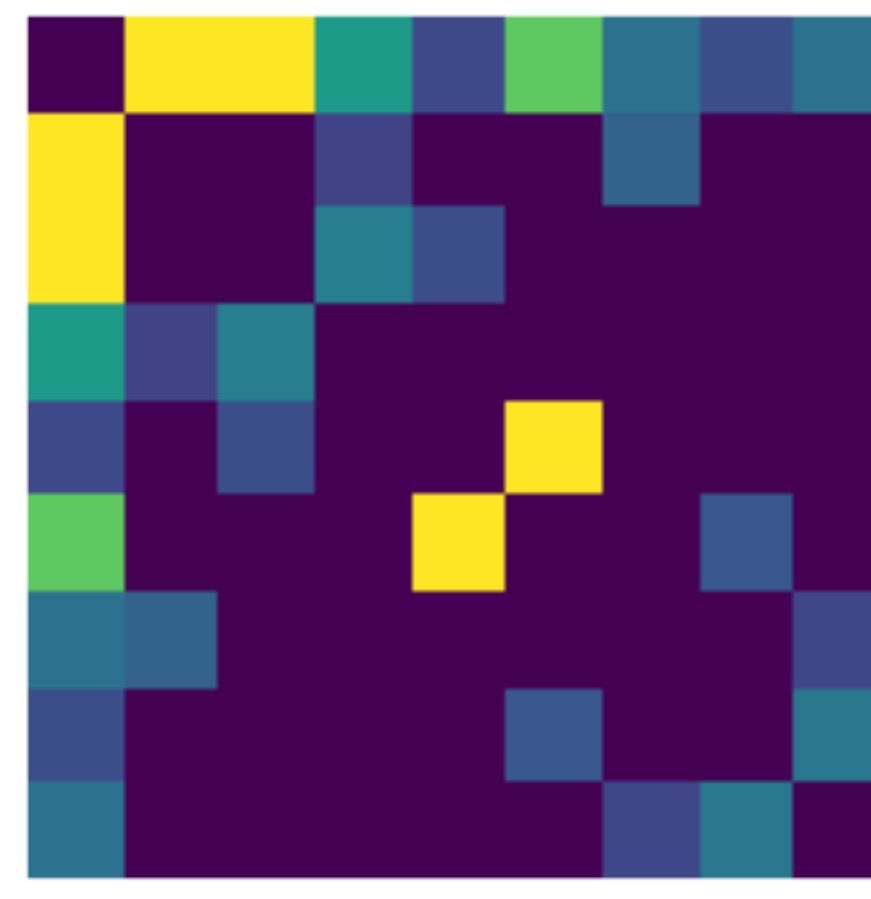

Pheromone Matrix

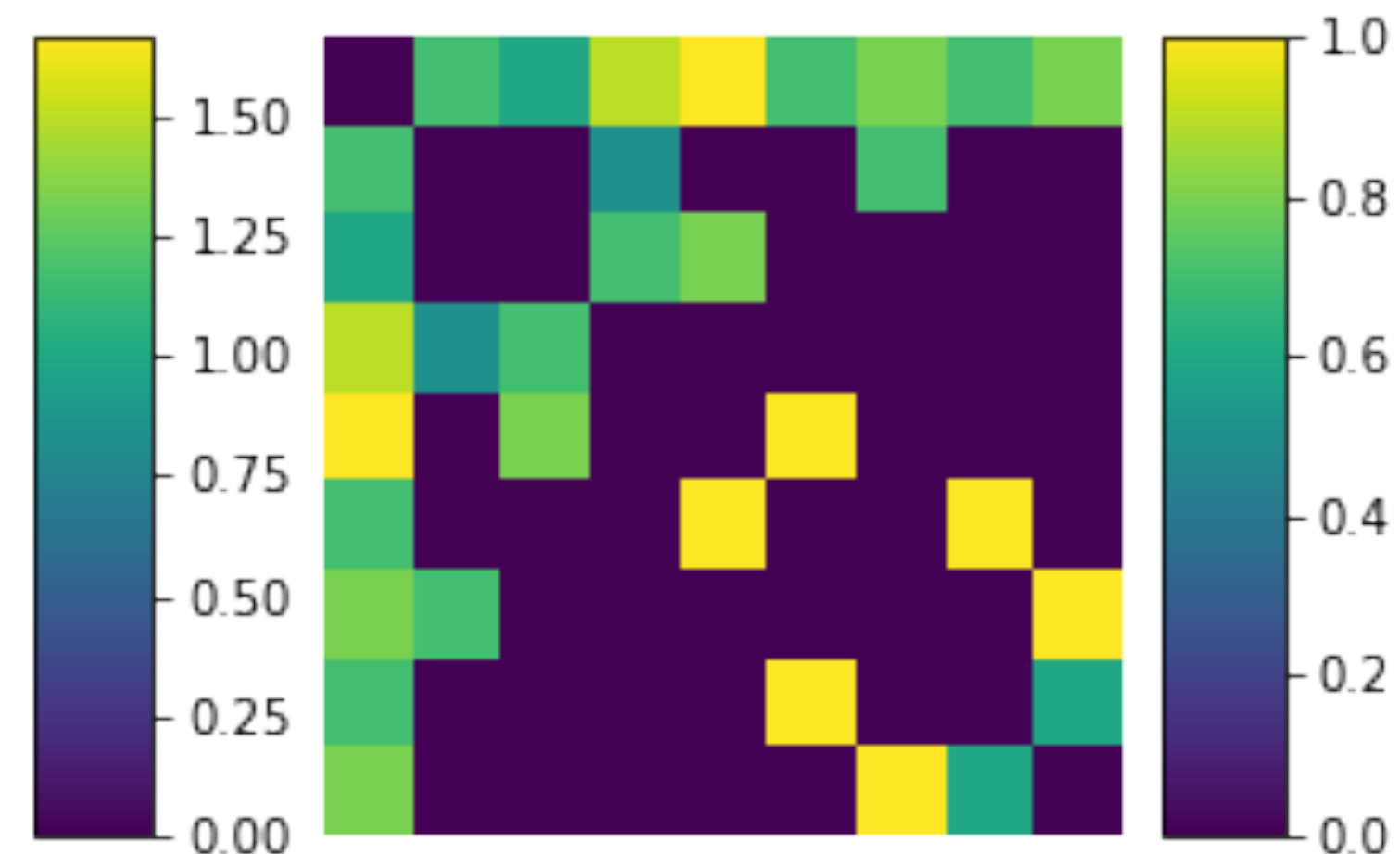

Ants in action

$$p_{ij} = \frac{w_{ij}^\alpha \tau_{ij}^\beta}{\sum_{\langle i,k \rangle} w_{ik}^\alpha \tau_{ik}^\beta} \text{ with } 0 < \alpha < 1 \text{ and } \beta \geq 1$$

$$\tau_{ij} |_{t=0} = 1$$

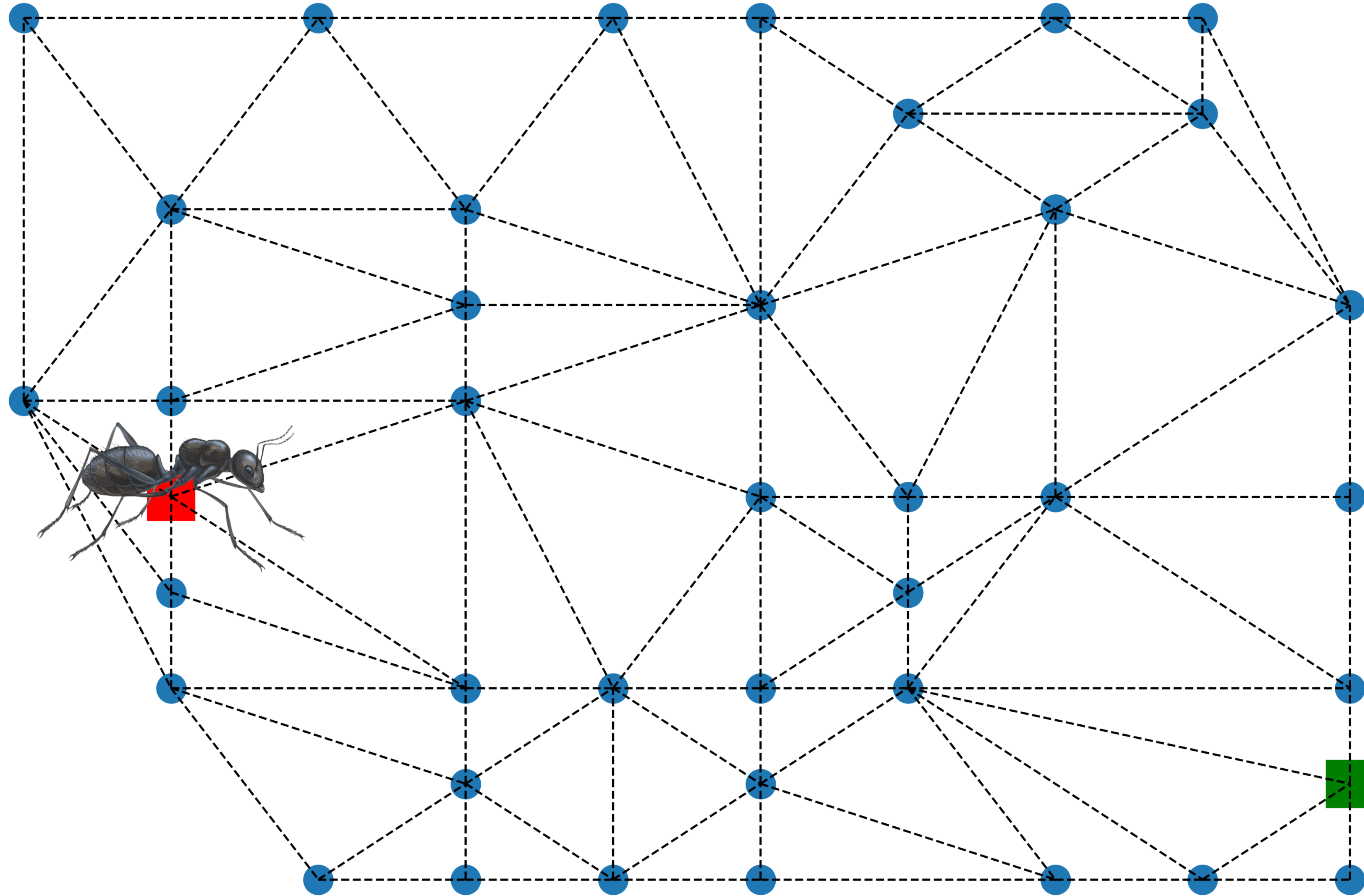

Iteration = 0

Ants in action

$$p_{ij} = \frac{w_{ij}^\alpha \tau_{ij}^\beta}{\sum_{\langle i,k \rangle} w_{ik}^\alpha \tau_{ik}^\beta} \text{ with } 0 < \alpha < 1 \text{ and } \beta \geq 1$$

$$\tau_{ij} |_{t=0} = 1$$

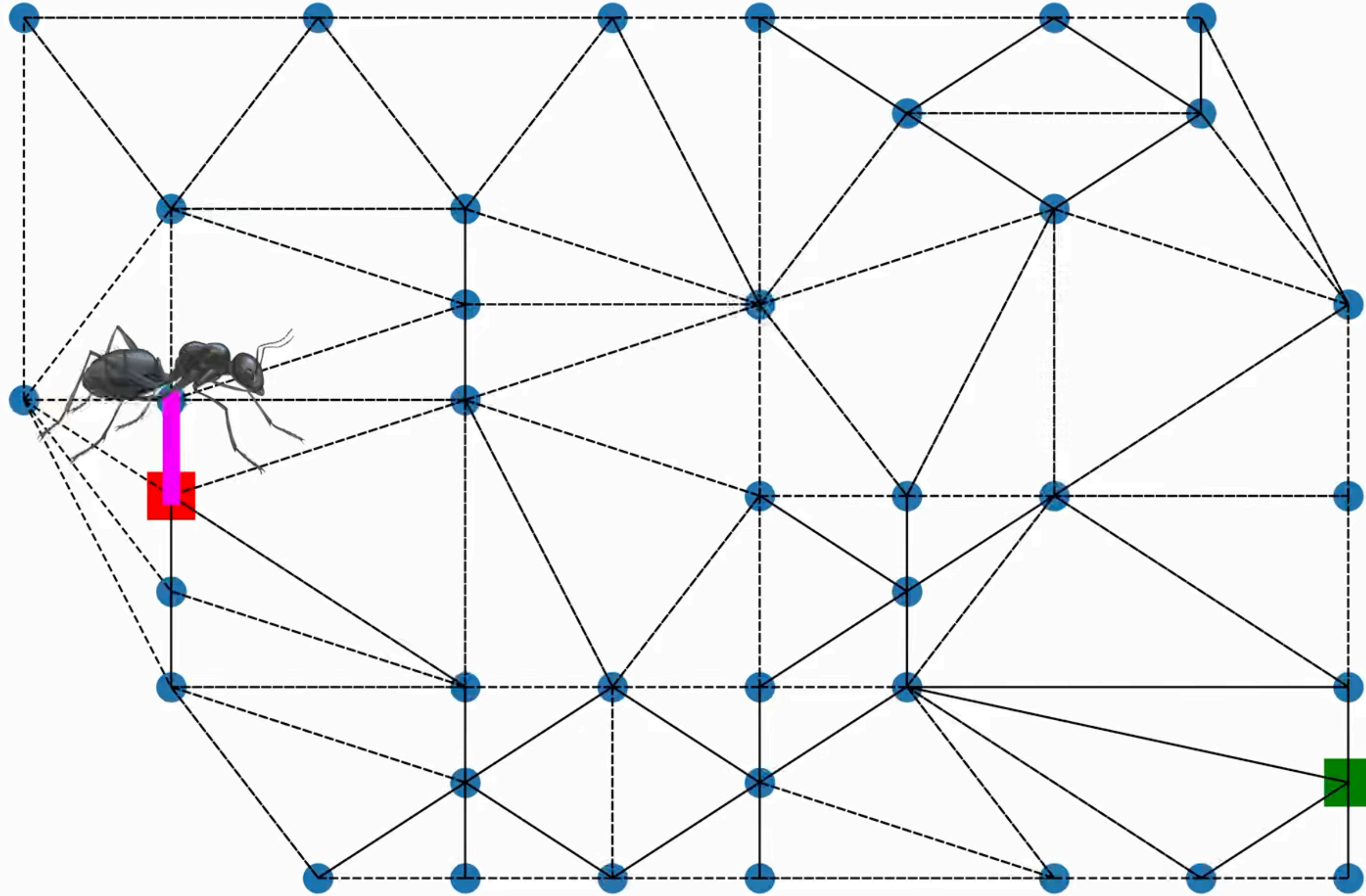

Iteration = 0

Ants in action

$$\tau_{ij} = (1 - \rho)\tau_{ij} + \sum_{n \in ij} \Delta \tau_{ij,n}$$

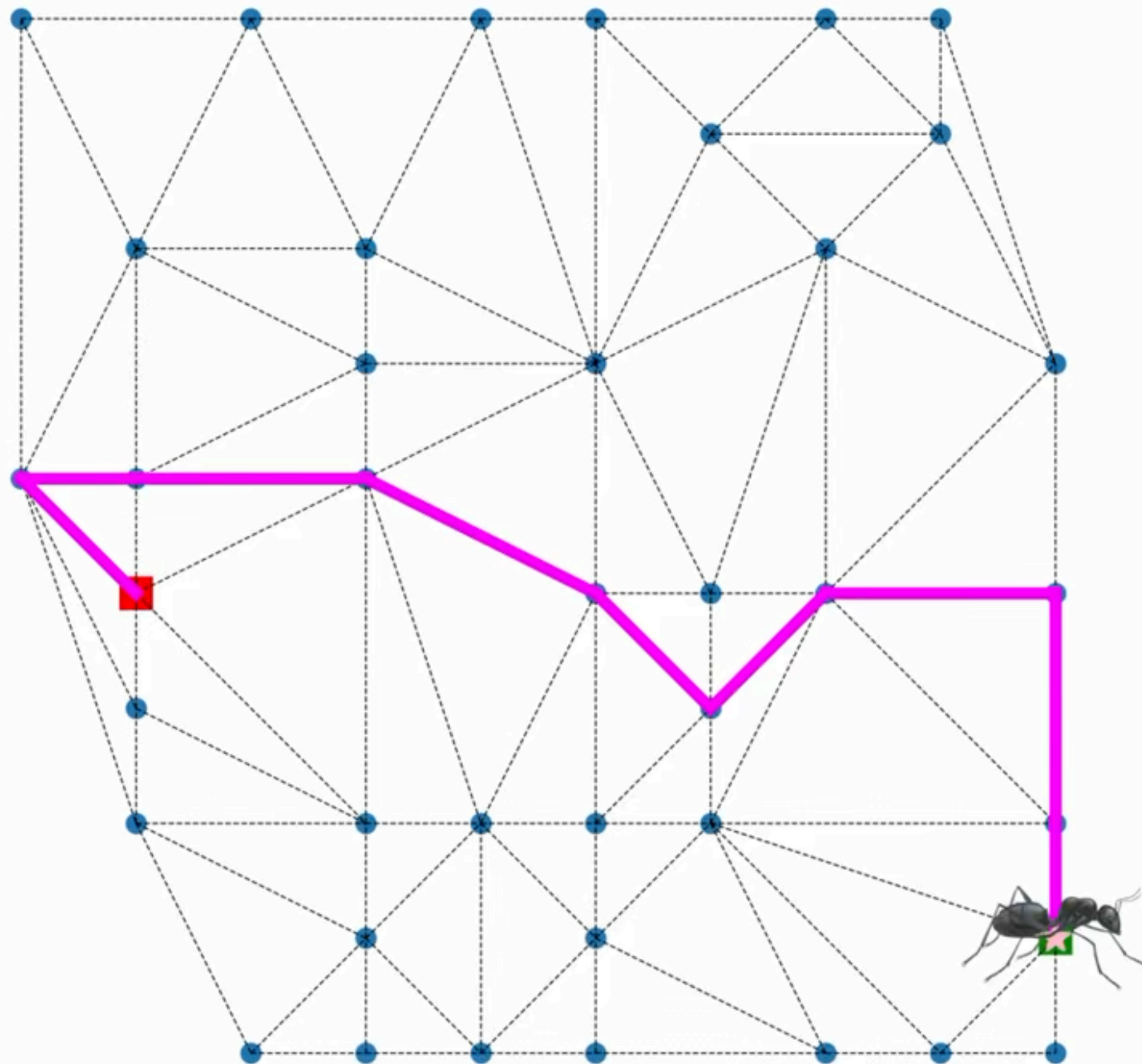

Pheromones

Iteration 0

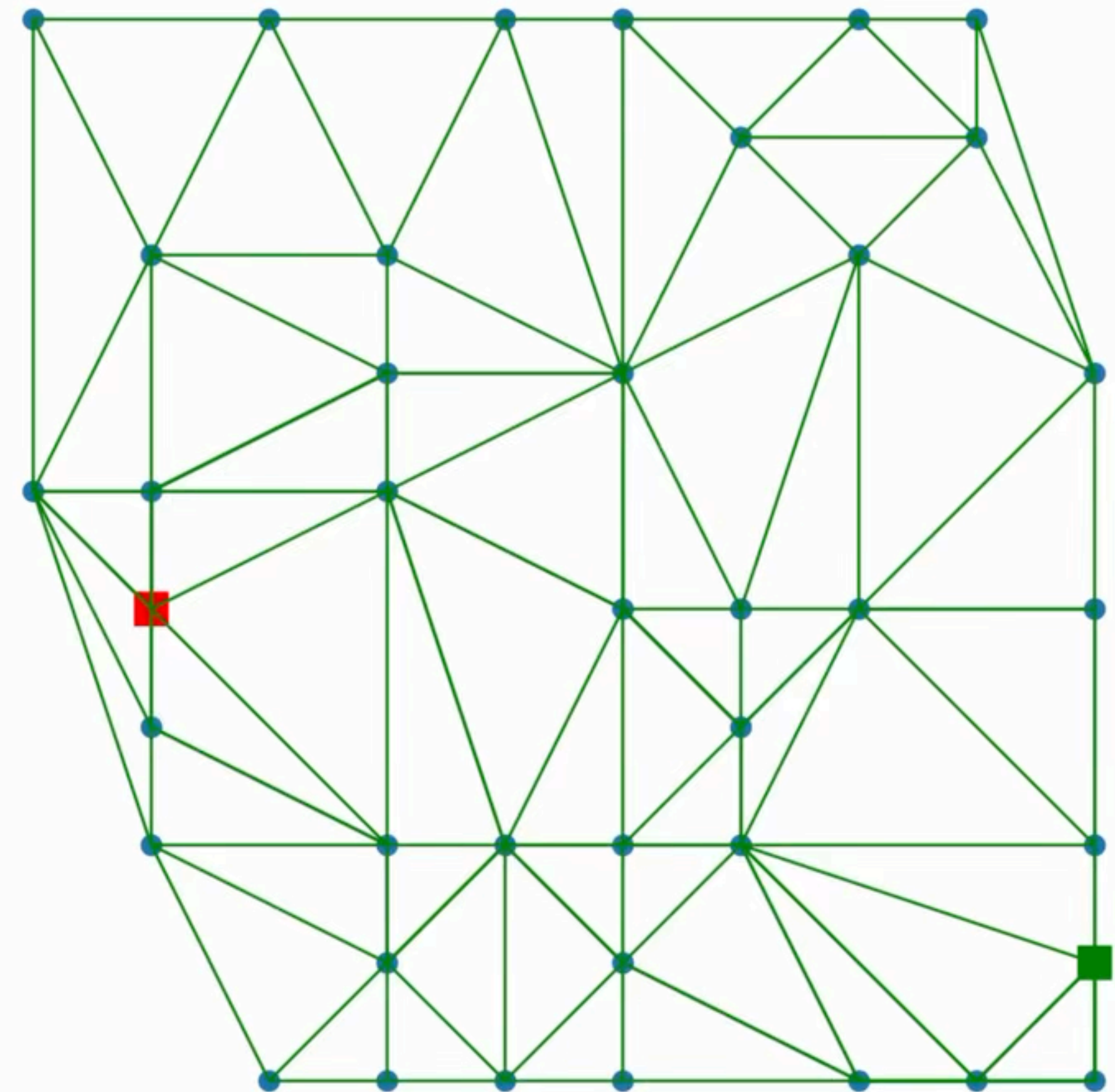

$$\tau_{ij} |_{t=0} = 1$$